

論文 / 著書情報  
Article / Book Information

Title	A Systematic Approach to Manga Case Method
Authors	Satoshi Takahashi, Toru B. Takahashi, Akiko Orita, Atsushi Yoshikawa, Takao Terano
Citation	Proceedings of the 23rd International Conference on Computers in Education. China: Asia-Pacific Society for Computers in Education
Pub. date	2015, 11

# A Systematic Approach to Manga Case Method

Satoshi Takahashi<sup>a\*</sup>, Toru B. Takahashi<sup>b</sup>, Akiko Orita<sup>c</sup>,  
Atsushi Yoshikawa<sup>a</sup> & Takao Terano<sup>a</sup>

<sup>a</sup>*Intelligence and Systems Science, Tokyo Institute of Technology, Kanagawa, Japan*

<sup>b</sup>*Department of Management Science, Tokyo University of Science, Tokyo, Japan*

<sup>c</sup>*The College of Human and Environmental Studies, Kanto Gakuin University, Tokyo, Japan*

\*[takahashi.s.bh@m.titech.ac.jp](mailto:takahashi.s.bh@m.titech.ac.jp)

**Abstract:** The authors conducted an experiment regarding how best to construct and facilitate the manga case method (i.e. MCM), with the aim of demonstrating the impact various instructional factors made on student learning outcomes. MCM is a group learning method that the authors have developed. The experiment was conducted twice, with a total number of 51 test participants. In the experiment, the test participants would be asked, “Which panel you had focused on, and why,” before and after the study session, from which we measured the learning outcomes. Changes were made to the experiment conditions to understand the relationship between the learning outcomes and the factors. The following results were obtained from the learning outcomes in this paper. There were two important points to note in regards to the factor the combination of participants: (a) combining participants that focused on the same panels led to the same level of understanding throughout the group, and (b) combining participants that focused on panels of a significantly different nature led to the participants coming into contact with focus points they hadn’t thought of. Given that these two points contradict each other, it leads one to consider where an acceptable point of balance lies between the two.

**Keywords:** Manga Case Method; Facilitation system; Group learning; Comic; Cartoon

## 1. Introduction

In recent years, teaching methods that focus on the use of knowledge and learning to retain that knowledge have come to be considered important (Barnes, Roland and Hansen, 1994; Wood, 2003). Meanwhile, we have been developing the manga case method (i.e. MCM): a teaching method that teaches participants to apply their knowledge (Yoshikawa, 2007). MCM can be defined as case method materials in a comic book form. A significant feature of MCM is that a variety of problem-related information is expressed through manga and presented in a natural form. The purpose of MCM is to make participants study the “focus points” to locate certain information.

Previous research has shown that learning outcomes from MCM rely heavily on factors like the pre-existing knowledge of the participants and the combination of participants in a group (Yoshikawa, 2007). For example, MCM teaching of decision-making in startups has little effect on participants without any work experience in private companies. Furthermore, group learning when the participants all have the same levels of experience and knowledge is ineffective in helping them encounter new focus points. As a result of this, we have been conducting our research with the aim of constructing a facilitation system for MCM. The facilitation system is used to draw up proposals for suitable MCMs and group compositions for combinations of participants. This function makes effective and predictable manga case method learning a reality. With regards to the construction of this facilitation system, this paper aims to demonstrate the impact of certain factors requiring consideration in the facilitation system on the learning outcomes of those factors.

This paper is divided into five sections: in Section Two, we talk about the factors involved in the facilitation system of the manga case method; in Section Three, we note our experiment method and results; in Section Four, we discuss our observations from the experiment; and finally, in Section Five, we make our conclusion.

## 2. MCM facilitation systems

In this paper, we discuss the construction of facilitation systems to help create an efficient MCM education. A variety of factors influence learning outcomes in the group learning method (which includes MCM). Therefore, when constructing facilitation systems, it is necessary to carefully consider and investigate the factors that affect MCM learning.

Let us look at the prospective constituent elements that are necessary in a facilitation system. Previous research into group learning has demonstrated the impact of the number of participants in a group as well as the way the group is divided by number and assortment of participants on learning outcomes (Johnson, 1984) ((1) the combination of participants, (2) the size of the group, (3) the total number of participants). Furthermore, another important point to consider is whether it is necessary when hosting study sessions for educational institutions and companies to concentrate it all into one day or, if it would be more advantageous to split the schedule across several days ((4) the survey schedule). Yet another important consideration is the extent to which the content of the teaching materials should be made interesting and comprehensible to actively engage the participants in learning ((5) the student's interest in and comprehension of the teaching materials).

## 3. Experiment methods and results

In this paper, we conducted our experiment with the aim of demonstrating the impact various instructional factors made on student learning outcomes. To do this we held group study sessions using MCM teaching materials with a total number of 51 test participants. We also analyzed and compared the “focus points” of test participants before and after the study sessions. We measured the “focus points” of the test participants by asking them “which panel you had focused on, and why,” from the MCM teaching materials (Hotta, Koshiyama, Yamada, Yoshikawa and Terano, 2010; Takahashi, Takahashi, Yoshikawa and Terano, 2015).

We changed the test participants and experiment conditions, as well as conducted the experiment twice to investigate the five factors in our experiment. The changes made to experiment conditions are shown in Table 1. First, in regards to (1) the combination of participants, we selected the participants to combine at random and studied the “focus points” they chose after the experiment. For (2) the size of the group and (3) the total number of participants, we altered the experiment: in the Experiment One there were three groups with three participants in each, while in Experiment Two there were six groups, with five to seven participants in each. For (4) the survey schedule, we conducted Experiment One within the space of a day, while Experiment Two took place over three days. In regards to (5) the student's interest in and comprehension of the teaching material, in Experiment One, group discussions were held at the beginning about the essential points of the teaching materials to engage the student's interest in and comprehension of the teaching materials.

The experiment used “Yamato Aoi” as its MCM teaching material. “Yamato Aoi” is an MCM teaching material; it is about advantages and risk of social media for an IT company.

The exercises implemented in this experiment were Questions 1-7. Questions 1-4 were exercises to categorize the information taken from the MCM teaching materials. Questions 5-7 were then exercises in decision-making, where the student would use the categorized information. The MCM teaching material was distributed a week before the experiment and questions allowed until the day of the experiment to reduce the length of time the experiment took.

There were tests before and after Questions 3 and 4 to work out the “focus points” the participants had reached through the group study session as pretest and posttest. Questions 3 and 4 asked “what panel was the basis of your judgments?” and “what was the reasoning behind it?” to measure the student's “focus points” and to understand what the student was looking at and thinking about.

Experiment One was conducted as a free workshop. In this experiment, the participants were nine university students (Test Participants A-I) majoring in industrial engineering. The experiment was carried out in a group-learning format, where each of the three groups had three participants. Figure 2 (a), (b), and (c) are respectively examples of the way the experiment took place, answering Questions 3 and 4, and the results of the group exercise for Question 7.

When we verified the answers from Experiment One, we found inadequate responses in parts of the experiment. These inadequate responses were found in Questions 3 and 4 of Test Subject G's posttest, in Questions 3 and 4 of Student H's posttest, in Question 4 of Student I's pretest and Questions 3 and 4

of their posttest. The inadequate responses were corrected within a week of finishing the experiment. In the end, we obtained 126 identified focus points in the pretest, and 141 results in the posttest.

Experiment Two was conducted as part of the Information Literacy class. In this experiment, the test participants were university students majoring in international communications. The experiment was split across three days. There were 35 participants on the first day, 42 on the second, and 42 on the third. The test participants were split into eight groups and the experiment was conducted in a group-learning format. The same MCM teaching materials and exercises were used as in the first experiment.

In the results of Experiment Two, there were 17 responses to the pretest for Questions 3 and 4, and 42 responses to the posttest for Questions 3 and 4. Because the pretest was an advance exercise, participants forgot to do it, resulting in the low number of responses. We obtained 192 individual pretest “focus points,” and 638 in the posttest. The only group where results were obtained from all members was Group IV, which was formed from Test Participants J-O.

**Table 1: Experiment condition.**

Factor	Experiment One	Experiment Two
(1) Combination of participants	Random combinations	Random combinations
(2) Size of the group	3 participants(Group I ~ III)	5-7 participants(Group IV ~ XI)
(3) Total number of participants	9 participants(A ~ O)	42 participants (J ~ O and 36)
(4) Survey schedule	All in one day(4 hours 45 min)	Split across three days (1 hours 30 min x 3)
(5) Student’s interest in and comprehension of the teaching material	Initial group discussion about the essential points of the teaching material, to engage the student’s interest and comprehension.	No initial group discussion

## 4. Observations

### 4.1 Acquisition process of focus points

In this section, we observe the acquisition process of participants’ “focus points.” First, we compared the pretest and posttest results of the respective participants, and identify newly given responses in the posttest as “acquired focus points.” We discovered that by comparing these “acquired focus points” with the responses of others and with the outcomes of the group exercises, we could divide the results into three categories. Our categorization method involved the following three elements. First, if the “acquired focus points” matched with either the pretests of other members of the group or outcomes from the group exercises, they would be categorized into Group 1—“exchange of focus points within the group.” This is because it was assumed that the student had learned about the focus points of other group members through the group discussions. Second, if the “acquired focus points” matched with the outcomes from a different group, they would be categorized into Group 2—“exchange of focus points with other groups.” This is because it was assumed that the group would have seen the presentations of another group or asked it questions, and in doing so would have learned about the other group’s focus points. Last, any “acquired focus points” that didn’t fit into either of the two preceding categories would be placed into Group 3—“emergence of focus points.” This is because it was assumed that these new, individual focus points had emerged through group discussions. We give examples of each category below.

Figure 2 shows the number of “acquired focus points” that were collated. The diagram shows that “exchanges of focus points with other groups” were relatively few, and that the majority of exchanges were either “exchanges of focus points within the group” or “emergence of new focus points.” Furthermore, comparing Experiments One and Two demonstrates that three different types of learning were occurring in both experiments. In addition, more “exchanges of focus points with other groups” and “exchanges of focus points within the group” occurred in Experiment Two than Experiment One. We imagine this to be because there were a greater total number of participants and larger groups in Experiment Two, meaning that there were simply more occasions on which a student would come into contact with the “focus points” of another student.

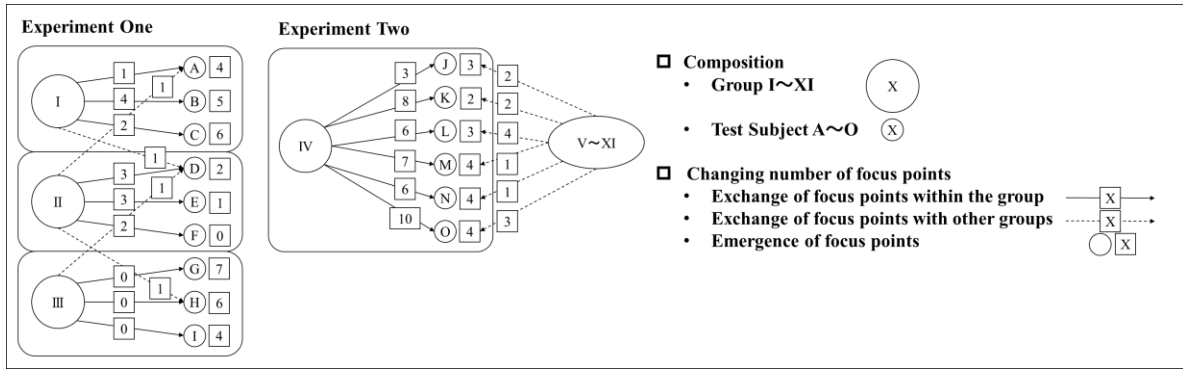

Figure 2. Changing numbers of focus points.

#### 4.2 Student combinations and learning outcomes

In this section, we observe the impact of combinations of participants in groups on learning outcomes. First, Figure 3 (a) shows the rate of concordance of panel selection by participants in their pretests for each group. To find the rate of concordance of panel selection, we took the total number of panels chosen by the members of a group as the denominator, and the number of panels selected by other members of the group as the numerator. An example of our calculations for the rate of concordance is shown in Figure 3 (b). Figure 3 (c) shows “the rate of concordance of panel selection,” “the number of exchanges of focus points within a group by each person” for each group, as well as a graph of “the number of acquisitions of new focus points by each person.”

Figure 3 (c) shows that when the value of “the rate of concordance of panel selection” decreases, “exchanges of focus points within the group by each person” does not occur. The fact that the rate of concordance for mutual focus points is low strongly suggests that it is difficult to reach a level of common understanding in a group. In other words, because no level of mutual understanding was obtained, the conversations did not converge and it was impossible to exchange mutual points of view. Meanwhile, no correlation could be found between “the rate of concordance of panel selection” and “the number of acquisitions of new focus points by each person.” In other words, although there were gaps in the group’s level of mutual understanding, the individual still discovered new focus points.

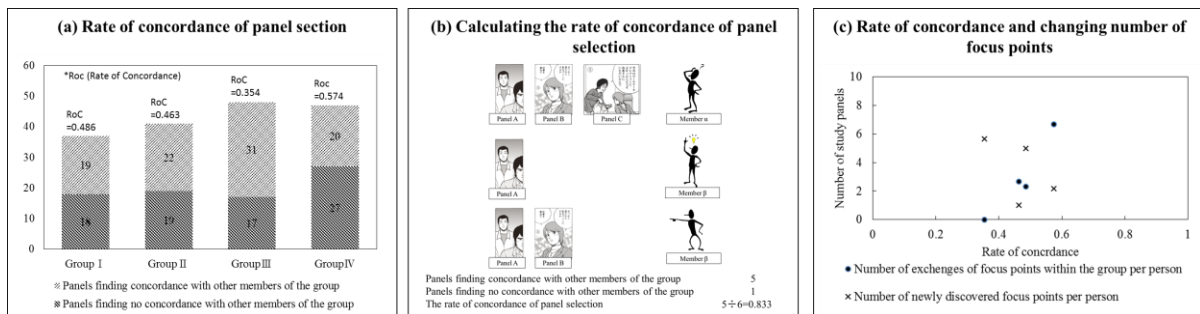

Figure 3. (a) Rate of concordance of panel section; (b) Calculating the rate of concordance of panel section; (c) Rate of concordance and changing number of focus points.

#### 4.3 Impact of participants’ initially studied focus points on learning outcomes

In this section, we observe the relationship between focus points that the test participants identified beforehand and the focus points that they acquired through the learning process. First, the relationship between the focus points that the test participants identified beforehand (pretest) and the focus points that they acquired through the learning process (posttest) was analyzed using the following four-step process (Figure 5). Step One: calculating the similarity ratio (distance matrix) of mutual focus points from the results of all the test participants’ pretests. Step Two: using the distance matrix to calculate the distance between each focus point from the results of the pretests of respective test participants. Step Three: using the calculated distance matrix to build a ranking table of distances between the focus points in each of the pretests. Step Four: plotting the results from the pretests and posttests on the ranking table. Gray cells represent the pretests and black cells represent the posttests.

Figure 6 shows the graphs to represent the number of posttest focus points for each ranking of the plotted table built from the actual results of the experiments. It is clear that as the rankings fall lower the number of acquired focus points in the posttest increase in both Experiments One and Two.

It would initially seem obvious that focus points from the pretest and focus points with a close distance matrix should be easier to learn about. However, we actually found that focus points with the highest degrees of deviation based on the matrix would be most actively engaged with. We think this could be because participants were able to come into contact with focus points they had not considered during the group discussions and that left a strong impression, leading them to take the lesson to heart.

We can guess from these results that participants were most effectively made to learn about focus points when they were placed as part of the group divisions with other group members with whom they had mutually distant focus points.

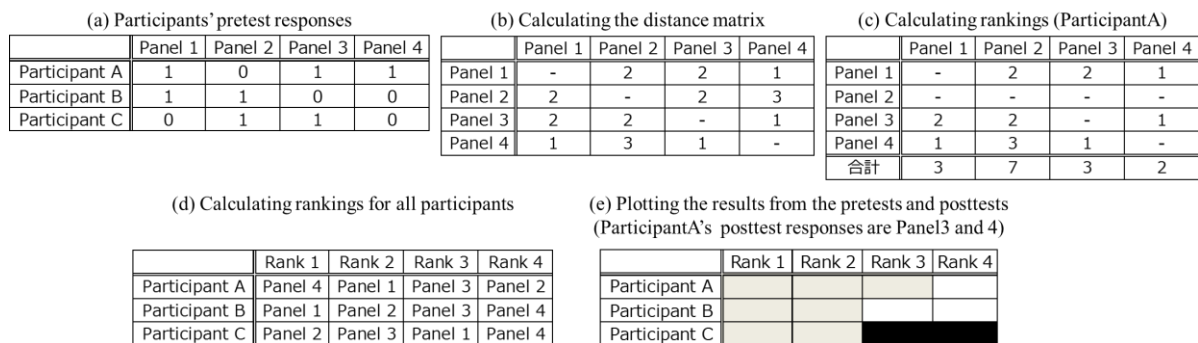

Figure 5. (a) Participants' pretest responses; (b) Calculating the distance matrix; (c) Calculating rankings (Participant A); (d) Calculating rankings for all participants; (e) Plotting the results from the pretests and posttests.

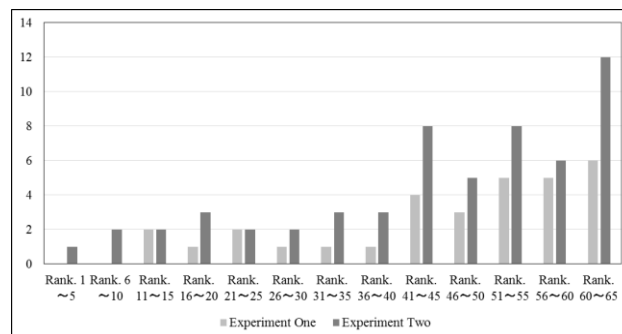

Figure 6. Aggregate results of posttest for each ranking.

#### 4.4 Summary

We found no particular, clearly obvious differences in regards to (4) the survey schedule and (5) the student's interest in and comprehension of the teaching materials during this experiment. MCM teaching materials differ from normal text-based teaching materials, and easily engage the student's interest and place them immediately into the center of the story. Furthermore, during the discussions, it was easy for the participants to reach a common level of understanding by pointing to the manga panel to show what they were talking about. We think that because of these particular features, a sufficient level of learning outcomes can be obtained, even if the schedule is squeeze into one day, and regardless of if advance exercises are given to the participants to engage their interest or not. The above observations are recorded in Table 2.

Table 2: Investigation results for each factor.

Factor	Content
--------	---------

---

(1) Combination of participants	(1) When “the rate of concordance of panels” within a group is higher than a certain point, the group will be able to come to a mutual level of common understanding.  (2) Placing a student in a group with members with focus points far different to their pre-existing focus points allows them to come into contact with new focus points.
(2) Size of the group	Having six participants in a group led to more exchanges of focus points within a group than when there were three. However, we believe an upper limit exists.
(3) Total number of participants	Having 42 participants in a group led to more exchanges of focus points with other groups than when there were 9. However, we believe an upper limit exists.
(4) Survey schedule	No obvious difference seen with regards to learning outcomes.
(5) Student’s interest in and comprehension of teaching material	No obvious difference seen with regards to learning outcomes

---

## 5. Conclusion

We conducted an experiment in relation to the construction of facilitation systems of MCM, with the aim of demonstrating the impact of various instructional factors made on student learning outcomes. In the experiment, we used the question “which panel did you focus on, and why,” to measure changes in the participants’ focus points. The results from the experiment suggested, in regards to the combination of participants, that the two following factors should be carefully considered when dividing a group, using the results of the pretests. Because these two points contradict each other, we believe that an appropriate point of balance must exist between the two.

(a) Combining participants that focused on the same panels led to the same level of understanding throughout the group.

(b) Combining participants that focused on panels of a significantly different nature led to the participants coming into contact with focus points they had not thought of.

In the future, we plan to use these findings to build an MCM facilitation system in order to conduct an experiment to prove our discoveries.

## Acknowledgements

This work was supported by JSPS KAKENHI Grant Numbers 26750088, 23501059, 25240048.

We thank Professor Haruki Yoshikatsu of Ferris University, Japan for their cooperation in conducting the experiment for this research.

This work was supported by foundation for the Fusion Of Science and Technology.

## References

- Barnes, L. B., Roland C. C., Hansen, A. J. (1994). Teaching and the Case Method. Text, Cases, and Readings. 3rd ed. Boston: Harvard Business School Press.
- Wood, D. F. (2003). Problem based learning. *Bmj*. (doi: <http://dx.doi.org/10.1136/bmj.326.7384.328>)
- Yoshikawa A. (2007). Situated Intelligence Training Training Method to Utilize the Knowledge : Situated Intelligence Training. *System/Control/Information : ISCIE*, 51(2), 102-108. (in Japanese)
- Hotta D, Koshiyama O, Yamada T, Yoshikawa A, Yamamoto H, Terano T. (2010). Recommendation method to give other learner’s viewpoints in a Manga Textbook. *Japan Society for Science Educations*, 34(2), pp. 154-166,
- Takahashi S, Takahashi B. T, Yoshikawa A, Terano T. (2015). If Experience is Worth, How Experts Behave in a MANGA Case. Proc. The Seventh International Conference on Information, Process, and Knowledge Management (eKnow 2015) pp. 159-165, February 22.
- Johnson, D. W. (1984). Circles of learning. Cooperation in the classroom. Association for Supervision and Curriculum Development, 225 North Washington St., Alexandria, VA 22314.