

論文 / 著書情報  
Article / Book Information

題目(和文)	
Title(English)	Finite N Corrections to the Superconformal Index in AdS/CFT Correspondence
著者(和文)	荒井玲於奈
Author(English)	Reona Arai
出典(和文)	学位:博士(理学), 学位授与機関:東京工業大学, 報告番号:甲第11871号, 授与年月日:2021年3月26日, 学位の種別:課程博士, 審査員:今村 洋介,伊藤 克司,慈道 大介,須山 輝明,山口 昌英
Citation(English)	Degree:Doctor (Science), Conferring organization: Tokyo Institute of Technology, Report number:甲第11871号, Conferred date:2021/3/26, Degree Type:Course doctor, Examiner:,,,,
学位種別(和文)	博士論文
Type(English)	Doctoral Thesis

Doctoral Thesis

**Finite  $N$  Corrections  
to the Superconformal Index  
in AdS/CFT Correspondence**

---

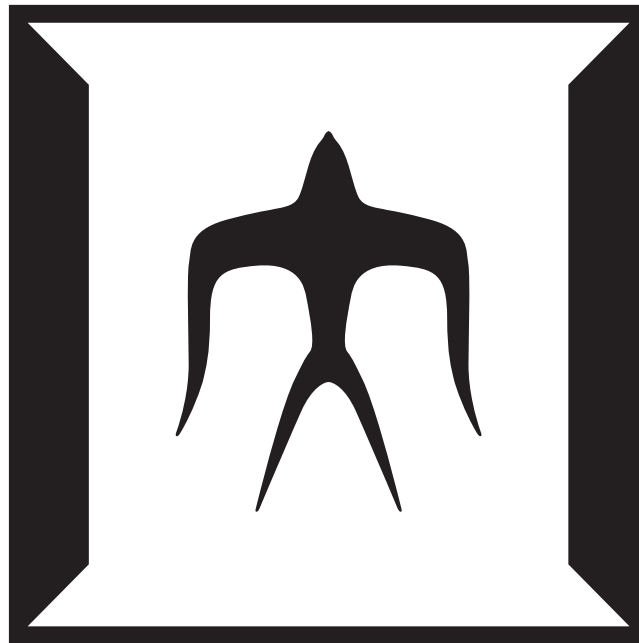

Reona Arai

*Department of Physics, Tokyo Institute of Technology  
Tokyo, 152-8551, Japan*

*February, 2021*



# Abstract

In this thesis, we propose a new calculation method of the superconformal index by using the Anti-de Sitter (AdS)/Conformal Field Theory (CFT) correspondence.

AdS/CFT is a correspondence between a four-dimensional conformal field theory (CFT) and type IIB string theory on  $AdS_5 \times \mathcal{M}_5$  (AdS), where  $\mathcal{M}_5$  is a five-dimensional compact manifold. This is the strong/weak duality, and one can use AdS/CFT to study the strongly coupled field theories from the theory on the AdS side. There are many AdS/CFTs depending on the compact manifold  $\mathcal{M}_5$ . The simplest example is  $\mathcal{M}_5 = S^5$ , and the corresponding CFT is  $\mathcal{N} = 4$   $U(N)$  supersymmetric Yang-Mills (SYM) theory. There are also AdS/CFTs in which the Lagrangian on the CFT side is not known. The interesting example is AdS/CFT between a  $\mathbb{Z}_k$  S-fold theory and type IIB string theory on  $AdS_5 \times S^5/\mathbb{Z}_k$ , where the S-fold theory is an  $\mathcal{N} = 3$  superconformal field theory (SCFT) and always strongly coupled. In this case, AdS/CFT is a significant tool to study the S-fold theories. To understand strongly coupled field theories, the study of theories for which the Lagrangian is not known is quite important.

It is possible to understand AdS/CFT from D3-branes in type IIB string theory, where the D3-brane is a 3+1-dimensional object. A rank  $N$  CFT is realized on the worldvolume of  $N$  D3-branes, while D3-branes produce the AdS geometry. This is the origin of AdS/CFT. In the large  $N$  limit, the AdS side is well described by classical gravity, and there are many applications to the analysis of strongly coupled theories, even for the theories for which the Lagrangian is not known. On the other hand, if  $N$  is finite, it is believed that the theory on the AdS side is described by quantum gravity. Since no one knows quantum gravity, people think that it is difficult to calculate the physical quantities on the CFT side from the AdS side when  $N$  is finite.

However, it may be possible to calculate the superconformal index by using AdS/CFT due to the simplification by the supersymmetry even though  $N$  is finite. The superconformal index has the information of the BPS operator spectrum of a given SCFT and is independent of the coupling constant. Thus, if we calculate the superconformal index for an SCFT, one can immediately obtain the non-trivial information of the SCFT even though the Lagrangian is not known. In fact, the calculation method of the superconformal index on the AdS side in the large  $N$  limit is already known, and the application to S-fold theories has also been performed by using AdS/CFT. Furthermore, the candidates that contribute to the superconformal index on the AdS side in the finite  $N$  region are known: the D3-branes wrapped on three-cycles in the compact manifold  $\mathcal{M}_5$ .

Inspired by these previous researches, we develop the calculation method of the superconformal index on the AdS side when  $N$  is finite. To achieve this purpose, we adopt the following strategy. First, we use the well-known AdS/CFT: the correspondence between  $\mathcal{N} = 4$   $U(N)$  SYM and type IIB string theory on  $AdS_5 \times S^5$ . In this case, the superconformal index is calculable using the Lagrangian on the CFT side. The results then provide us a hint to search for the calculation method of the superconformal index on the AdS side in the finite  $N$  region. Concretely, we analyze the single wrapped D3-branes and compare the results with the CFT results. Then, we propose the calculation method of the superconformal index on the AdS side in the finite  $N$  region. We see that our results agree with the CFT results up to contributions from the multiple wrapped D3-branes. Second, we apply our method to S-fold theories. Then, we can predict the superconformal index of the finite rank S-fold theories from the AdS side. Since it is expected that the rank one and two S-fold theories are equivalent to  $\mathcal{N} = 4$  SYM, we can carry out the consistency check. Besides this check, recently, the superconformal index of the rank three  $\mathbb{Z}_3$  S-fold theory was calculated using the renormalization group flow, and we can confirm the correctness of our method for this case. All the results given in this thesis are consistent with the known facts.

# Acknowledgment

First of all, the author expresses his gratitude to his supervisor Yosuke Imamura for his patient and kind guidance throughout his five-year career in the particle theory group in Tokyo Institute of Technology. The author also gives his thanks to the faculty of the particle theory laboratory in Tokyo Institute of Technology, Katsushi Ito and Yoshiyuki Watabiki. The author appreciates his collaborators for discussions and their guidance, Shota Fujiwara, Yosuke Imamura, Tatsuya Mori, and Daisuke Yokoyama. He also thanks to the following people for stimulating discussions, Testuji Kimura, Yoshishige Kobayashi, Shoichi Kanno, Masaya Yata, Yugo Abe, Naoto Kan, Yusuke Kanayama, Hirotaka Kato, Hongfei Shu, Takafumi Okubo, Saki Koizumi, Yusuke Nagatsuka, Takashi Hagiwara, Kohei Fujikura, Kensuke Akita, Stephan Hübsch, Kohei Kuroda, Takayasu Kondo, Shota Fujiwara, Tatsuya Mori, Yota Endo, Keita Imaizumi, Rei Masuda, Keisuke Sawaizumi, Kodai Kitahara, Shingo Horikawa, Shuichi Murayama, Sumiya Umezu, Mingshuo Zhu, Ibuki Hashimoto, Jingjing Yang and all the members of the fundamental physics group. The author thanks all the universities and institutes that have provided the nice research environments, especially thanks to the Center for Field Theory and Particle Physics in Fudan University, the particle theory group in Rikkyo University, Komaba particle theory group in University of Tokyo, Riken iTHEMS, OCU research group for mathematical physics in Osaka City University, and the particle theory group in Saitama University for inviting the author as a speaker of a seminar and stimulating discussions with the members of those universities and institutes.

The author appreciates the financial support from the Sasakawa Scientific Research Grant of The Japan Science Society.

Finally, the author thanks his parents and sister for their warm support in all aspects.



# Contents

<b>Chapter 1</b>	<b>Introduction</b>	<b>9</b>
1.1	Partition function . . . . .	13
1.2	Witten index . . . . .	16
1.3	Localization . . . . .	18
1.4	Superconformal field theory . . . . .	20
	1.4.1 Conformal symmetry . . . . .	20
	1.4.2 Superconformal symmetry . . . . .	23
	1.4.3 Deformation of CFTs . . . . .	26
	1.4.4 Theories for which the Lagrangian is unknown . . . . .	28
1.5	Superconformal index . . . . .	29
	1.5.1 Chiral ring . . . . .	30
	1.5.2 Superconformal index for Lagrangian theories . . . . .	32
1.6	BPS partition function . . . . .	34
<b>Chapter 2</b>	<b>AdS/CFT Correspondence</b>	<b>37</b>
2.1	Four-dimensional $\mathcal{N} = 4$ supersymmetric Yang-Mills theory . . . . .	37
	2.1.1 $\mathcal{N} = 1, 2$ decomposition . . . . .	41
	2.1.2 Coulomb branch and Higgs branch . . . . .	42
	2.1.3 BPS partition function . . . . .	44
	2.1.4 Superconformal index . . . . .	49
2.2	Type IIB string theory . . . . .	54
	2.2.1 Closed strings . . . . .	55
	2.2.2 Open strings . . . . .	56
	2.2.3 D-branes . . . . .	57
	2.2.4 Type IIB supergravity . . . . .	61
2.3	The correspondence . . . . .	62
	2.3.1 D3-brane picture . . . . .	64
	2.3.2 Black 3-brane solution . . . . .	65
2.4	Agreement of the index in the large $N$ limit . . . . .	66
	2.4.1 BPS partition function . . . . .	66
	2.4.2 Superconformal index . . . . .	68
<b>Chapter 3</b>	<b>Finite <math>N</math> Corrections to the Superconformal Index</b>	<b>73</b>

3.1	BPS partition function . . . . .	75
3.2	Superconformal index . . . . .	83
3.2.1	Supersymmetry on wrapped D3-branes . . . . .	83
3.2.2	Superconformal index of wrapped D3-brane . . . . .	85
3.2.3	Comparison with the CFT side . . . . .	88
<b>Chapter 4</b>	<b>Four-Dimensional S-fold Theories</b>	<b>91</b>
4.1	$\mathcal{N} = 4$ orientifold theory . . . . .	91
4.1.1	AdS/CFT correspondence in the orientifold background . . . . .	92
4.1.2	BPS partition function . . . . .	94
4.1.3	Superconformal index . . . . .	97
4.2	S-fold theories . . . . .	99
4.2.1	AdS/CFT correspondence in the S-fold background . . . . .	102
4.2.2	Properties of S-fold theories . . . . .	103
4.3	BPS partition function of S-fold theories . . . . .	106
4.4	Large $N$ limit on the AdS side . . . . .	108
4.4.1	BPS partition function . . . . .	109
4.4.2	Superconformal index . . . . .	109
4.5	Finite $N$ corrections . . . . .	113
4.5.1	BPS partition function . . . . .	113
4.5.2	Superconformal index . . . . .	117
4.6	Consistency check . . . . .	120
4.6.1	Supersymmetry enhancement . . . . .	120
4.6.2	Comparison with Zafrir's result . . . . .	121
<b>Chapter 5</b>	<b>Conclusions and Discussions</b>	<b>123</b>
<b>Appendix A</b>	<b>Conventions and Notations</b>	<b>127</b>
A.1	Spinor convention for four-dimensional theories . . . . .	127
A.2	Notations of group theory . . . . .	129
A.2.1	Dynkin label . . . . .	129
A.2.2	Character formula . . . . .	130
<b>Bibliography</b>		<b>131</b>

# Chapter 1

## Introduction

Quantum field theories (QFT) has been extensively studied in elementary particle physics. In particular, the weak coupling region of QFT is well understood by the perturbation method. On the other hand, it is difficult to analyze the strong coupling region of QFT because the perturbation method is not applicable. Nevertheless, strongly coupled field theories often appear in particle physics. For example, quantum chromodynamics (QCD) is an asymptotically free theory and becomes the strongly coupled theory in the low energy region. One of the quite important problems in QCD is to understand color confinement. So far, no one understands color confinement in an analytical way, even though the lattice QCD suggests that color confinement should occur. To solve the color confinement problem, the understanding of the strongly coupled field theory is essential.

Although the strong coupling region of the realistic QFT is very difficult to analyze, one can learn many things about the strongly coupled physics from the supersymmetric field theories. The supersymmetry is the symmetry between bosonic fields and fermionic fields. This supersymmetry algebra is generated by  $\mathcal{N}$  Lorentz spinor generators. The restriction for the theory is stronger as  $\mathcal{N}$  increases. It is known that  $\mathcal{N}$  is smaller than or equal to four for four-dimensional field theory without gravity.

$\mathcal{N} = 1$  supersymmetric theories are important for phenomenology. Since the restriction of  $\mathcal{N} = 1$  supersymmetry for the theory is relatively weak, one can construct various phenomenological models with  $\mathcal{N} = 1$  supersymmetry. However,  $\mathcal{N} = 1$  supersymmetry is not enough to solve the theory. On the other hand,  $\mathcal{N} = 4$  supersymmetry gives the quite severe constraint to the theory, and it is believed that  $\mathcal{N} = 4$  supersymmetric Yang-Mills (SYM) theory [1, 2] is the only theory having  $\mathcal{N} = 4$  supersymmetry in four-dimension. Therefore, an  $\mathcal{N} = 4$  theory is uniquely specified by the gauge group only. Although this theory cannot be the realistic theory, it is still interesting as a toy model to learn the strongly coupled physics because the quantum corrections to the theory are suppressed due to the boson/fermion cancellation. Furthermore, since the  $\beta$ -function of this theory is zero,  $\mathcal{N} = 4$  SYM also has the conformal symmetry. In total,  $\mathcal{N} = 4$  SYM has the  $\mathcal{N} = 4$  superconformal symmetry.

For  $\mathcal{N} = 2$  supersymmetric theories, the restriction is not so strong. However, it is enough to calculate the low energy effective action, which is obtained by integrating out

the massive modes in the theory. In fact, Seiberg and Witten determined the low energy effective action of  $\mathcal{N} = 2$   $SU(2)$  gauge theory [3, 4] in 1994. They used a certain Riemann surface to obtain the low energy effective action. Such a Riemann surface is called the Seiberg-Witten (SW) curve. The understanding of the non-perturbative effect in the supersymmetric field theory has been greatly progressed by their success. For instance, one can explain the electric charge confinement via the monopole condensation by breaking  $\mathcal{N} = 2$  to  $\mathcal{N} = 1$ .

In addition to the understanding of the non-perturbative effects of QFT, the diversity of QFT is recognized more than before by Seiberg and Witten's analysis. The significant fact is that there are many conformal field theories (CFT) that the construction of the Lagrangian is uncertain. Since it looks like that these theories have no tunable parameters, there is no general procedure that gives the Lagrangian (or, there are few tunable parameters that can help us find the Lagrangian). The famous examples of such theories are Argyres-Douglas (AD) theories [5, 6]. AD theories arise at the superconformal fixed point in which the mutually non-local BPS particles become massless [5–9]. Note that, in principle, the existence of the ultra-violet (UV) Lagrangian that flows to a target theory in the renormalization group (RG) flow is enough to analyze the theory. In fact, the UV Lagrangian that flows to a certain AD theory was discovered by Maruyoshi and Song [10], and some physical quantities were discussed. Although it is quite difficult to analyze theories for which neither the Lagrangian nor UV Lagrangian are known, one may be able to analyze them by using dualities.

A duality is a correspondence between outwardly different but physically equivalent theories. In the duality, it often occurs that a strongly coupled theory corresponds to a weakly coupled theory. In such a situation, the duality enables us to analyze the strongly coupled theory via the dual weakly coupled theory. For example, in Seiberg and Witten's analysis, the electric-magnetic duality, an example of strong/weak duality, plays an important role.

Another significant example of strong/weak duality is the AdS/CFT correspondence proposed by Maldacena [11] in 1997. Roughly speaking, the AdS/CFT correspondence is a correspondence between a  $d$ -dimensional CFT and a  $d + 1$ -dimensional gravity theory on Anti-de Sitter (AdS) spacetime. This correspondence can be understood through the string theory. The string theory is a theory of strings defined on ten-dimensional spacetime, and there are  $p + 1$ -dimensional objects called D $p$ -branes as well as strings. The  $p + 1$ -dimensional field theory is realized on the worldvolume of D $p$ -branes [12], whereas the AdS spacetime is realized near the D-branes [13]. Although this observation is far from the proof of AdS/CFT, it is enough to convince us that AdS/CFT holds.

It is known that the strong coupling region on the CFT side corresponds to the classical gravity on the AdS side. Thus, AdS/CFT provides us a powerful tool to investigate the strong coupling region of QFT. One can construct AdS/CFT that the theory on the CFT side is a QCD-like theory by arranging the D-branes in the string theory. The Sakai-Sugimoto model [14, 15] is known as an example of such the case. One can calculate the

mass of mesons in the Sakai-Sugimoto model, and it is a good example of applications of AdS/CFT to QCD. It is also known that if the rank of CFT (number of D-branes in the string theory setup) is finite, the corresponding gravity theory is quantum gravity. Then it is possible to investigate quantum gravity by using AdS/CFT. However, this fact is an obstacle to study the strongly coupled CFT with the finite rank when we use AdS/CFT.

Physical quantities protected by the supersymmetry may overcome this obstacle due to the simplification by the supersymmetry. Candidates of such quantities are the superconformal index and the BPS partition function [16]. The superconformal index is a kind of partition functions defined in a superconformal field theory (SCFT). It has information regarding the operator spectrum of the theory. Also, the superconformal index does not depend on the coupling constant and is calculable by using the Lagrangian on the CFT side. Once we calculate the superconformal index, we can obtain the non-trivial information of the theory. Thus the calculation of the superconformal index for SCFTs, for which the Lagrangian is not known, is the first goal of the analysis of such SCFTs. Similarly, the BPS partition function also has information about the operator spectrum of the theory. Moreover, the structure of the BPS partition function is much simpler than the superconformal index, and it is useful to speculate the structure of the superconformal index.

In this thesis, we would like to calculate the superconformal index of the finite rank SCFTs, for which the Lagrangian is not known, by using AdS/CFT in the finite  $N$  region, where  $N$  is the rank of a given SCFT. Then, we need to develop the calculation method of the superconformal index on the AdS side when  $N$  is finite. This research also helps to expand the scope of applications of AdS/CFT.

For this purpose, it is useful to consider the simplest AdS/CFT: the correspondence between  $\mathcal{N} = 4$   $U(N)$  SYM and type IIB string theory on  $AdS_5 \times S^5$ . In this case, the Lagrangian on the CFT side is known, and the superconformal index is calculable. The concrete expression of the superconformal index provides us a hint to search for the calculation method of the superconformal index on the AdS side. First, AdS/CFT in the  $N \rightarrow \infty$  limit (large  $N$  limit) is well studied because the corresponding theory on the CFT side is classical gravity. Actually, the superconformal index on the AdS side was calculated as contributions of Kaluza-Klein (KK) modes on  $S^5$ , and the agreement with that on the CFT side was confirmed [16]. Second, when  $N$  is finite, there are new contributions coming from the D3-branes wrapping on three-cycles in  $S^5$  as well as KK modes. The existence of supersymmetric configurations of D3-branes expanded in  $S^5$  was first shown in [17]. The calculation method of the superconformal index for such wrapped D3-branes has not been known so far, and we propose the formula to calculate the contributions of wrapped D3-branes on the AdS side. Based on the formula, we also confirm the agreement of the superconformal index with that on the CFT side up to a certain order of the parameters in the index. A similar analysis of the BPS partition function is also given.

Once we develop the calculation method of the superconformal index on the AdS side

in the finite  $N$  region, we can apply our method to SCFTs for which the Lagrangian is not known. We focus on the S-fold theories as examples of such theories. Namely, we calculate the superconformal index of the S-fold theories as well as the BPS partition function. An S-fold theory is an  $\mathcal{N} = 3$  SCFT and constructed by Garcia-Etxebarria and Regalado [18] in 2015. It is well known that any  $\mathcal{N} = 3$  theories connected with the free theory by tuning the parameters have  $\mathcal{N} = 4$  supersymmetry automatically. So the existence of genuine  $\mathcal{N} = 3$  theories that do not have  $\mathcal{N} = 4$  supersymmetry were uncertain until the discovery of S-fold theories, where a genuine  $\mathcal{N} = 3$  theory is an  $\mathcal{N} = 3$  theory that never has the  $\mathcal{N} = 4$  supersymmetry. Since S-fold theories are constructed by using D3-branes in type IIB string theory, we can consider the AdS/CFT correspondence for S-fold theories [19, 20]. Thus, it is possible to investigate S-fold theories by using AdS/CFT. We apply our formula mentioned in the last paragraph to find the superconformal index of S-fold theories. Because it is conjectured that some of the S-fold theories are equivalent to  $\mathcal{N} = 4$  SYM with a certain gauge group (Aharony-Tachikawa conjecture) [20], we can compare our result with the index of corresponding  $\mathcal{N} = 4$  SYM. Moreover, the UV Lagrangian of some of the S-fold theories were given by Zafrir [21], and the index was calculated by using the UV Lagrangian. We can also compare our result with Zafrir's result.

The organization of this thesis is as follows.

In the rest of this chapter, we review some basic concepts to define the superconformal index and the BPS partition function. In particular, we review the Witten index, the conformal and superconformal symmetry. Then we define the superconformal index and the BPS partition function. We also discuss SCFTs for which the Lagrangian is not known.

In Chapter 2, we review the AdS/CFT correspondence between  $\mathcal{N} = 4$   $U(N)$  SYM and type IIB string theory on  $AdS_5 \times S^5$ . We start from the review of  $\mathcal{N} = 4$  SYM and give the superconformal index and the BPS partition function of  $\mathcal{N} = 4$   $U(N)$  SYM. After that, we see the elementary facts of type IIB string theory. Then we consider AdS/CFT correspondence. The agreement of the index and the BPS partition function in the large  $N$  limit is also reviewed.

In Chapter 3, we calculate the finite  $N$  corrections to the BPS partition function and the superconformal index following the author's and his collaborators' paper [22]. After the calculation, we compare our results with those on the CFT side.

In Chapter 4, we review the S-fold theories following [18–20]. First, we consider the orientifold and calculate the BPS partition function of  $\mathcal{N} = 4$   $SO(N)$  SYM. Then we define the S-fold and S-fold theories. We calculate the finite  $N$  corrections to the BPS partition function and the superconformal index following the author's and his collaborators' papers [22, 23]. The results of orientifold are compared with those on the CFT side. For S-fold theories, we also carry out the consistency check regarding the Aharony-Tachikawa conjecture [20] and the Zafrir's analysis [21].

Chapter 5 is devoted to conclusions and discussions.

We give the conventions for four-dimensional theories and notations of group theory in Appendix A.

In this thesis, we denote Napier's number, imaginary unit, and derivative in Roman type. We use the notation “Tr” only for traces of gauge group indices. Otherwise, we use “tr” for traces.

## 1.1 Partition function

A partition function is very important because we can read off the non-trivial information of a quantum theory. For example, the thermal partition function gives us the energy spectrum of a theory. The thermal partition function of a theory with the Hamiltonian  $H$  is given by

$$Z(\beta) = \text{tr}_{\mathcal{H}}(e^{-\beta H}) = \text{tr}_{\mathcal{H}}(q^H) = Z(q), \quad q = e^{-\beta}, \quad (1.1)$$

where the trace is taken over the Hilbert space of the theory, and  $\beta = 1/k_{\text{B}}T$  is the inverse temperature. Actually, the coefficients and exponents of the Taylor expansion of  $Z(q)$  with respect to  $q$  have information of the energy spectrum of the theory.

There is another expression of the partition function: the path integral form. Let us consider a quantum mechanical system of a particle. To see the path integral form, let us rewrite the partition function (1.1) by position eigenstates  $|x\rangle$ :

$$Z(\beta) = \int dx \langle x | e^{-\beta H} | x \rangle. \quad (1.2)$$

This is reminiscent of the transition amplitude. If we identify the Boltzmann factor with the time evolution operator, this is the transition amplitude with the time evolution  $t = -i\beta$ . Thus, the partition function can be written as the path integral with the periodic boundary condition:

$$Z(\beta) = \int \mathcal{D}x \exp \left[ i \int_0^{-i\beta} dt L(x, \dot{x}) \right], \quad x(0) = x(-i\beta), \quad (1.3)$$

where  $L(x, \dot{x})$  is the Lagrangian obtained by the Legendré transformation of the Hamiltonian.

In a quantum field theory, the fundamental degrees of freedom are not positions of particles but fields. Then the partition function of a quantum field theory is given by

$$Z = \int \mathcal{D}\Phi e^{iS[\Phi]}. \quad (1.4)$$

The time direction is compactified to  $S^1$ .

In the analysis of the quantum field theory, we often want to know the correlation

function because it encodes the scattering amplitudes through the Lehmann-Symanzik-Zimmermann reduction formula. As it is well known we add a source term  $J(x)$  coupled to the field  $\Phi$  in the action, and the correlation function  $\langle \Phi(x_1)\Phi(x_2)\cdots \rangle$  is

$$\langle \Phi(x_1)\Phi(x_2)\cdots \rangle = \frac{1}{Z[J=0]} \left( -i \frac{\delta}{\delta J(x_1)} \right) \left( -i \frac{\delta}{\delta J(x_2)} \right) \cdots Z[J] \Big|_{J=0}. \quad (1.5)$$

Then, we can read off what particles are present and how they interact with each other. This is one of the main goals of particle physics.

The benefits of the partition function are not limited to those mentioned above. For example, if the number of particles  $N$  is conserved, we can obtain the information regarding the number of particles as well as energy spectrum from the grand partition function:

$$\Xi(\beta, \mu) = \text{tr}(e^{-\beta H} e^{-\mu N}) = \text{tr}(q^H u^N) = Z(q, u), \quad q = e^{-\beta}, \quad u = e^{-\mu}, \quad (1.6)$$

where the trace is taken over all possible  $N$  values as well as Hilbert space with the constant  $N$  and  $\mu$  is the chemical potential. We refer to  $u$  as the fugacity. Thus the grand partition function is a generalization of the partition function by adding a number operator  $N$ , which commutes with the Hamiltonian.

Similarly, in general, we can add more information of the spectrum to the partition function by using the symmetries of the theory. If there are symmetries commuting with the Hamiltonian, we can generalize the partition function as follows because the symmetries do not change the structure of the eigenstates of the Hamiltonian:

$$Z(q, u_1, u_2, \cdots) = \text{tr}_V(q^H u_1^{F_1} u_2^{F_2} \cdots), \quad (1.7)$$

where  $F_1, F_2, \cdots$  commute each other and  $u_1, u_2, \cdots$  are also called the fugacities as an analogy of the grand partition function. The trace is taken over the Hilbert space of the theory. The commutativity means that we can choose  $F_j$  as the Cartan generators of the symmetries.

Actually, we can regard the partition function as a character in the context of the group theory. The character of a representation  $R$  of a group  $G$  is defined as the trace over the representation space  $V_R$ :

$$\chi_R(g) = \text{tr}_{V_R} R(g) = \sum_i [R(g)]_{ii}, \quad (1.8)$$

where  $R(g)$  is a representation matrix of an element  $g \in G$ . The partition function has the same structure. The Hilbert space is  $V_R$ . Hence the partition function is represented as a character of the state space with  $g = q^H u_1^{F_1} u_2^{F_2} \cdots$ .

Let us see the generalized partition function in the concrete example: 3d harmonic

oscillators. The Hamiltonian is given by

$$H = \sum_{i=1}^3 a_i^\dagger a_i, \quad (1.9)$$

where we neglect the zero-point energy for simplicity. The ordinary thermal partition function is now

$$Z(q) = \frac{1}{(1-q)^3} = 1 + 3q + 6q^2 + 10q^3 + 15q^4 + \dots. \quad (1.10)$$

Then we can read off the energy spectrum of this theory from the coefficients of fugacity  $q$  as promised. As you know, there is an  $SU(3)$  global symmetry of this system. Since the rank of  $SU(3)$  is two, we can define two fugacities coupled to the Cartan generators of  $SU(3)$ . The definition of the generalized partition function is

$$Z(q, u_1, u_2) = \text{tr}(q^H u_1^{R_1} u_2^{R_2}), \quad (1.11)$$

where  $R_1$  and  $R_2$  are the  $SU(3)$  Cartan generators. For the fundamental representation they are  $R_1 = \text{diag}(1, -1, 0)$  and  $R_2 = \text{diag}(0, 1, -1)$ . When the energy eigenvalue is  $n$  without the zero-point energy, it turns out that degenerating states belong to  $(n, 0)$  representation of  $SU(3)$ . The notation  $(n, 0)$  means the Dynkin label of  $SU(3)$ , and its definition is given in Appendix A.2. Hence the partition function is

$$Z(q, u_1, u_2) = \sum_{n=0}^{\infty} q^n \chi_{(n,0)}(u_1, u_2) = \frac{1}{(1-qu_1)(1-q\frac{u_2}{u_1})(1-q\frac{1}{u_2})}, \quad (1.12)$$

where  $\chi_{(n,0)}$  is defined by (A.34). Expanding the partition function with respect to  $q$ , we can find the energy spectrum with  $SU(3)$  charge information. Therefore, the generalized partition function tells us information about the theory in more detail.

The partition function (1.11) is expressed as the character as we introduced before. The Hamiltonian (1.9) is time independent, and it behaves as  $U(1)$  symmetry of the theory. So we can define the  $U(3)$  symmetry by combining this  $U(1)$  symmetry with the  $SU(3)$  symmetry. The number of the fugacities is the rank of  $U(3)$ , namely three. It is convenient to introduce linearly independent Cartan generators  $R_X$ ,  $R_Y$ , and  $R_Z$  of  $U(3)$  instead of  $H$ ,  $R_1$ , and  $R_2$ . The relation among them is  $H = R_X + R_Y + R_Z$ ,  $R_1 = R_X - R_Y$ , and  $R_2 = R_Y - R_Z$ . Let  $x$ ,  $y$ , and  $z$  be the corresponding fugacities to  $R_X$ ,  $R_Y$ , and  $R_Z$ . Then the new fugacities are related with the old ones as  $x = qu_1$ ,  $y = qu_2/u_1$ ,  $z = q/u_2$ . The definition (1.11) of the partition function is replaced by

$$Z(x, y, z) = \text{tr}_V(x^{R_X} y^{R_Y} z^{R_Z}). \quad (1.13)$$

This is just the character of  $U(3)$  (see (A.27)). Note that we have the  $(n, 0)$  representation

for  $n$ -th excited states, and we have to sum contributions from all possible representations. Therefore we have

$$Z(x, y, z) = \sum_{n=0}^{\infty} \bar{\chi}_{(n,0)}(x, y, z) = \frac{1}{(1-x)(1-y)(1-z)}, \quad (1.14)$$

where  $\bar{\chi}_{(n,0)}$  is defined by (A.32). This agrees with (1.12) with the replacement  $x = qu_1$ ,  $y = qu_2/u_1$ ,  $z = q/u_2$ .

Because the 3d harmonic oscillator is solvable, there are no obstacles to calculate the partition function. In the case of an interacting quantum field theory, if the theory is weakly coupled, we can use the perturbative expansion to obtain the partition function. It is very difficult to obtain the partition function in the strong coupling region due to the non-perturbative effects. However, we are often able to calculate the partition function exactly for supersymmetric theories. Then, we understand quantum field theories more deeply.

## 1.2 Witten index

In the presence of supersymmetry, we can define an important physical quantity that does not depend on the coupling constant. It is the Witten index [24]. The independence of the coupling constant enables us to calculate the Witten index exactly even for the strong coupling region, and we can learn something about the non-perturbative effects of the theory. Hence it is worthwhile to consider the Witten index.

In the supersymmetric theory, the supersymmetry algebra is defined as

$$\{\widehat{Q}^\dagger, \widehat{Q}\} = \widehat{\Delta}, \quad (1.15)$$

where  $\widehat{Q}$  is nilpotent, and the form of  $\widehat{\Delta}$  depends on the detail of the theory. In the supersymmetric quantum mechanics,  $\widehat{\Delta}$  is nothing but the Hamiltonian. In other theories such as superconformal field theories,  $\widehat{\Delta}$  is a certain combination of the symmetry generators. Because  $\widehat{\Delta}$  commutes with  $\widehat{Q}$  and  $\widehat{Q}^\dagger$ , an action of  $\widehat{Q}$  and  $\widehat{Q}^\dagger$  on an eigenstate of  $\widehat{\Delta}$  does not change its eigenvalue. Let us focus on an eigenstate  $|\psi\rangle$  with an eigenvalue  $\Delta$ . Then we can show that  $\Delta$  is positive-definite:

$$\Delta = \langle \psi | \widehat{\Delta} | \psi \rangle = |\widehat{Q}|\psi\rangle|^2 + |\widehat{Q}^\dagger|\psi\rangle|^2 \geq 0. \quad (1.16)$$

In what follows, we omit the hat symbol of operators for simplicity unless there is no confusion.

Now the Witten index of a supersymmetric theory with the supersymmetry algebra (1.15) is defined by

$$\mathcal{I}_{\text{Witten}}(\beta) = \text{tr}_{\mathcal{H}}[(-1)^F e^{-\beta\Delta}], \quad (1.17)$$

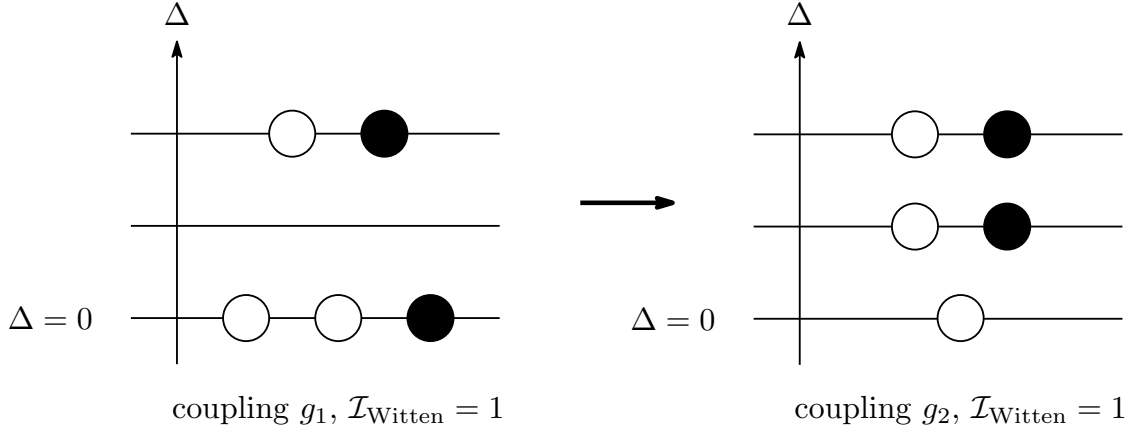

Fig. 1.1 The structure of states in a supersymmetric theory with supersymmetry algebra (1.15). Here a white node stands for a bosonic state, while a black node stands for a fermionic state. The coupling constant is  $g_1$  on the left side and  $g_2$  on the right side. The structure of states also changes if we change the coupling constant. However, the Witten index does not change because the excitation is always a pair of bosonic and fermionic states with the same eigenvalue.

where  $F$  is the fermion number operator and  $(-1)^F$  assigns the minus sign to fermionic states. Thus the Witten index can also be written as

$$\mathcal{I}_{\text{Witten}}(\beta) = \sum_{\text{bosons}} e^{-\beta\Delta_n} - \sum_{\text{fermions}} e^{-\beta\Delta_n}, \quad (1.18)$$

where  $n$  is a label of each state.

As we mentioned at the beginning of this section, the Witten index does not depend on the coupling constant. To see this, let us consider representations of the supersymmetry algebra (1.15). For  $\Delta > 0$  states, we can define a creation and annihilation operator  $a = Q/\sqrt{\Delta}, a^\dagger = Q^\dagger/\sqrt{\Delta}$  satisfying  $\{a^\dagger, a\} = 1$ . This is just the two-dimensional Clifford algebra, and we can define the Clifford vacuum as usual:  $a|\Omega\rangle = 0$ . We assume that the Clifford vacuum is a bosonic state. Due to the nilpotency of the supercharges, we have a two dimensional representation:  $(|\Omega\rangle, a^\dagger|\Omega\rangle)$ . This indicates that all states with  $\Delta > 0$  form a pair between a bosonic state and a fermionic state. Because supercharges commute with  $\Delta$ , this pair of the states has the same eigenvalue for  $\Delta$ . This means that contributions from  $\Delta > 0$  are always canceled. Therefore, the Witten index is only received from contributions of  $\Delta = 0$  states. If we change the coupling constant, some states may be excited. However, this excitation is always the pair of bosonic and fermionic states (see Fig. 1.1). Hence the excitation does not affect the Witten index, and that is why the Witten index is independent of the coupling constant. Strictly speaking, this discussion is applicable to any continuous parameter of the theory. In particular, the Witten index is an RG flow invariant.

The fact that the Witten index has contributions from  $\Delta = 0$  states only shows that

the Witten index is independent of  $\beta$ . Actually, we can also show it more directly.

$$\frac{d}{d\beta} \mathcal{I}_{\text{Witten}}(\beta) = \text{tr}_{\mathcal{H}} [(-1)^F \{Q^\dagger, Q\} e^{-\beta\{Q^\dagger, Q\}}] = 0, \quad (1.19)$$

where we used the cyclic symmetry of the trace and  $(-1)^F Q = -Q(-1)^F$ .

According to the above discussion, we also express the Witten index as

$$\mathcal{I}_{\text{Witten}}(\beta) = \#(\text{bosonic states with } \Delta = 0) - \#(\text{fermionic states with } \Delta = 0). \quad (1.20)$$

This expression may be more practical for the calculation.

We have seen that the Witten index receives the contribution from  $\Delta = 0$  states. Let  $|\psi\rangle$  be state with  $\Delta = 0$ . In fact, this state satisfies the following condition:

$$Q|\psi\rangle = Q^\dagger|\psi\rangle = 0. \quad (1.21)$$

We call this condition the Bogomol'nyi-Prasad-Sommerfield (BPS) condition and the state  $|\psi\rangle$  satisfying (1.21) is called the BPS state. This condition is a necessary and sufficient condition to be  $\Delta = 0$ . In this sense, the Witten index has the information of the BPS state spectrum of the theory.

As in the case of the thermal partition function, it is possible to generalize the Witten index to include the conserved charges associated with the global symmetries of the theory. However, we have an additional constraint: the generators of global symmetries should commute with the supercharges; otherwise, the discussion of independence of  $\beta$  is invalid. Then the generalized Witten index is defined by

$$\mathcal{I}(q, u_j) = \text{tr}_V [(-1)^F q^\Delta u_1^{F_1} u_2^{F_2} \cdots], \quad (1.22)$$

where  $q = e^{-\beta}$ , and we introduced the fugacities related to the symmetries. As we noted, we have constraints  $[Q, F_j] = 0$ . Again, this index tells us about the more detailed information of the BPS spectrum of the theory, and the index can be calculable even for the strong coupling region.

### 1.3 Localization

In this section, we explain how to calculate the Witten index in the Lagrangian theory. As we saw in the previous section, the partition function can be expressed as the path integral formalism in the quantum field theory. This is also the case for the Witten index. Due to the trace over the states, a spacetime manifold in which the path integral is carried out has a form  $\mathcal{X} \times S^1$ , where the period of  $S^1$  is the inverse temperature  $\beta$ . To ensure the convergence of the path integral, the space manifold  $\mathcal{X}$  must be compact.

In the path integral formalism, boundary conditions for fields are very important. In the thermal partition function, we impose the anti-periodic boundary condition of  $S^1$

for fermionic fields. Conversely, we have the fermion number operator  $(-1)^F$  in the definition of the Witten index, and we impose the periodic boundary condition even for fermionic fields as well as bosonic fields. Furthermore, the generalized Witten index has additional operators related to global symmetries. Then we have to include the effects of these additional operators on the boundary conditions. Let us consider a general trace  $\text{tr}[(-1)^F e^{-\beta\Delta}\mathcal{O}]$ . In the original Witten index  $\mathcal{O} = 1$  while in the generalized one  $\mathcal{O} = u_1^{F_1} u_2^{F_2} \dots$ . Then the boundary condition becomes

$$e^{-\beta\Delta}\mathcal{O}\Phi(\tau)\mathcal{O}^{-1}e^{\beta\Delta} = e^{\beta\partial_\tau}\mathcal{O}\Phi(\tau)\mathcal{O}^{-1}e^{-\beta\partial_\tau} = \mathcal{O}\Phi(\tau + \beta)\mathcal{O}^{-1} = \Phi(\tau), \quad (1.23)$$

where  $\Phi$  is a field, and  $\tau$  is a coordinate in  $S^1$ . With this boundary condition, the Witten index in the path integral formalism is

$$\mathcal{I}_{\text{Witten}} = \int_{\mathcal{X} \times S^1} \mathcal{D}\Phi e^{-S[\Phi]}, \quad (1.24)$$

where we performed the Wick rotation appropriately. Although it is difficult to carry out this path integral in general, the localization method [25] enables us to calculate the path integral exactly in the presence of the fermionic symmetry (e.g., supersymmetry).

In this thesis, we would like to apply the localization method to the Witten index. However, the localization method itself can be applied for various partition functions in a compact manifold  $\mathcal{M}$  with a fermionic symmetry. So let us review the general argument of the localization method in this subsection.

Let  $S$  be the action with fermionic symmetry:  $\delta_F S = 0$ , where  $\delta_F$  is nilpotent or its square becomes a certain bosonic symmetry  $\delta_B$  with  $\delta_B S = 0$ . Here we would like to evaluate the following path integral:

$$Z = \int_{\mathcal{M}} \mathcal{D}\Phi e^{-S[\Phi]}. \quad (1.25)$$

Instead of this, we consider the following deformed path integral:

$$Z(t) = \int_{\mathcal{M}} \mathcal{D}\Phi e^{-S[\Phi] - t\delta_F V[\Phi]}, \quad (1.26)$$

where  $V$  is a Grassmann odd functional satisfying  $\delta_B V = \delta_F^2 V = 0$ . We can reproduce  $Z$  by  $Z(t=0)$ . In fact, it is easy to show that  $Z(t)$  does not depend on  $t$ :

$$\begin{aligned} \frac{dZ(t)}{dt} &= - \int_{\mathcal{M}} \mathcal{D}\Phi \delta_F V e^{-S - t\delta_F V} \\ &= - \int_{\mathcal{M}} \mathcal{D}\Phi \delta_F (V e^{-S - t\delta_F V}) = -\delta_F \left( \int_{\mathcal{M}} \mathcal{D}\Phi \delta_F V e^{-S - t\delta_F V} \right) = 0, \end{aligned} \quad (1.27)$$

where we assumed the fermionic symmetry  $\delta_F$  is not anomalous. Thus, we can evaluate  $Z$  by  $Z(t)$  with any  $t$ . The simplest value of  $t$  to find  $Z$  is the  $t \rightarrow \infty$  limit. In this limit,

the path integral is dominated by saddle points of the deformation term  $\delta_F V$  with the assumption  $\delta_F V \geq 0$ . Then, only configurations satisfying  $\delta_F V[\Phi_0] = 0$  contribute to the integral. Let us expand  $S[\Phi]$  and  $\delta_F V[\Phi]$  around  $\Phi_0$  with the fluctuation  $t^{-\frac{1}{2}}\widehat{\Phi}$ . In the  $t \rightarrow \infty$  limit, residual path integral becomes

$$Z = \sum_{\Phi_0} \int_{\mathcal{M}} \mathcal{D}\widehat{\Phi} e^{-S[\Phi_0] - \widehat{\Phi} \delta_F V^{(2)}[\Phi_0] \widehat{\Phi}}, \quad (1.28)$$

where  $\delta_F V^{(2)}[\Phi_0]$  is the second-order derivative of the functional  $\delta_F V[\Phi]$ . It is happily the Gauss integral. We can perform the integral, and the result is the determinant of the linear operator  $\delta_F V^{(2)}$ . However, we have to pay attention to the existence of zero eigenvalues. If the operator  $\delta_F V^{(2)}$  has zero eigenvalues, we have to eliminate these zero eigenvalues and the integral remains for the corresponding component of the vector  $\Phi_0$ . Let  $a$  be such a component. Then, the final result is

$$Z = \sum_{\Phi_0} \int da \frac{\text{Det}_F(\delta_F V^{(2)}[\Phi_0])}{\text{Det}'_B(\delta_F V^{(2)}[\Phi_0])}, \quad (1.29)$$

where the prime in Det indicates the elimination of the zero eigenvalues. The important point of this result is that there are only finite number integrals. We call this determinant the one-loop determinant because it corresponds to the one-loop diagram in the absence of the non-perturbative effects.

## 1.4 Superconformal field theory

A theory with the superconformal symmetry is called a superconformal field theory (SCFT). The superconformal symmetry is essential for the definition of the superconformal index. First, we review the conformal symmetry, and second, we generalize it to superconformal symmetry to define the superconformal index in the latter subsection.

### 1.4.1 Conformal symmetry

The 4d conformal transformation in  $\mathbb{R}^{1,3}$  is generated by translations  $P_\mu$ , Lorentz transformations  $M_{\mu\nu}$ , dilatation  $D$ , and special conformal transformations  $K_\mu$ . They satisfy

the following commutation relations:

$$[D, P_\mu] = iP_\mu, \quad (1.30a)$$

$$[D, K_\mu] = -iK_\mu, \quad (1.30b)$$

$$[P_\mu, K_\mu] = -2iM_{\mu\nu} + 2i\eta_{\mu\nu}D, \quad (1.30c)$$

$$[M_{\mu\nu}, M_{\rho\sigma}] = i\eta_{\mu\rho}M_{\nu\sigma} - i\eta_{\mu\sigma}M_{\nu\rho} - i\eta_{\nu\rho}M_{\mu\sigma} + i\eta_{\nu\sigma}M_{\mu\rho}, \quad (1.30d)$$

$$[M_{\mu\nu}, P_\rho] = i\eta_{\mu\rho}P_\nu - i\eta_{\nu\rho}P_\mu, \quad (1.30e)$$

$$[M_{\mu\nu}, K_\rho] = i\eta_{\mu\rho}K_\nu - i\eta_{\nu\rho}K_\mu, \quad (1.30f)$$

where all the generators are Hermite. If we define generators  $M_{AB}$  ( $A, B = 0, 1, \dots, 5$ ) as

$$M_{AB} = \begin{pmatrix} M_{\mu\nu} & -\frac{1}{2}(P_\nu - K_\nu) & -\frac{1}{2}(P_\nu + K_\nu) \\ \frac{1}{2}(P_\mu - K_\mu) & 0 & D \\ \frac{1}{2}(P_\mu + K_\mu) & -D & 0 \end{pmatrix}, \quad (1.31)$$

then the commutation relations (1.30) are unified into a simple commutation relation:

$$[M_{AB}, M_{CD}] = i\eta_{AC}M_{BD} - i\eta_{AD}M_{BC} - i\eta_{BC}M_{AD} + i\eta_{BD}M_{AC} \quad (1.32)$$

with  $\eta_{AB} = \text{diag}(-1, 1, 1, 1, 1, -1)$ . This means that the conformal algebra is isomorphic to  $SO(2, 4)$ .

In CFTs, it is useful to consider the radial quantization instead of the vertical quantization. In the radial quantization, we define the theory on  $\mathbb{R} \times S^3$  instead of  $\mathbb{R}^{1,3}$ , and we regard  $\mathbb{R}$  as the time direction. The theory on  $\mathbb{R} \times S^3$  is related with the original theory on  $\mathbb{R}^{1,3}$  by the Weyl transformation of the metric:

$$g_{\mu\nu}(x) \rightarrow g'_{\mu\nu}(x) = e^{2w(x)}g_{\mu\nu}(x), \quad (1.33)$$

where  $w(x)$  is a certain real function of  $x$ . Note that in this manipulation, we need appropriate Wick rotations. Since the Weyl transformation preserves the structure of the conformal symmetry, the information of the original theory on  $\mathbb{R}^{1,3}$  is mapped into the theory on  $\mathbb{R} \times S^3$ . Now we can avoid the infra-red (IR) divergence due to the infinite volume of each time slice because the time slice is now  $S^3$ . This is the benefit of the radial quantization.

Now operators inserted at the origin in  $\mathbb{R}^{1,3}$  are mapped into states in the Hilbert space of the theory in  $\mathbb{R} \times S^3$ . Namely, we have a one-to-one correspondence between operators at the origin  $\mathcal{O}(0)$  in  $\mathbb{R}^{1,3}$  and states

$$|\mathcal{O}\rangle \equiv \mathcal{O}(0)|0\rangle \quad (1.34)$$

in  $\mathbb{R} \times S^3$ , where  $|0\rangle$  is the conformal invariant vacuum of a CFT. This is the so-called

operator-state correspondence. Thus we can find the operator spectrum of the theory in  $\mathbb{R}^{1,3}$  in terms of states in  $\mathbb{R} \times S^3$ . In what follows, the term ‘‘an operator’’ indicates ‘‘an operator inserted at the origin’’; otherwise, we will explain the meaning of ‘‘an operator.’’

It is useful to classify operators  $\mathcal{O}(0)$  in terms of representations of conformal algebra. First of all, an operator with the scaling dimension  $E$  is transformed under the dilatation as

$$[D, \mathcal{O}(0)] = iE\mathcal{O}(0). \quad (1.35)$$

Then, from the conformal algebra (1.30), we find that  $P_\mu$  and  $K_\mu$  have a role of raising and lowering the scaling dimension respectively:

$$[D, [P_\mu, \mathcal{O}(0)]] = i(E + 1)[P_\mu, \mathcal{O}(0)], \quad (1.36)$$

$$[D, [K_\mu, \mathcal{O}(0)]] = i(E - 1)[K_\mu, \mathcal{O}(0)]. \quad (1.37)$$

These are followed by the Jacobi identity. In the unitary theory, there is a lower bound to the scaling dimension. Thus the action of  $K_\mu$  terminates at a certain value of the scaling dimension. An operator with this scaling dimension is called the primary operator. Namely, the primary operator satisfies

$$[K_\mu, \mathcal{O}(0)] = 0. \quad (1.38)$$

As in the highest weight construction of the group theory, we can use the primary operator as a starting point to construct the conformal representation. Note that in the state picture, we call the corresponding state the primary state.

Before discussing conformal representation, let us give the conformal transformation laws for operators inserted at a generic point  $x$ . This operator  $\mathcal{O}(x)$  is related to the operator inserted at the origin by

$$\mathcal{O}(x) = e^{iP_\mu x^\mu} \mathcal{O}(0) e^{-iP_\mu x^\mu}. \quad (1.39)$$

Then the conformal transformation laws of an operator  $\mathcal{O}(x)$  are given by [26]

$$[P_\mu, \mathcal{O}(x)] = -i\partial_\mu \mathcal{O}(x), \quad (1.40a)$$

$$[M_{\mu\nu}, \mathcal{O}(x)] = [i(x_\mu \partial_\nu - x_\nu \partial_\mu) + \Sigma_{\mu\nu}] \mathcal{O}(x), \quad (1.40b)$$

$$[K_\mu, \mathcal{O}(x)] = [i(x^2 \partial_\mu - 2x_\mu x^\nu \partial_\nu - 2Ex_\mu) - 2x^\nu \Sigma_{\mu\nu}] \mathcal{O}(x), \quad (1.40c)$$

$$[D, \mathcal{O}(x)] = i(x^\mu \partial_\mu + E) \mathcal{O}(x), \quad (1.40d)$$

where  $\Sigma_{\mu\nu}$  is a spin matrix corresponding to the Lorentz transformation.

### Representations of conformal algebra

A conformal representation is uniquely specified by the Cartan charges of a primary operator. We have already seen that the conformal algebra is isomorphic to  $so(2,4)$ . Its subalgebra  $u(1) \times so(4)$  corresponds to the dilatation and the Lorentz transformation in  $\mathbb{R}^{1,3}$  respectively. Let  $j_L$  and  $j_R$  be the left- and right-handed spin. The dilatation charge is  $E$ . Then this primary operator is labeled by  $j_L, j_R$ , and  $E$ . We denote the label as

$$[j_L, j_R]_E. \quad (1.41)$$

We can construct a tower of operators (or states) by acting  $P_\mu$ . The operators (or states) generated by acting  $P_\mu$  on the primary operator (state) are called descendants. The labeling (1.41) can also be used for descendants.

There is one thing we have to pay attention to when the construction of representation. In fact, the zero norm states may appear in the tower of the representation. Corresponding operators are not physical. In order to make the theory unitary, we have to remove such states from the tower. Then such the tower is called a short representation.

As an example of a short representation, let us consider free massless primary scalar field  $\phi : [0, 0]_1$ . We can construct descendants by acting  $P_{\alpha\dot{\alpha}} \equiv \frac{1}{2}(\sigma^\mu)_{\alpha\dot{\alpha}} P_\mu : [\frac{1}{2}, \frac{1}{2}]_1$ . The result is

$$\begin{aligned} \phi : [0, 0]_1 &\xrightarrow{P_{\alpha\dot{\alpha}}} \partial_{\alpha\dot{\alpha}}\phi : [\frac{1}{2}, \frac{1}{2}]_2 \\ &\xrightarrow{P_{\alpha\dot{\alpha}}} \partial_{\{\alpha\{\dot{\alpha}}\partial_{\beta\}\dot{\beta}\}}\phi : [1, 1]_3 \oplus \epsilon^{\alpha\beta}\epsilon^{\dot{\alpha}\dot{\beta}}\partial_{\alpha\dot{\alpha}}\partial_{\beta\dot{\beta}}\phi : [0, 0]_3. \xrightarrow{P_{\alpha\dot{\alpha}}} \dots, \end{aligned} \quad (1.42)$$

where  $\partial_{\alpha\dot{\alpha}} = \frac{1}{2}(\sigma^\mu)_{\alpha\dot{\alpha}}\partial_\mu$ . Other irreducible combinations are vanished because  $\partial_{\alpha\dot{\alpha}}$ 's are commutative each other. Now the representation  $[0, 0]_3$  is in fact absence physically since it corresponds to the equation of motion of  $\phi$ :<sup>\*1</sup>

$$\epsilon^{\alpha\beta}\epsilon^{\dot{\alpha}\dot{\beta}}\partial_{\alpha\dot{\alpha}}\partial_{\beta\dot{\beta}}\phi \propto \partial^2\phi = 0. \quad (1.43)$$

In the state picture, the corresponding state is the zero norm state. It is possible to show this statement directly by calculating its norm. Hence we have to subtract this operator (or state) from the tower of descendants, and the representation becomes short.

### 1.4.2 Superconformal symmetry

In the presence of the supersymmetry and the conformal symmetry, the symmetry is enhanced to the superconformal symmetry. What supersymmetries survive on a general manifold is obtained by the Killing spinor equations. In the flat space, we have the

---

<sup>\*1</sup> The presence of a free massless scalar field means that we assume the presence of its Lagrangian  $\mathcal{L} = \partial_\mu\phi\partial^\mu\phi$  and as a result we have the equation of motion for  $\phi$ .

following Killing spinor equations:

$$\partial_\mu \epsilon_I = -i\sigma_\mu \bar{\kappa}_I, \quad \partial_\mu \bar{\epsilon}^I = -i\bar{\sigma}_\mu \kappa^I, \quad (1.44)$$

where  $\epsilon_I^\alpha$  ( $I = 1, \dots, \mathcal{N}$ ) is a parameter of the supersymmetry transformation and  $\kappa^I$  is an arbitrary spinor. The general solutions are given by

$$\epsilon_I = \eta_I - ix^\mu \sigma_\mu \bar{\zeta}_I, \quad \kappa^I = \zeta^I, \quad (1.45)$$

where  $\eta_I$  and  $\zeta^I$  are constant spinors. The first term corresponds to a supercharge  $Q_\alpha^I$ , and the second term corresponds to a supercharge  $\bar{S}_{\dot{\alpha}}^I$ . We also have their Hermite conjugations:  $\bar{Q}_I^{\dot{\alpha}}$  and  $S_I^\alpha$ . Namely, the Hermiticity of the supercharges is

$$(Q_\alpha^I)^\dagger = \bar{Q}_I^{\dot{\alpha}}, \quad (S_I^\alpha)^\dagger = \bar{S}_{\dot{\alpha}}^I. \quad (1.46)$$

They generate the following anti-commutation relations:

$$\{\bar{Q}_I^{\dot{\alpha}}, Q_\beta^J\} = \delta_I^J P^{\dot{\alpha}}{}_\beta, \quad (1.47a)$$

$$\{S_I^\alpha, \bar{S}_{\dot{\beta}}^J\} = -\delta_I^J K^\alpha{}_{\dot{\beta}}, \quad (1.47b)$$

$$\{S_I^\alpha, Q_\beta^J\} = \frac{i}{2} \delta_\beta^\alpha \delta_I^J D + i\delta_I^J M^\alpha{}_\beta + \delta_\beta^\alpha R^J{}_I, \quad (1.47c)$$

$$\{\bar{Q}_I^{\dot{\alpha}}, \bar{S}_{\dot{\beta}}^J\} = \frac{i}{2} \delta_{\dot{\beta}}^{\dot{\alpha}} \delta_I^J D + i\delta_I^J \bar{M}^{\dot{\alpha}}{}_{\dot{\beta}} - \delta_{\dot{\beta}}^{\dot{\alpha}} R^J{}_I, \quad (1.47d)$$

where  $R^I{}_J$  are generators of  $R$ -symmetry  $U(\mathcal{N})_R$  ( $\mathcal{N} \leq 3$ ) and  $SU(4)_R$  ( $\mathcal{N} = 4$ ) which are the rotation of the supercharges. For the convenience of a supersymmetric theory, we introduced the spinor indices for  $P, K$ , and  $M$  generators by

$$P_{\alpha\dot{\beta}} = -P_{\dot{\beta}\alpha} = \frac{1}{2}(\sigma^\mu)_{\alpha\dot{\beta}} P_\mu, \quad (1.48)$$

$$K_{\alpha\dot{\beta}} = -K_{\dot{\beta}\alpha} = \frac{1}{2}(\sigma^\mu)_{\alpha\dot{\beta}} K_\mu, \quad (1.49)$$

$$M_\alpha{}^\beta = \frac{1}{4}(\sigma^{\mu\nu})_\alpha{}^\beta M_{\mu\nu}, \quad (1.50)$$

$$\bar{M}^{\dot{\alpha}}{}_{\dot{\beta}} = \frac{1}{4}(\bar{\sigma}^{\mu\nu})^{\dot{\alpha}}{}_{\dot{\beta}} M_{\mu\nu}. \quad (1.51)$$

The transformation law of the fundamental and ant-fundamental representation of the  $R$ -symmetry is

$$[R^I{}_J, \phi_K] = \delta_K^I \phi_J - \frac{1}{4} \delta_J^I \phi_K, \quad [R^I{}_J, \phi^K] = -\delta_J^K \phi^I + \frac{1}{4} \delta_J^I \phi^K. \quad (1.52)$$

Then the generators of  $R$ -symmetry satisfy

$$[R^I{}_J, R^K{}_L] = \delta^I{}_L R^K{}_J - \delta^K{}_J R^I{}_L. \quad (1.53)$$

The commutation relation (1.52) indicates that for the  $\mathcal{N} = 4$  case, all the commutation relations of  $R^K{}_K$  vanish, so that the  $R$ -symmetry group is not  $U(4)_R$  but  $SU(4)_R$ .

Other commutators with supercharges are the following:

$$[D, Q^I_\alpha] = \frac{i}{2} Q^I_\alpha, \quad [D, \bar{Q}^{\dot{\alpha}}_I] = \frac{i}{2} \bar{Q}^{\dot{\alpha}}_I, \quad (1.54)$$

$$[D, S^\alpha_I] = -\frac{i}{2} S^\alpha_I, \quad [D, \bar{S}^I_{\dot{\alpha}}] = -\frac{i}{2} \bar{S}^I_{\dot{\alpha}}, \quad (1.55)$$

$$[K^\alpha{}_{\dot{\beta}}, Q^I_\gamma] = -\delta^\alpha_\gamma \bar{S}^I_{\dot{\beta}}, \quad [K^\alpha{}_{\dot{\beta}}, \bar{Q}^{\dot{\gamma}}_I] = -\delta^{\dot{\gamma}}_{\dot{\beta}} S^\alpha_I, \quad (1.56)$$

$$[P^{\dot{\alpha}}{}_\beta, S^\gamma_I] = -\delta^{\dot{\alpha}}_\beta \bar{Q}^{\dot{\gamma}}_I, \quad [P^{\dot{\alpha}}{}_\beta, \bar{S}^I_{\dot{\gamma}}] = -\delta^{\dot{\alpha}}_{\dot{\gamma}} Q^I_\beta. \quad (1.57)$$

As in the conformal symmetry, these commutation relations are unified with (1.30) into a simple relation. To see this, let us define the generators  $T^A{}_B$  ( $A = (\alpha, \dot{\alpha}, I)$ ) as

$$T^A{}_B = \begin{pmatrix} N^\alpha{}_\beta & K^\alpha{}_{\dot{\beta}} & \bar{S}^{\dot{\alpha}}_J \\ P^{\dot{\alpha}}{}_\beta & \bar{N}^{\dot{\alpha}}{}_{\dot{\beta}} & -\bar{Q}^{\dot{\alpha}}_J \\ Q^I_\beta & S^I_{\dot{\beta}} & R^I{}_J \end{pmatrix}, \quad (1.58)$$

where

$$N^\alpha{}_\beta = -\frac{i}{2} \delta^\alpha_\beta D + iM^\alpha{}_\beta - \frac{1}{4} \delta^\alpha_\beta R^K{}_K, \quad (1.59)$$

$$\bar{N}^{\dot{\alpha}}{}_{\dot{\beta}} = \frac{i}{2} \delta^{\dot{\alpha}}_{\dot{\beta}} D - i\bar{M}^{\dot{\alpha}}{}_{\dot{\beta}} - \frac{1}{4} \delta^{\dot{\alpha}}_{\dot{\beta}} R^K{}_K. \quad (1.60)$$

Then the superconformal algebra is unified into the following simple relation:

$$T^A{}_B T^C{}_D - \omega T^C{}_D T^A{}_B = \omega \delta^A{}_D T^C{}_B - \delta^C{}_B T^A{}_D, \quad (1.61)$$

$$\omega = (-1)^{(A+B)(C+D)}. \quad (1.62)$$

We defined  $(-1)^A$  as  $+1$  or  $-1$  depending on whether  $A$  is bosonic or fermionic (spinor) index. Note that the trace of  $T^A{}_B$  is zero:

$$N^\alpha{}_\alpha + \bar{N}^{\dot{\alpha}}{}_{\dot{\alpha}} + R^K{}_K = 0. \quad (1.63)$$

Therefore the 4d superconformal algebra is isomorphic to  $SU(2, 2|\mathcal{N})$  and for  $\mathcal{N} = 4$  isomorphic to  $PSU(2, 2|4)$  which is defined by removing the  $U(1)_R$  factor.

### Representations of the superconformal algebra

As in the case of the conformal representation, it is possible to define the superconformal primary operator satisfying

$$[S_{\dot{\alpha}}^I, \mathcal{O}(0)] = [\bar{S}_I^{\dot{\alpha}}, \mathcal{O}(0)] = 0. \quad (1.64)$$

Note that a conformal primary operator is not always a superconformal primary. However, its converse is true. Since the generator  $K^{\alpha}_{\dot{\alpha}}$  is roughly  $S\bar{S}$ , a superconformal primary operator is always a conformal primary. And operators constructed by acting  $Q$  on a superconformal primary operator are all conformal primary operators because  $K$  and  $S$  commute each other.

Then we can use supercharges  $Q_{\dot{\alpha}}^I$  and  $\bar{Q}_I^{\dot{\alpha}}$  as raising operators. From the commutation relations (1.54) and (1.55), we find that the raising operators raise the scaling dimension by half and the lowering operators  $S_{\dot{\alpha}}^I$  and  $\bar{S}_I^{\dot{\alpha}}$  lower the scaling dimension by half.

By using the raising operators  $Q$  and  $\bar{Q}$ , we also construct the tower of operators. Since we have already discussed conformal representations constructed by acting  $P_{\dot{\alpha}\alpha}$ , we here restrict our target to the conformal primary operators. Then we can regard the supercharges  $Q$  and  $\bar{Q}$  as nilpotent raising operators. Thus the tower must terminate if we use up all the raising operators. Then we call this representation long. Otherwise, there are certain non-physical operators (zero norm states), and the representation becomes short. We can consider conformal descendants for each conformal primary constructed by a superconformal primary, and finally, we obtain a superconformal representation.

The superconformal primary operators (states) and  $Q$ -excited ( $\bar{Q}$ -excited) operators (states) are labeled by not only the Lorentz spins  $j_L, j_R$  and the scaling dimension  $E$  but also the  $R$ -charges, where  $R$ -charges are the Cartan charges of the  $R$ -symmetry. So we use the notation

$$[j_L, j_R]_E^{(R\text{-charges})} \quad (1.65)$$

for the components of the superconformal representations.

We give the general structure of the superconformal representation in Fig. 1.2. For simplicity of the notation, we used the state picture.

### 1.4.3 Deformation of CFTs

In relativistic theories, it is believed that CFTs are realized at a fixed point of a renormalization group (RG) flow in which the beta-function is zero. Here we would like to consider deformations of a CFT. A deformation of a CFT is defined as an infinitesimal shift of this CFT from a fixed point in the space of RG flows. Roughly speaking, there are three classes of deformations:

- Adding local operators to the Lagrangian.

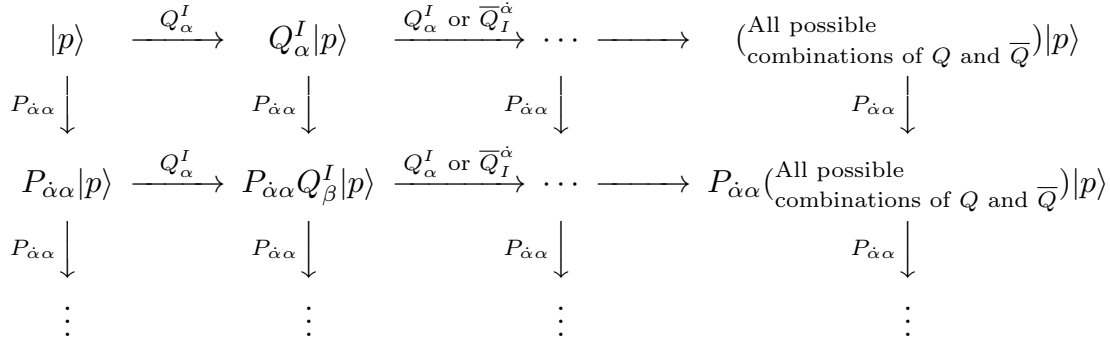

Fig. 1.2 An example of a general superconformal representation.  $|p\rangle$  stands for the superconformal primary state. In terms of operators  $Q_\alpha^I|\mathcal{O}\rangle$  is replaced by  $[Q_\alpha^I, \mathcal{O}]$ . The horizontal sequences correspond to the tower of  $Q$ -excited and  $\bar{Q}$ -excited states, and the vertical sequences correspond to the conformal descendants. The states located in the first row are all conformal primary.

- Gauging of a global symmetry.
- Moving onto a moduli space of vacua.

In this thesis, we focus on the first one: adding a local operator to the Lagrangian.

The adding of a local operator to the Lagrangian is the most common way to deform a CFT. This deforms the Lagrangian  $\mathcal{L}$  of a CFT as follows:

$$\delta\mathcal{L} = g\mathcal{O}. \quad (1.66)$$

Here  $g$  is an infinitesimal coupling constant, and  $\mathcal{O}$  is a local operator existing in the original CFT. For the original (undeformed) CFT  $g = 0$ . This deformation can also be defined even though we do not know the Lagrangian of the original CFT, by using the conformal perturbation theory [27].

Now we would like to restrict the class of an operator  $\mathcal{O}$  we treat in this thesis. First, we require that a deformation preserves the Lorentz symmetry, namely, an operator  $\mathcal{O}$  must be a scalar. Second, we require that an operator  $\mathcal{O}$  is a conformal primary of a conformal representation. Since  $\mathcal{O}$  exists in the original CFT, it is clear that  $\mathcal{O}$  belongs to a certain conformal representation. However, if  $\mathcal{O}$  were a conformal descendant, it would not change the bulk physics because a descendant operator can be written as derivatives of a certain operator. Thus  $\mathcal{O}$  should be a conformal primary.

Let  $\Delta_{\mathcal{O}}$  be the conformal dimension of a deformation operator  $\mathcal{O}$ . Then we can classify the deformation operator in three types by the value of  $\Delta_{\mathcal{O}}$ .

- Relevant operators ( $\Delta_{\mathcal{O}} < 4$ ): In this case, the corresponding coupling constant is called a relevant coupling constant. Then a CFT at  $g = 0$  is an ultraviolet (UV) fixed point. An RG flow is initiated by turning on the coupling constant, and the coupling constant in the infrared (IR) region grows. Thus the conformal

perturbation is eventually violated.

- Irrelevant operators ( $\Delta_{\mathcal{O}} > 4$ ): The corresponding coupling constant is called an irrelevant coupling constant. Now a CFT at  $g = 0$  is realized at an IR fixed point to which the irrelevant coupling gets smaller. The deformed CFT might be an effective theory of a certain UV theory.
- Marginal operators ( $\Delta_{\mathcal{O}} = 4$ ): The corresponding coupling constant is called a marginal coupling constant and dimensionless. The marginal deformation conserves the conformal symmetry at the leading order of the conformal perturbation. Then the deformation leads to a nearby fixed point for a small  $g$  enough. Including the effect of higher-order corrections, the marginal deformations are divided into marginally relevant, marginally irrelevant, and exactly marginal. An exactly marginal deformation preserves the conformal symmetry exactly.

Let us consider an exactly marginal deformation in detail. An exactly marginal deformation enables us to deform a CFT continuously, and parameters (coupling constants) of continuous deformations form a space of deformations for a CFT. Such a space is called a conformal manifold. Some of interacting CFTs can be constructed by continuous deformations from a free theory. Conversely, if there is no marginal deformation in a given CFT, this CFT does not connect with any free theories. Furthermore, even though there are marginal deformations, CFTs are not necessarily connected to a free theory.

#### 1.4.4 Theories for which the Lagrangian is unknown

For an interacting CFT connecting to a certain free theory, we can in principle give the Lagrangian by exactly marginal deformations. However, for a CFT which is not connected to a free theory, there is no general prescription to give the Lagrangian.

There may be the UV Lagrangian that flows to a target CFT. Although we do not know the Lagrangian of a target CFT, we can find the information about the CFT from the UV Lagrangian. In fact, although the Lagrangian is not known for AD theories, UV Lagrangians were found, and several physical quantities were discussed using the UV Lagrangian [10]. However, unfortunately, there is also no general prescription to find the UV Lagrangian.

In summary, it is quite difficult to discuss CFTs that are not connected to a free theory. The only way to discuss such a CFT is to use a duality.

In this thesis, we mainly focus on the  $\mathcal{N} = 4$  SYM and the S-fold theories. The former has the Lagrangian. On the other hand, the latter theories are CFTs that are not connected to a free theory. Then, it seems that there is no way to calculate physical quantities of S-fold theories<sup>\*2</sup>. However, fortunately, there is AdS/CFT for S-fold theories, and we may calculate the physical quantities of the S-fold theories through type IIB string

---

<sup>\*2</sup> Recently, UV theories of a part of S-fold theories were found [21], so they enable us to calculate physical quantities of such a part of S-fold theories. However, our calculation method we will give in the latter part of this thesis can be applied for general S-fold theories and is still useful.

theory on the AdS side. This analysis will be discussed in Chapter 4.

## 1.5 Superconformal index

So far, we have considered the general properties of CFTs and SCFTs. We also have seen that there is no prescription to give the Lagrangian and UV Lagrangian for CFTs that are not connected to a free theory. In this case, the only way to investigate such theories is to use a duality, as we saw in the last subsection. In fact, AdS/CFT enables us to analyze the S-fold theories. However, AdS/CFT is a strong/weak duality, and this is an obstruction to calculate various physical quantities. So we focus on the Witten index because it does not depend on the coupling constant. If a theory is an SCFT, the Witten index is specifically referred to as the superconformal index [16].

The superconformal index itself is defined in the state picture, namely defined on  $\mathbb{R} \times S^3$ , which ensures the convergence of the path integral. To define the superconformal index, we need the superconformal algebra on  $\mathbb{R} \times S^3$  instead of that on  $\mathbb{R}^{1,3}$ . The superconformal algebra on  $\mathbb{R} \times S^3$  is related to that on  $\mathbb{R}^{1,3}$  by the analog of the Wick rotation. Although we do not give the derivation, the transformation of the generators of the superconformal algebra from  $\mathbb{R}^{1,3}$  to  $\mathbb{R} \times S^3$  is given by

$$\begin{aligned} P^\alpha{}_\alpha &\rightarrow -P^\alpha{}_\alpha, & \bar{S}_I^\alpha &\rightarrow -\bar{S}_I^\alpha, & \bar{Q}_I^\alpha &\rightarrow -\bar{Q}_I^\alpha, \\ M^\alpha{}_\beta &\rightarrow -iJ^\alpha{}_\beta, & \bar{M}^{\dot{\alpha}}{}_{\dot{\beta}} &\rightarrow i\bar{J}^{\dot{\alpha}}{}_{\dot{\beta}}, & D &\rightarrow iH, \end{aligned} \quad (1.67)$$

and the Hermiticity of generators is changed. Concretely, the Hermiticity is given by

$$\begin{aligned} H^\dagger &= H, & (P^\alpha{}_\beta)^\dagger &= K^\beta{}_\alpha, \\ (J^\alpha{}_\beta)^\dagger &= J^\beta{}_\alpha, & (\bar{J}^{\dot{\alpha}}{}_{\dot{\beta}})^\dagger &= \bar{J}^{\dot{\beta}}{}_{\dot{\alpha}}, \\ (Q_I^\alpha)^\dagger &= S_I^\alpha, & (\bar{Q}_I^\alpha)^\dagger &= \bar{S}_I^\alpha. \end{aligned} \quad (1.68)$$

The important commutation relation to define the superconformal index is  $\Delta = \{\mathcal{Q}^\dagger, \mathcal{Q}\}$ , where  $\mathcal{Q}$  is one of the supercharges. We choose  $\mathcal{Q}$  as  $\bar{Q}_{I=1}^{\dot{\alpha}=1}$ . Let  $\bar{\Delta}$  be the commutation relation between  $\bar{Q}_1^1$  and its Hermite conjugate we have

$$\bar{\Delta} = 2\{\bar{Q}_1^1, \bar{S}_1^1\} = H - 2j_R - R^1{}_1, \quad (1.69)$$

where the factor 2 in front of the anti-commutation relation is just the convention to make our notation simpler.  $j_R$  is the right-handed spin operator  $\bar{J}^1{}_1$  and  $H$  is the Hamiltonian in the radial quantization.

Roughly speaking, the superconformal index is the Witten index in regard to the ‘‘supersymmetry (1.69)’’. As we saw in Sec. 1.2, we can add more fugacities corresponding to global symmetries commuting with  $\mathcal{Q}$  and  $\mathcal{Q}^\dagger$ . For superconformal theories, a part of

the conformal symmetry and other global symmetries commute with  $\mathcal{Q}$  and  $\mathcal{Q}^\dagger$ . Note that the  $R$ -symmetry does not commute with  $\mathcal{Q}$  and  $\mathcal{Q}^\dagger$  and only its subgroup commutes with them. We define flavor symmetries as global symmetries other than the conformal symmetry, which commute with  $\mathcal{Q}$  and  $\mathcal{Q}^\dagger$  including the subgroup of the  $R$ -symmetry.

Then the superconformal index is defined as

$$\mathcal{I}_{\text{SCI}} = \text{tr} \left[ (-1)^{F_{\bar{x}}} q^{H+j_R} y^{2j_L} \prod_i u_i^{F_i} \right], \quad (1.70)$$

where  $F_i$  is the Cartan generators of the flavor symmetries (or their linear combination) commuting with each other as well as  $\mathcal{Q}$  and  $\mathcal{Q}^\dagger$ . The contributions come from the  $\bar{\Delta} = 0$  states (BPS states) as we saw in Sec. 1.2. Namely, the index does not depend on  $\bar{x}$ .

As we mentioned before, the index is defined on  $\mathbb{R} \times S^3$ . Since we have the operator-state correspondence, it is possible to translate the BPS state spectrum in  $\mathbb{R} \times S^3$  into the BPS operator spectrum in  $\mathbb{R}^{1,3}$ , where the BPS operator  $\mathcal{O}_{\text{BPS}}$  is defined as operator satisfying

$$[\bar{Q}_1^{\dot{1}}, \mathcal{O}_{\text{BPS}}] = [\bar{S}_1^{\dot{1}}, \mathcal{O}_{\text{BPS}}] = 0. \quad (1.71)$$

Then the index also encodes the information of the BPS operator spectrum of the theory on  $\mathbb{R}^{1,3}$ .

Thus, since the index encodes the BPS spectrum and is independent of the coupling constant, it may be possible to find the BPS spectrum of the theory using AdS/CFT even for theories for which the Lagrangian is unknown. One of the goals of quantum field theories is to investigate its low energy effective theory (CFT) and to determine what types of operators and interactions exist. The fact that the combination of the index and AdS/CFT may actually achieve part of that goal is surprising and shows the importance of the index.

### 1.5.1 Chiral ring

Before explaining how to calculate the superconformal index, we need to comment on the properties of the BPS operators. States on  $\mathbb{R} \times S^3$  correspond to operators inserted into the origin on  $\mathbb{R}^{1,3}$ . In general, the composite operators are ill-defined at the same point in the spacetime. To make composite operators well-defined, we have to consider certain regularizations or operator product expansions (OPEs). Otherwise, the operator-state correspondence does not work for composite operators. However, the BPS operators are well-defined even for the composite operators inserted into the same point.

This statement can be understood in terms of the correlation function among BPS

operators. Actually, we can show

$$\frac{\partial}{\partial x_1^\mu} \langle \mathcal{O}(x_1) \mathcal{O}_2(x_2) \cdots \mathcal{O}_n(x_n) \rangle = 0, \quad (1.72)$$

where  $\mathcal{O}_i(x_i)$  is a BPS operator inserted at a point  $x_i$ . This equation states that the correlation function among BPS operators does not depend on the coordinates. Thus it is possible to define the correlation function even for  $x_1 = x_2 = \cdots = x_n$ . This is the statement we mentioned above.

Let us prove the statement (1.72). Then, it is useful to consider the chiral ring [28]. The chiral ring is defined in an  $\mathcal{N} = 1$  supersymmetric theory. If an operator  $\mathcal{O}$  satisfies

$$[\bar{Q}_{\dot{\alpha}}, \mathcal{O}] = 0 \quad (1.73)$$

for a certain  $\bar{Q}_{\dot{\alpha}}$ , we say that the operator  $\mathcal{O}$  belongs to the chiral ring. Namely, the chiral ring is a set of operators satisfying (1.73). We call operators satisfying (1.73) chiral operators.

The chiral operators are independent of the spacetime coordinates, up to  $\bar{Q}_{\dot{\alpha}}$ -commutators. From the commutation relation (1.40a) and (1.47a) we have

$$i(\sigma^\mu)_{\alpha\dot{\alpha}} \partial_\mu \mathcal{O}(x) = -(\sigma^\mu)_{\alpha\dot{\alpha}} [P_\mu, \mathcal{O}(x)] = 2\{\bar{Q}_{\dot{\alpha}}, [Q_\alpha, \mathcal{O}(x)]\}. \quad (1.74)$$

This implies that a correlation function among the chiral operators is independent of the spacetime coordinates:

$$\begin{aligned} & \frac{i}{2} (\sigma^\mu)_{\alpha\dot{\alpha}} \frac{\partial}{\partial x_1^\mu} \langle \mathcal{O}_1(x_1) \mathcal{O}_2(x_2) \cdots \mathcal{O}_n(x_n) \rangle \\ &= \langle \{\bar{Q}_{\dot{\alpha}}, [Q_\alpha, \mathcal{O}_1(x_1)]\} \mathcal{O}_2(x_2) \cdots \mathcal{O}_n(x_n) \rangle \\ &= - \sum_{k=2}^n \langle [Q_\alpha, \mathcal{O}_1(x_1)] \mathcal{O}_2(x_2) \cdots [\bar{Q}_{\dot{\alpha}}, \mathcal{O}_k(x_k)] \cdots \mathcal{O}_n(x_n) \rangle = 0. \end{aligned} \quad (1.75)$$

Therefore we finished the proof. Then we can take points of inserted operators freely. This enables us to do the cluster decomposition as follows:

$$\langle \mathcal{O}_1(x_1) \mathcal{O}_2(x_2) \cdots \mathcal{O}_n(x_n) \rangle = \langle \mathcal{O}_1 \rangle \langle \mathcal{O}_2 \rangle \cdots \langle \mathcal{O}_n \rangle. \quad (1.76)$$

Since the condition of the BPS operators (1.71) is just the chiral ring (1.73) for  $\dot{\alpha} = 1$ , the composite BPS operators make sense even for the same point. This is one of the reasons why we focus on the BPS operators.

### 1.5.2 Superconformal index for Lagrangian theories

As the end of this section, we review how to calculate the superconformal index in an SCFT with its Lagrangian. In Sec. 1.3, we saw that the Witten index can be calculated by the localization technique. Likewise, the superconformal index can also be in principle calculated by the localization technique using its Lagrangian. However, we have a more physical way called “free field counting” to obtain the same result with the localization. In this subsection, we review this way instead of the localization.

Since the superconformal index does not depend on the coupling constant  $g$ , we can evaluate the index at  $g = 0$ . Then the problem to calculate the index is what kinds of BPS operators exist in the theory. This can be read off from the Lagrangian. Then the procedure to find the index is the same as the harmonic oscillators.

In the case of the single harmonic oscillator, we have a state tower

$$|0\rangle, a^\dagger|0\rangle, (a^\dagger)^2|0\rangle, \dots, (a^\dagger)^k|0\rangle, \dots, \quad (1.77)$$

where  $|0\rangle$  a vacuum state. Then we call  $a^\dagger|0\rangle$  a single-particle state and a state whose form is  $(a^\dagger)^k|0\rangle$  is called a multi-particle state for  $k > 1$ . Similarly, when we have a BPS operator  $\mathcal{O}(x)$  which is not a composite operator in a CFT on  $\mathbb{R}^{1,3}$ , we have a state tower on  $\mathbb{R} \times S^3$  as

$$|0\rangle_{\text{CFT}}, \mathcal{O}(0)|0\rangle_{\text{CFT}}, (\mathcal{O}(0))^2|0\rangle_{\text{CFT}}, \dots, (\mathcal{O}(0))^k|0\rangle_{\text{CFT}}, \dots, \quad (1.78)$$

where  $|0\rangle_{\text{CFT}}$  is a conformal invariant vacuum state, and we call  $\mathcal{O}(0)|0\rangle_{\text{CFT}}$  and  $(\mathcal{O}(0))^k|0\rangle_{\text{CFT}}$  a single-particle BPS state and a multi-particle BPS state, respectively. Correspondingly, we call a BPS operator  $\mathcal{O}(x)$  a single-particle BPS operator, and  $\mathcal{O}(x)^k$  is called a multi-particle BPS operator. If there are several kinds of BPS operators, a BPS operator that is not made of any other operators is called a single-particle BPS operator. Conversely, a composite BPS operator is called a multi-particle BPS operator.

The first step of the free field counting is to consider the superconformal index of single-particle states. To do it, we need to list all the single-particle states. Let  $m_n(q, y, u_i)$  be a monomial of a contribution from a certain single-particle state to the index, where  $n$  is a label of a single-particle state. Then we can obtain the single-particle index by summing up all monomials corresponding to single-particle states in the list:

$$i_{\text{sp}}(q, y, u_i) = \sum_n c_n m_n(q, y, u_i), \quad (1.79)$$

where  $c_n$  is an integer corresponding to the number of a monomial  $m_n(q, y, u_i)$ .

The next step is to consider the multi-particle states. We have seen that the state structure (1.78) is the same as that of the single harmonic oscillator (1.77) for each single-particle BPS state. Namely, each single-particle BPS state corresponding to a monomial

$m_n(q, y, u_i)$  forms a single harmonic oscillator. Then a partition function of the single harmonic oscillator represented by a monomial  $m_n(q, y, u_i)$  without the zero point energy is given by

$$m_n(q, y, u_i) \rightarrow \frac{1}{1 - m_n(q, y, u_i)}. \quad (1.80)$$

This manipulation is called plethystic exponential. We denote this manipulation as

$$\text{Pexp}(m_n(q, y, u_i)) = \frac{1}{1 - m_n(q, y, u_i)}. \quad (1.81)$$

When the theory has some harmonic oscillators, the total partition function is given by the product of each partition function:

$$\text{Pexp}\left(\sum_n c_n m_n(q, y, u_i)\right) = \prod_n \frac{1}{(1 - m_n(q, y, u_i))^{c_n}}. \quad (1.82)$$

It seems that this manipulation is valid only for bosonic operators. However, in fact, this is valid even for fermionic operators due to the extra minus sign. In the ordinary partition function in which the temporal boundary condition of a fermionic operator is anti-periodic, the fermionic contribution is given by  $1 + m_n$ , where  $m_n$  is a monomial corresponding to a fermionic contribution. On the other hand, in the index, the temporal boundary condition is periodic as in the case of bosons, and we have an extra minus sign in front of the monomial:  $-m_n$ . The index is then given by  $1 - m_n$ , which is the same result as applying the plethystic exponential to  $-m_n$ . Therefore, the plethystic exponential (1.82) is applicable to both bosonic and fermionic single-particle BPS operators.

One more manipulation is needed to find the index for gauge theories. In general, the BPS operators are charged under the gauge interaction, and the index would depend on the gauge fugacity  $z_a$  ( $a = 1, \dots, \text{rank}G$ ), where  $G$  is the gauge group. However, only the gauge invariant BPS operators contribute in gauge theories because the index is a kind of partition function. Thus the index is gauge invariant and independent of the gauge fugacities. Also, when we discuss the AdS/CFT correspondence, there is no corresponding symmetry to the gauge symmetry on the AdS side. Then the physical quantities on the CFT side, which we should compare with corresponding quantities on AdS sides, should be gauge invariant. Conversely, this is also why we focus on the gauge invariant BPS operators and the superconformal index.

In order to extract the gauge invariant components, we have to perform the gauge integral with the Haar measure defined by

$$\int_G d\mu \equiv \frac{1}{|\mathcal{W}_G|} \prod_{a=1}^{\text{rank}G} \oint_{|z_a|=1} \frac{dz_a}{2\pi i z_a} \text{Pexp}(\chi_{\text{adj}}^G(z_a) - \text{rank}G), \quad (1.83)$$

where  $|\mathcal{W}_G|$  is the order of the Weyl group  $\mathcal{W}_G$  and  $\chi_{\text{adj}}^G(z_a)$  is the character of the adjoint representation of the gauge group  $G$ . Actually, the Haar measure is obtained by the zero mode integral in the localization. Finally, the index that counts the gauge invariant BPS operators for Lagrangian theories is given by

$$\mathcal{I}_{\text{SCI}}(q, y, u_i) = \int_G d\mu \text{Pexp}(i_{\text{sp}}(q, y, u_i, z_a)), \quad (1.84)$$

where  $i_{\text{sp}}(q, y, u_i, z_a)$  is the single-particle index including the gauge fugacities. In this way, we can find the superconformal index of an SCFT with its Lagrangian.

We have an additional comment for the plethystic exponential (1.82). There is another expression of the plethystic exponential. To obtain this expression, we rewrite the right hand side of (1.82) by using  $f = \exp(\log f)$ :

$$\begin{aligned} \text{Pexp}(i_{\text{sp}}(q, y, u_i)) &= \exp \left[ - \sum_n c_n \log(1 - m_n(q, y, u_i)) \right] \\ &= \exp \left[ \sum_n \sum_{k=1}^{\infty} \frac{c_n m_n(q, y, u_i)^k}{k} \right] \\ &= \exp \left[ \sum_{k=1}^{\infty} \frac{1}{k} i_{\text{sp}}(q^k, y^k, u_i^k) \right], \end{aligned} \quad (1.85)$$

where  $i_{\text{sp}}(q, y, u_i) = \sum_n c_n m_n(q, y, u_i)$  with the monomial  $m_n(q, y, u_i)$ . We use these two formulas (1.82) and (1.85) depending on the situation.

We have a comment for the free field counting. In fact, the free field counting is not always valid for the calculation of the superconformal index. In general, BPS operators can acquire the anomalous dimension. In this case, the superconformal index calculated by the localization is not in agreement with that calculated by the free field counting. For the  $\mathcal{N} = 4$  SYM, BPS operators do not acquire the anomalous dimension, and we can use the free field counting.

## 1.6 BPS partition function

There is another important supersymmetric partition function named BPS partition function. It includes only contributions from the BPS primary scalar operators. Thus the discussion of the Witten index is not applicable to the BPS partition function and in general the BPS partition function depends on the coupling constant. As a result, the form of the BPS partition function of the interacting theory is different from that of the free theory<sup>\*3</sup>. However, the structure of the BPS partition function is quite simple, and we can calculate

---

<sup>\*3</sup> The BPS spectrum of primary scalar operators is invariant for the non-zero coupling constant [16,28]. Then, all we have to do is to take into account the spectrum at  $g = 0$  and the spectrum for  $g \neq 0$ , where  $g$  is a coupling constant.

the BPS partition function even for interacting theories. Furthermore, the BPS partition function gives us a significant hint to search the structure of the superconformal index. Thus, study of the BPS partition function is important.

The definition of the BPS partition function is given by

$$Z(u_i) = \text{tr}_{\text{BPS scalars}} \left[ \prod_i u_i^{F_i} \right], \quad (1.86)$$

where  $F_i$  are charges of the global symmetries. Like the superconformal index, we can read off the BPS primary scalar operator spectrum from this.

For free theories, the BPS partition function can be evaluated by the free field counting. On the other hand, there is no general method to calculate the BPS partition function for interacting theories. In particular, the localization technique is not applicable to the BPS partition function.

In this thesis, we calculate the BPS partition function for the  $\mathcal{N} = 4$  SYM and S-fold theories. The BPS partition function of the  $\mathcal{N} = 4$  SYM has been well studied because the BPS partition function can be calculated as a certain invariant polynomial of the Weyl group of a gauge group. On the other hand, the S-fold theories are not a gauge theory, and no one had calculated the BPS partition function for S-fold theories except for the author's and his collaborators' research [23]. In Chapter 4, we will explain the BPS partition function of the S-fold theories.



## Chapter 2

# AdS/CFT Correspondence

In this chapter, we review the AdS/CFT correspondence between the four-dimensional (4d)  $\mathcal{N} = 4$   $U(N)$  supersymmetric Yang-Mills (SYM) theory and type IIB superstring theory on  $AdS_5 \times S^5$ . This chapter aims to introduce the essential and basic concepts of the AdS/CFT correspondence. We also review the BPS partition function and the superconformal index for  $\mathcal{N} = 4$   $U(N)$  SYM. Since the large  $N$  limit of the AdS/CFT correspondence for  $\mathcal{N} = 4$  SYM have been well studied, the agreement of the BPS partition function and the superconformal index were already confirmed<sup>\*1</sup>. We also see this agreement.

First, we review  $\mathcal{N} = 4$  SYM and its properties. Then we calculate the BPS partition function and the superconformal index for  $\mathcal{N} = 4$   $U(N)$  SYM. Second, we review the string theory and its properties necessary to see the AdS/CFT correspondence. Third, we consider the AdS/CFT correspondence by using the D3-brane, which is a 3+1-dimensional object existing in type IIB string theory. Finally, we confirm the agreement of the BPS partition function and the superconformal index in AdS/CFT.

## 2.1 Four-dimensional $\mathcal{N} = 4$ supersymmetric Yang-Mills theory

Here we would like to discuss  $\mathcal{N} = 4$  SYM. This theory has  $\mathcal{N} = 4$  supersymmetry and the maximally supersymmetric theory without gravity. It is believed that  $\mathcal{N} = 4$  SYM is the only theory having  $\mathcal{N} = 4$  supersymmetry. In addition to the supersymmetry,  $\mathcal{N} = 4$  SYM also has the conformal symmetry, and hence the theory has  $\mathcal{N} = 4$  superconformal symmetry. Namely,  $\mathcal{N} = 4$  SYM is an SCFT.

$\mathcal{N} = 4$  SYM has a vector multiplet composed of a gauge field  $A_\mu$ , gauginos  $\lambda_I$  and

---

<sup>\*1</sup> Since the structure of the BPS partition function is easy, the agreement of the BPS partition function in the finite  $N$  region was also confirmed [29]. However, the investigation of the BPS partition function gives us a great insight to find the finite  $N$  corrections to the superconformal index on the AdS side and still important. The analysis in regard to the finite  $N$  corrections will be given in Chapter 3.

	$R_X$	$R_Y$	$R_Z$	$SO(6)_R$
$Q^4$	$\frac{1}{2}$	$\frac{1}{2}$	$-\frac{1}{2}$	$\bar{4}$
$Q^3$	$\frac{1}{2}$	$-\frac{1}{2}$	$\frac{1}{2}$	
$Q^2$	$-\frac{1}{2}$	$\frac{1}{2}$	$\frac{1}{2}$	
$Q^1$	$-\frac{1}{2}$	$-\frac{1}{2}$	$-\frac{1}{2}$	
$\bar{Q}_1$	$\frac{1}{2}$	$\frac{1}{2}$	$\frac{1}{2}$	4
$\bar{Q}_2$	$\frac{1}{2}$	$-\frac{1}{2}$	$-\frac{1}{2}$	
$\bar{Q}_3$	$-\frac{1}{2}$	$\frac{1}{2}$	$-\frac{1}{2}$	
$\bar{Q}_4$	$-\frac{1}{2}$	$-\frac{1}{2}$	$\frac{1}{2}$	

Table 2.1 The  $SO(6)_R$  Cartan charges of supercharges.  $Q^I$ 's belong to  $\bar{4} \in SO(6)_R$ , while  $\bar{Q}_I$ 's belong to  $4 \in SO(6)_R$ .

$\bar{\lambda}^I$ , and adjoint scalar fields  $\phi_{IJ} = -\phi_{JI}$ .  $I, J = 1, 2, 3, 4$  are the spinor indices of the  $SO(6)_R \simeq SU(4)_R$  symmetry, which is the rotation symmetry of four supercharges  $Q^I$ . The four-dimensional spinor conventions is given in Appendix A.1. We define the Cartan generators of  $SO(6)_R$  as  $R_X$ ,  $R_Y$ , and  $R_Z$ . These generators are related to the  $R$ -symmetry generators  $R^I{}_J$  defined in subsection 1.4.2 as

$$R_X = \frac{1}{2}(R^1{}_1 + R^2{}_2 - R^3{}_3 - R^4{}_4), \quad (2.1a)$$

$$R_Y = \frac{1}{2}(R^1{}_1 - R^2{}_2 + R^3{}_3 - R^4{}_4), \quad (2.1b)$$

$$R_Z = \frac{1}{2}(R^1{}_1 - R^2{}_2 - R^3{}_3 + R^4{}_4). \quad (2.1c)$$

The upper and lower indices of  $Q^I$  and  $\bar{Q}_I$  correspond to  $\bar{4}$  and 4, respectively. The  $SO(6)_R$  Cartan charges of supercharges are listed in Table 2.1. We also list field contents of  $\mathcal{N} = 4$  SYM in Table 2.2. Note that the scalar field  $\phi_{IJ}$  satisfies the reality condition

$$\bar{\phi}^{IJ} = \frac{1}{2}\epsilon^{IJKL}\phi_{KL}. \quad (2.2)$$

Thus  $\phi_{IJ}$  has the three independent complex scalar fields X, Y, and Z. We define these three complex scalar fields as

$$X = \phi_{12}, \quad Y = \phi_{13}, \quad Z = \phi_{14}. \quad (2.3)$$

For the gauge field  $A_\mu$ , its field strength  $F_{\mu\nu}$  can be decomposed into the self dual part  $F_\alpha{}^\beta$  and anti-self dual part  $\bar{F}^{\dot{\alpha}}{}_{\dot{\beta}}$  as

$$F_\alpha{}^\beta = \frac{1}{4}(\sigma^{\mu\nu})_\alpha{}^\beta F_{\mu\nu}, \quad \bar{F}^{\dot{\alpha}}{}_{\dot{\beta}} = \frac{1}{4}(\bar{\sigma}^{\mu\nu})^{\dot{\alpha}}{}_{\dot{\beta}} F_{\mu\nu}. \quad (2.4)$$

Fields	$SO(6)_R$
$\phi_{IJ}$	6
$\lambda_I$	4
$\bar{\lambda}^I$	$\bar{4}$
$F_{\mu\nu}$	1

Table 2.2 Fields contents of the  $\mathcal{N} = 4$  SYM with their representation of  $SO(6)_R$ .

The Lagrangian of the  $\mathcal{N} = 4$  SYM on  $\mathbb{R}^{1,3}$  is given by

$$\begin{aligned} \mathcal{L}_{\text{SYM}}^{\mathcal{N}=4} = & \frac{1}{g^2} \text{Tr} \left[ -\frac{1}{2} F_{\mu\nu} F^{\mu\nu} + i \bar{\lambda}^I \bar{\sigma}^\mu D_\mu \lambda_I + \frac{1}{4} D_\mu \bar{\phi}^{IJ} D^\mu \phi_{IJ} \right. \\ & \left. + \frac{1}{2} \lambda_I [\lambda_J, \bar{\phi}^{IJ}] + \frac{1}{2} \bar{\lambda}^I [\bar{\lambda}^J, \phi_{IJ}] + \frac{1}{32} [\bar{\phi}^{IJ}, \bar{\phi}^{KL}] [\phi_{IJ}, \phi_{KL}] \right] + \frac{\theta}{16\pi^2} \text{Tr}(F_{\mu\nu} \tilde{F}^{\mu\nu}), \end{aligned} \quad (2.5)$$

where  $\tilde{F}^{\mu\nu}$  is defined by

$$\tilde{F}^{\mu\nu} = \frac{1}{2} \epsilon^{\mu\nu\rho\sigma} F_{\rho\sigma}. \quad (2.6)$$

The Lagrangian (2.5) is invariant under the  $\mathcal{N} = 4$  supersymmetric transformation given by

$$\delta_Q A_\mu(x) = i(\bar{\eta}^I \bar{\sigma}_\mu \lambda_I + \eta_I \sigma_\mu \bar{\lambda}^I), \quad (2.7a)$$

$$\delta_Q \lambda_I(x) = -\frac{1}{2} F_{\mu\nu} \sigma^{\mu\nu} \eta_I + D_\mu \phi_{IJ} \sigma_\mu \bar{\eta}^J - \frac{i}{2} [\phi_{IJ}, \bar{\phi}^{JK}] \eta_K, \quad (2.7b)$$

$$\delta_Q \phi_{IJ}(x) = 2i(\eta_I \lambda_J - \eta_J \lambda_I - \epsilon_{IJKL} \bar{\eta}^K \bar{\lambda}^L). \quad (2.7c)$$

Here the action  $\delta_Q$  on a field  $\Phi(x)$  is defined as

$$\delta_Q \Phi(x) \equiv [\eta_I Q^I + \bar{\eta}^I \bar{Q}_I, \Phi(x)]. \quad (2.8)$$

Furthermore, the Lagrangian (2.5) is also invariant under the super-conformal transformation

$$\delta_S A_\mu(x) = -x^\nu \lambda_I \sigma_\mu \bar{\sigma}_\nu \zeta^I - x^\nu \bar{\lambda}^I \bar{\sigma}_\mu \sigma_\nu \bar{\zeta}_I, \quad (2.9a)$$

$$\delta_S \lambda_I(x) = \frac{i}{2} F_{\mu\nu} x^\lambda \sigma^{\mu\nu} \sigma^\lambda \bar{\zeta}_I - i D_\mu \phi_{IJ} x_\nu \sigma^\mu \bar{\sigma}^\nu \zeta^J + 2i \phi_{IJ} \zeta^J + \frac{1}{2} [\phi_{IJ}(x), \bar{\phi}^{JK}] x^\mu \sigma_\mu \bar{\zeta}_K, \quad (2.9b)$$

$$\delta_S \phi_{IJ}(x) = -2x^\mu (\bar{\zeta}_I \bar{\sigma}_\mu \lambda_J - \bar{\zeta}_J \bar{\sigma}_\mu \lambda_I - \epsilon_{IJKL} \zeta^K \sigma_\mu \bar{\lambda}^L). \quad (2.9c)$$

Here we also define the

$$\delta_S \Phi(x) \equiv [\zeta^I S_I + \bar{\zeta}_I \bar{S}^I, \Phi(x)]. \quad (2.10)$$

We can show that the transformations  $\delta_Q$  and  $\delta_S$  satisfy the  $\mathcal{N} = 4$  superconformal algebra. Let us focus on  $\delta_Q$  as an example. Then we can calculate a commutation relation  $[\delta_Q, \delta'_Q] \Phi(x)$  as follows:

$$[\delta_Q, \delta'_Q] \Phi(x) = [[\eta_I Q^I + \bar{\eta}^I Q_I, \eta'_I Q^I + \bar{\eta}'^I \bar{Q}_I], \Phi(x)], \quad (2.11)$$

where  $\delta'_Q \Phi(x)$  is defined by (2.8) with the replacement  $\eta \rightarrow \eta'$  and  $\bar{\eta} \rightarrow \bar{\eta}'$ . When we choose  $\Phi(x)$  as the adjoint scalar field  $\phi_{IJ}$ , we find

$$[\delta_Q, \delta'_Q] \phi_{IJ} = 2i \partial_\mu \phi_{IJ} \eta_K \sigma^\mu \bar{\eta}'^K - 2i \partial_\mu \phi_{IJ} \eta'_K \sigma^\mu \bar{\eta}^K. \quad (2.12)$$

This means that

$$[\{\bar{Q}_I^\alpha, Q_\beta^J\}, \phi_{KL}] = [-2\delta_I^J (\sigma^\mu)_\beta^\alpha P_\mu, \phi_{KL}]. \quad (2.13)$$

Thus we derived the same commutation relation as (1.47a). In this way, we can obtain all the anti-commutation relations (1.47) among fermionic generators. We can also show that the Lagrangian (2.5) is invariant under the conformal transformation using (1.40). Therefore, the Lagrangian (2.5) indeed has  $\mathcal{N} = 4$  superconformal symmetry on  $\mathbb{R}^{1,3}$ .

The beta function of  $\mathcal{N} = 4$  SYM is zero. Since the theory includes four Weyl spinor fields  $\lambda_I$  and three complex scalar fields defined by (2.3), the one-loop beta function becomes

$$\beta(g) \propto -\frac{g^3}{16\pi^2} \left( \frac{11}{3} - \frac{1}{3} \cdot 3 - \frac{2}{3} \cdot 4 \right) = 0, \quad (2.14)$$

and this is consistent with the superconformal symmetry.

It is often useful to define the complex coupling constant  $\tau$  as

$$\tau = \frac{\theta}{2\pi} + \frac{4\pi i}{g^2}. \quad (2.15)$$

Let us consider the marginal deformation of  $\mathcal{N} = 4$  SYM. To see it, we rescale the definition of the fields as

$$A_\mu \rightarrow g A_\mu, \quad \phi_{IJ} \rightarrow g \phi_{IJ}, \quad \lambda_I \rightarrow g \lambda_I. \quad (2.16)$$

Fields	$\mathcal{N} = 4$ ( $Q^{1,2,3,4}$ )	$\mathcal{N} = 2$ ( $Q^{1,4}$ )	$\mathcal{N} = 1$ ( $Q^1$ )
$(X, \lambda^2)$	vector multiplet	hypermultiplet	chiral multiplet
$(Y, \lambda^3)$			chiral multiplet
$(Z, \lambda^4)$		vector multiplet	chiral multiplet
$(A_\mu, \lambda^1)$			vector multiplet

Table 2.3 The  $\mathcal{N} = 2$  and  $\mathcal{N} = 1$  decomposition of the  $\mathcal{N} = 4$  vector multiplet. The  $\mathcal{N} = 2$  supersymmetry is generated by  $Q^{1,4}$  and its conjugate and the  $\mathcal{N} = 1$  supersymmetry is generated by  $Q^1$  and its conjugate.

Then the Lagrangian (2.5) is changed as

$$\begin{aligned} \mathcal{L} = \text{Tr} \left[ -\frac{1}{2} F_{\mu\nu} F^{\mu\nu} + i \bar{\lambda}^I \bar{\sigma}^\mu D_\mu \lambda_I + \frac{1}{4} D_\mu \bar{\phi}^{IJ} D^\mu \phi_{IJ} \right. \\ \left. + \frac{g}{2} \lambda_I [\lambda_J, \bar{\phi}^{IJ}] + \frac{g}{2} \bar{\lambda}^I [\bar{\lambda}^J, \phi_{IJ}] + \frac{g^2}{32} [\bar{\phi}^{IJ}, \bar{\phi}^{KL}] [\phi_{IJ}, \phi_{KL}] \right], \end{aligned} \quad (2.17)$$

where we neglect the topological term  $F_{\mu\nu} \tilde{F}^{\mu\nu}$ . Then we can split the Lagrangian into two parts: the free part and the interacting part. The conformal dimension of the interacting part is four, and  $g$  is dimensionless. Therefore, all interacting terms are regarded as the marginal deformations, and  $\mathcal{N} = 4$  SYM has the marginal deformations and connects to a free theory. Note that  $\mathcal{N} = 4$   $U(1)$  Maxwell theory is always a free theory because all interacting terms vanish.

### 2.1.1 $\mathcal{N} = 1, 2$ decomposition

It is helpful to decompose the  $\mathcal{N} = 4$  vector multiplet into the  $\mathcal{N} = 1, 2$  multiplets. Here we choose  $Q^{1,4}$  and  $\bar{Q}_{1,4}$  as supercharges of the  $\mathcal{N} = 2$  subalgebra. For  $\mathcal{N} = 1$  subalgebra we use  $Q^1$  and  $\bar{Q}_1$ . Then the  $\mathcal{N} = 4$  vector multiplet splits into the  $\mathcal{N} = 2$  vector multiplet and the  $\mathcal{N} = 2$  hypermultiplet as follows:

$$(X, Y, Z, \lambda_I, F_{\alpha\beta})_{\text{vector}}^{\mathcal{N}=4} \rightarrow (Z, \lambda_{1,4}, F_{\alpha\beta})_{\text{vector}}^{\mathcal{N}=2} \oplus (X, Y, \lambda_{2,3})_{\text{hyper}}^{\mathcal{N}=2}, \quad (2.18)$$

where we only consider the self dual part of the gauge field and its superpartner. Similarly, the  $\mathcal{N} = 4$  vector multiplet splits into the  $\mathcal{N} = 1$  vector multiplet and three  $\mathcal{N} = 1$  chiral multiplets as

$$(X, Y, Z, \lambda_I, F_{\alpha\beta})_{\text{vector}}^{\mathcal{N}=4} \rightarrow (\lambda_1, F_{\alpha\beta})_{\text{vector}}^{\mathcal{N}=1} \oplus (X, \lambda_2)_{\text{chiral}}^{\mathcal{N}=1} \oplus (Y, \lambda_3)_{\text{chiral}}^{\mathcal{N}=1} \oplus (Z, \lambda_4)_{\text{chiral}}^{\mathcal{N}=1}. \quad (2.19)$$

We summarize these decomposition in Table 2.3.

For calculating the BPS partition function, it is convenient to classify the BPS operators of  $\mathcal{N} = 4$  SYM in terms of the  $\mathcal{N} = 1, 2$  language. First, we define the chiral primary

Operators	Supercharges
TrX	$Q^{3,4}, \bar{Q}_{1,2}$
TrY	$Q^{2,4}, \bar{Q}_{1,3}$
TrZ	$Q^{2,3}, \bar{Q}_{1,4}$

Table 2.4 Examples of chiral primary operators and supercharges annihilating them.

operators as superconformal primary operators annihilated by a certain combination of supercharges  $Q^I, \bar{Q}_I$ . Examples of the chiral primary operators are the adjoint scalar operators TrX, TrY, and TrZ. The trace is taken in the adjoint representation of the gauge group and necessary for making operators gauge invariant. The super-conformal transformation of the adjoint scalar fields (2.9c) vanishes at the origin. Thus the adjoint scalar operators (inserted at the origin) are indeed the superconformal primary operators. Also, the supersymmetry transformation rules up to numerical coefficients, which can be read off from (2.7c), are

$$[Q_\alpha^I, \phi_{JK}] \propto \delta_J^I \lambda_{K\alpha} - \delta_K^I \lambda_{J\alpha}, \quad [\bar{Q}_I^\alpha, \phi_{JK}] \propto \epsilon_{IJKL} \bar{\lambda}^{L\alpha}. \quad (2.20)$$

Then we can see the adjoint scalar operators TrX, TrY, TrZ defined by (2.3) are annihilated by some of the supercharges. We list which supercharges annihilate the adjoint scalar operators in Table 2.4. That is why the adjoint scalar operators TrX, TrY, TrZ are the chiral primary operators. Note that  $\bar{Q}_1$  annihilates all the adjoint scalar operators TrX, TrY, TrZ.

Next, we would like to define the term “ $\frac{k}{16}$ -BPS operators”. The  $\frac{k}{16}$ -BPS operators are the BPS operators annihilated by  $k$  supercharges of  $\{Q_\alpha^I, \bar{Q}_I^\alpha | I = 1, 2, 3, 4, \alpha = 1, 2, \dot{\alpha} = \dot{1}, \dot{2}\}$ . The number of total supercharges are sixteen, so  $k$  can take value from 1 to 16. Let us consider the several examples. First, operators consisting of Z are annihilated by  $Q_\alpha^{2,3}$  and  $\bar{Q}_{1,4}^\alpha$ , so they are  $\frac{1}{2}$ -BPS operators. Second, operators consisting of X and Y are annihilated by  $Q_\alpha^4$  and  $\bar{Q}_1^\alpha$ , so they are  $\frac{1}{4}$ -BPS operators. Finally, operators consisting of X, Y, and Z are annihilated by  $\bar{Q}_1^\alpha$ , so they are  $\frac{1}{8}$ -BPS operators.

### 2.1.2 Coulomb branch and Higgs branch

Here we would like to discuss the Coulomb branch and the Higgs branch. They are the moduli space of a given theory, which is defined as the set of vacua. Let us consider a gauge theory with the gauge group  $G$  and a potential term  $V(\phi)$ , where  $\phi$  is a scalar field of this theory. We assume that the minimum value of  $V(\phi)$  is zero. Then the moduli space is given by a set of vacua, which is specified by the vacuum expectation value (VEV) of  $\phi$  satisfying  $V(\phi) = 0$ . Furthermore, we need to remove the gauge redundancy from a set

of vacua. Then the moduli space  $\mathcal{M}$  is defined by

$$\mathcal{M} \equiv \{\phi | V(\phi) = 0\} / G. \quad (2.21)$$

Let us consider an  $\mathcal{N} = 2$  gauge theory. Then, there is the  $\mathcal{N} = 2$  vector multiplet composed of  $(\phi, \lambda, \psi, A_\mu)$ , where  $\phi$  is an adjoint scalar field,  $\lambda$  and  $\psi$  are Weyl spinor fields, and  $A_\mu$  is the gauge field. In general, the adjoint scalar field  $\phi$  has a potential term

$$V(\phi) \propto \text{Tr}[\phi, \bar{\phi}]^2 \quad (2.22)$$

The minimum condition  $V(\phi) = 0$  gives the VEV of  $\phi$  as

$$\langle \phi \rangle = \sum_{a=1}^{\text{rank}G} c_a H^a, \quad (2.23)$$

where  $c_a$  is a complex parameter and  $H^a$  is the Cartan generator of the gauge group  $G$ . The residual gauge redundancy is the Weyl transformation of  $G$ . Then the moduli space is given by  $\mathbb{C}^{\text{rank}G} / \mathcal{W}$ , where  $\mathcal{W}$  is the Weyl group of  $G$ . This moduli space is parameterized by the gauge invariant Casimir operators and called the Coulomb branch. Also, we call Casimir operators parameterizing the Coulomb branch the Coulomb branch operators.

A similar discussion can be made for the matter sector. Here we consider an  $\mathcal{N} = 2$  gauge theory with a hypermultiplet composed of  $(\bar{\psi}_{\tilde{q}}, q, \tilde{q}, \psi_q)$ , where  $\bar{\psi}_{\tilde{q}}, \psi_q$  are Weyl spinor fields and  $q, \tilde{q}$  are complex scalar fields. The hypermultiplet belongs to a certain representation of  $G$ . If there is a potential term for a field in the hypermultiplet, the VEV of this field defines vacua, which forms the moduli space. This moduli space is called the Higgs branch. The Casimir operators parameterizing the Higgs branch are called the Higgs branch operators. We can also define the mixed branch by using both vector multiplet and hypermultiplet.

Now let us apply above discussion to  $\mathcal{N} = 4$  SYM with the gauge group  $G$ . From the  $\mathcal{N} = 2$  perspective, the theory has the vector multiplet  $(Z, \lambda_{1,4}, F_{\alpha\beta})$  and the hypermultiplet  $(X, Y, \lambda_{2,3})$  as we have seen in (2.18). The potential term of adjoint scalar fields  $X, Y, Z$  is given by

$$V(X, Y, Z) = \frac{1}{32g^2} [\phi_{IJ}, \phi_{KL}] [\bar{\phi}^{IJ}, \bar{\phi}^{KL}] = -\frac{1}{2g^2} \sum_{\Phi, \Phi' = X, Y, Z, \bar{X}, \bar{Y}, \bar{Z}} [\Phi, \Phi']^2. \quad (2.24)$$

Since  $Z$  sits on the vector multiplet, the minimum condition

$$V(X, Y, Z) \supset V(Z) = -\frac{1}{g^2} [Z, \bar{Z}]^2 = 0 \quad (2.25)$$

gives the Coulomb branch of this theory. Similarly, since  $X$  and  $Y$  sit on the hypermultiplet,

the minimum condition

$$V(\mathbf{X}, \mathbf{Y}, \mathbf{Z}) \supset V(\mathbf{X}, \mathbf{Y}) = -\frac{1}{2g^2} \sum_{\Phi, \Phi'=\mathbf{X}, \mathbf{Y}, \bar{\mathbf{X}}, \bar{\mathbf{Y}}} [\Phi, \Phi']^2 = 0 \quad (2.26)$$

gives the Higgs branch. The minimum condition

$$V(\mathbf{X}, \mathbf{Y}, \mathbf{Z}) = 0 \quad (2.27)$$

gives the mixed branch. The moduli spaces for the Coulomb branch, the Higgs branch, the mixed branch are  $\mathbb{C}^{\text{rank}G}/\mathcal{W}_G, \mathbb{C}^{2\text{rank}G}/\mathcal{W}_G, \mathbb{C}^{3\text{rank}G}/\mathcal{W}_G$ , respectively.

### 2.1.3 BPS partition function

In this subsection, we would like to discuss the BPS partition function of the  $\mathcal{N} = 4$   $U(N)$  SYM. According to the discussion in Sec. 1.6, we can define the BPS partition function by using the global symmetries of  $\mathcal{N} = 4$  SYM, namely  $SO(6)_R$ . Thus the BPS partition function is defined by

$$Z(x, y, z) = \text{tr}_{\text{BPS}}(x^{R_X} y^{R_Y} z^{R_Z}), \quad (2.28)$$

where the trace is taken over the gauge invariant BPS operators consisting of the adjoint scalar fields  $\mathbf{X}$ ,  $\mathbf{Y}$ , and  $\mathbf{Z}$ . The BPS condition for an operator  $\mathcal{O}$  is here given by

$$[\bar{Q}_1, \mathcal{O}] = 0. \quad (2.29)$$

An operator  $\mathcal{O}$  satisfying this condition is a  $\frac{1}{8}$ -BPS operator. In this sense, the BPS partition function (2.28) is called the  $\frac{1}{8}$ -BPS partition function. Then the BPS partition function have the information of the BPS operator spectrum for operators consisting of  $\mathbf{X}, \mathbf{Y}, \mathbf{Z}$ . Note that we do not consider the operators including  $\bar{\mathbf{X}}, \bar{\mathbf{Y}}$ , and  $\bar{\mathbf{Z}}$  because these fields do not satisfy the BPS condition (2.29).

We can impose another BPS condition for the trace. If we impose

$$[Q^2, \mathcal{O}] = [Q^3, \mathcal{O}] = [\bar{Q}_1, \mathcal{O}] = [\bar{Q}_4, \mathcal{O}] = 0 \quad (2.30)$$

as BPS conditions, the operators satisfying these conditions are  $\frac{1}{2}$ -BPS operators and composed of  $\mathbf{Z}$ . Because the  $R$ -charges of  $\mathbf{Z}$  are  $(R_X, R_Y, R_Z) = (0, 0, 1)$ , the corresponding BPS partition function is derived by setting  $x = y = 0$  in  $Z(x, y, z)$ . We call this BPS partition function the  $\frac{1}{2}$ -BPS partition function. Also, since  $\mathbf{Z}$  sits in the  $\mathcal{N} = 2$  vector multiplet, this BPS partition function is often called the Coulomb branch Hilbert series.

We can also impose the following BPS conditions:

$$[Q^4, \mathcal{O}] = [\bar{Q}_4, \mathcal{O}] = 0. \quad (2.31)$$

Then the operators satisfying these conditions are  $\frac{1}{4}$ -BPS operators and composed of  $X$  and  $Y$ . Because the  $R$ -charges of  $X$  and  $Y$  are  $(R_X, R_Y, R_Z) = (1, 0, 0), (0, 1, 0)$ , the corresponding BPS partition function is derived by setting  $z = 0$  in  $Z(x, y, z)$ . We call this BPS partition function the  $\frac{1}{4}$ -BPS partition function. Also, since  $X$  and  $Y$  belong to the  $\mathcal{N} = 2$  hypermultiplet, this BPS partition function is often called the Higgs branch Hilbert series.

In this section, we are interested in the  $\mathcal{N} = 4$   $U(N)$  SYM. In this case, the gauge invariant BPS operators are simply trace operators consisting of  $X, Y, Z$ . Although the determinant operators are also gauge invariant operators, we do not consider them because the determinant operators can be written in terms of the trace operators. The reason is as follows. For the determinant operators in the  $\mathcal{N} = 4$   $U(N)$  SYM, we use two epsilon tensors like  $\epsilon_{ij\dots} \epsilon^{kl\dots} \Phi_k^i \Phi_l^j \dots$ . Then the epsilon tensors can be written in terms of the Kronecker deltas. Thus the determinant operators can be written by a certain combination of the trace operators.

We also comment on the Pfaffian operators. It is roughly adjoint fields contracted by one epsilon tensor. The precise definition is given in (4.6). In the  $U(N)$  case, this cannot be a gauge invariant operator since it is impossible to contract all the indices of adjoint fields by one epsilon tensor. Thus, the Pfaffian operators are absent in the  $U(N)$  gauge theory. However, the gauge invariant Pfaffian operators exist in the  $SO(2N)$  gauge theory, and they play a significant role in Chapter 4.

### Free theory

Here we discuss the BPS partition function of the  $\mathcal{N} = 4$   $U(N)$  SYM at  $g = 0$ . In this case, we can use the free field counting to find the BPS partition function. Because all gauge invariant BPS operators are obtained as a combination of  $X, Y, Z$ , the BPS partition function for  $g = 0$  can be derived from the following formula:

$$Z_{U(N)}(x, y, z) = \int_{U(N)} d\mu \text{Pexp}[(x + y + z)\chi_{\text{adj}}^{U(N)}], \quad (2.32a)$$

$$\int_{U(N)} d\mu = \frac{1}{N!} \prod_{i=1}^N \int_{|z_i|=1} \frac{dz_i}{2\pi i z_i} \prod_{j \neq k} \left(1 - \frac{z_j}{z_k}\right), \quad (2.32b)$$

$$\chi_{\text{adj}}^{U(N)} = \sum_{i,j=1}^N \frac{z_i}{z_j}, \quad (2.32c)$$

where the Haar measure (2.32b) is obtained by the formula (1.83). Therefore, the formula (2.32) contains terms for operators corresponding to all combinations of gauge invariant

BPS operators. We show the BPS partition functions for small ranks below:

$$Z_{U(1)}^{\text{free}}(x, y, z) = \frac{1}{(1-x)(1-y)(1-z)}, \quad (2.33)$$

$$Z_{U(2)}^{\text{free}}(x, y, z) = \frac{1 + xyz}{(1-x)(1-y)(1-z)(1-x^2)(1-y^2)(1-z^2)(1-xy)(1-yz)(1-zx)}. \quad (2.34)$$

Let us consider the physical meaning of the BPS partition function given above. For simplicity, we set  $x = y = z = q$ . Expanding  $Z_{U(2)}^{\text{free}}(q, q, q)$  with respect to  $q$ , we find

$$Z_{U(2)}^{\text{free}}(q, q, q) = 1 + 3q + 12q^2 + 29q^3 + \dots \quad (2.35)$$

The coefficients describe the number of BPS operators having the same conformal dimension in each term because the BPS condition (2.29) means  $R_X + R_Y + R_Z = E$  where  $E$  is the conformal dimension. Let us focus on the term  $12q^2$  as an example. Actually, we can find the following BPS operators with  $E = 2$ :

$$\begin{aligned} & \text{Tr}(\mathbf{X}^2), \quad \text{Tr}(\mathbf{Y}^2), \quad \text{Tr}(\mathbf{Z}^2), \quad \text{Tr}(\mathbf{XY}), \quad \text{Tr}(\mathbf{YZ}), \quad \text{Tr}(\mathbf{ZX}), \\ & (\text{Tr}\mathbf{X})^2, \quad (\text{Tr}\mathbf{Y})^2, \quad (\text{Tr}\mathbf{Z})^2, \quad (\text{Tr}\mathbf{X})(\text{Tr}\mathbf{Y}), \quad (\text{Tr}\mathbf{Y})(\text{Tr}\mathbf{Z}), \quad (\text{Tr}\mathbf{Z})(\text{Tr}\mathbf{X}). \end{aligned} \quad (2.36)$$

The number of these BPS operators is 12. Thus the BPS partition function indeed has the information of the BPS operator spectrum as coefficients of the fugacities.

For  $\mathcal{N} = 4$   $SU(N)$  SYM, the BPS partition function can be obtained by dividing the  $U(N)$  BPS partition function (2.32) by the  $U(1)$  BPS partition function (2.33):

$$Z_{SU(N)} = \frac{Z_{U(N)}}{Z_{U(1)}}. \quad (2.37)$$

For example, the  $SU(2)$  BPS partition function is given by

$$Z_{SU(2)}^{\text{free}} = \frac{1 + xyz}{(1-x^2)(1-y^2)(1-z^2)(1-xy)(1-yz)(1-zx)}. \quad (2.38)$$

Although the  $\frac{1}{2}$ -BPS partition function can be obtained by  $Z_{U(N)}^{\text{free}}(0, 0, z)$ , we have another derivation for the  $\frac{1}{2}$ -BPS partition function. Since the  $\frac{1}{2}$ -BPS operators consist of  $\mathbf{Z}$  only, we can find all the  $\frac{1}{2}$ -BPS operators directly. These are  $\{\text{Tr}\mathbf{Z}^n | n = 1, \dots, N\}$  and their composite operators. Namely, we can regard the single trace operators  $\{\text{Tr}\mathbf{Z}^n\}$  as the single-particle operators of the  $\frac{1}{2}$ -BPS operators. Thus the  $\frac{1}{2}$ -BPS partition function becomes

$$Z_{U(N)}^{\text{free}}(0, 0, z) = \text{Pexp} \left( \sum_{n=1}^N z^n \right) = \prod_{n=1}^N \frac{1}{1 - z^n}. \quad (2.39)$$

Actually, we can show that

$$\int_{U(N)} d\mu_P \exp(z\chi_{\text{adj}}^{U(N)}) = \prod_{n=1}^N \frac{1}{1-z^n}. \quad (2.40)$$

### Interacting theory

Let us consider the BPS partition function for the interacting theory,  $g \neq 0$ . In general, the form of the BPS partition function in  $g \neq 0$  is different from that at  $g = 0$  because some of the BPS operators acquire the quantum correction, and they are no longer the BPS operator in  $g \neq 0$ . However, the BPS partition functions in the weak coupling region and the BPS partition functions in the strong coupling region agree with each other [16, 28]. For  $U(1)$  Maxwell theory, all fields in the Lagrangian (2.17) are commutative with each other, so there is no interaction terms and the  $U(1)$  BPS partition function in  $g \neq 0$  is the same as that at  $g = 0$ .

First, the  $\frac{1}{2}$ -BPS partition function is the same as that in the free theory (2.39), because the ingredient to make the  $\frac{1}{2}$ -BPS operators is the only  $Z$ , and we need not take the interaction into account.

It is not so easy to find the  $\frac{1}{8}$ -BPS partition function for the interacting theory because there are non-trivial relations called syzygies [30] among the single trace operators. For example, in the  $U(2)$  SYM, we find the following relation

$$\text{Tr}(\{X, Y\}Z) = (\text{Tr}X)(\text{Tr}YZ) + (\text{Tr}Y)(\text{Tr}ZX) + (\text{Tr}Z)(\text{Tr}XY) - (\text{Tr}X)(\text{Tr}Y)(\text{Tr}Z). \quad (2.41)$$

and the operator  $\text{Tr}(\{X, Y\}Z)$  does not contribute to the  $U(2)$  BPS partition function.

A more systematic way to count the independent BPS operators satisfying (2.29) is to use the chiral ring generated by  $\overline{Q}_1$ . As we have seen in subsection 1.5.1, the chiral ring is defined in an  $\mathcal{N} = 1$  theory. Now we regard  $\mathcal{N} = 4$  SYM as an  $\mathcal{N} = 1$  theory, where supercharges are  $Q^1$  and  $\overline{Q}_1$ . Then the interaction terms regarding the adjoint scalars are treated as the potential terms (2.24), and they should be reproduced by the superpotential from the  $\mathcal{N} = 1$  perspective. The superpotential  $W(\Phi_i)$  that reproduce the potential term should satisfy an equation

$$\frac{\delta W}{\delta \Phi_i} \propto g^2 \epsilon_{ijk} \text{Tr}[\Phi_j, \Phi_k], \quad (2.42)$$

where  $\Phi_{i=x,y,z}$  are  $\mathcal{N} = 1$  chiral multiplets including the scalar field  $X, Y, Z$ , respectively. Furthermore, it follows that

$$\frac{\delta W}{\delta \Phi_i} \propto [\Phi_i^*]_F \quad (2.43)$$

from an equation of motion for a general homogeneous superpotential consisting of a chiral multiplet  $\Phi_i$ , where  $[\ ]_F$  means picking up the  $F$ -term of the anti-chiral multiplet  $\Phi_i^*$ .

Thanks to the  $F$ -term condition, we regard the commutation relation  $[\Phi_i, \Phi_j]$  as zero, and for the adjoint scalar fields, we have

$$[\mathbf{X}, \mathbf{Y}] = [\mathbf{Y}, \mathbf{Z}] = [\mathbf{Z}, \mathbf{X}] = 0. \quad (2.44)$$

Therefore, we regard these scalar fields as Cartan valued adjoint matrices of the gauge group. This condition is actually the same as the minimum condition of the potential (2.24). Thus the BPS operators consisting of  $\mathbf{X}, \mathbf{Y}, \mathbf{Z}$  parametrize the moduli space  $\mathbb{C}^{3N}/\mathcal{W}_{U(N)}$ , where  $\mathcal{W}_{U(N)} = S_N$  is the Weyl group of  $U(N)$ .

Now we can diagonalize  $\mathbf{X}, \mathbf{Y}, \mathbf{Z}$  simultaneously and let  $x_i, y_i, z_i$  be the diagonal components. The Weyl transformation acts on  $x_i, y_i, z_i$  as  $x_{\sigma(i)}, y_{\sigma(i)}, z_{\sigma(i)}$ , where  $\sigma \in S_N$ . Then the  $\frac{1}{8}$ -BPS operators are polynomials of these  $N$  variables invariant under the Weyl transformation. We can use the following polynomials as bases of the invariant polynomial.

$$\sum_{\sigma \in S_N} \prod_{i=1}^N x_{\sigma(i)}^{m_i^x} y_{\sigma(i)}^{m_i^y} z_{\sigma(i)}^{m_i^z}, \quad (2.45)$$

where the set of three integers  $\{m_i^x, m_i^y, m_i^z\}$  labels the basis. We can regard (2.45) as the wave function of the three-dimensional harmonic oscillator. The symmetrization  $\sum_{\sigma \in S_N}$  is now interpreted as the Bose statistics. Therefore, the wave function (2.45) is regarded as that of the system with  $N$  bosonic particles in the harmonic potential.

The  $\frac{1}{8}$ -BPS grand partition function is the same as the grand partition function of this system and given by

$$\begin{aligned} \Xi_{U(*)}^{\frac{1}{8}\text{-BPS}}(x, y, z; t) &= \sum_{N=0}^{\infty} Z_{U(N)}^{\frac{1}{8}\text{-BPS}}(x, y, z) t^N \\ &= \prod_{p, q, r=0}^{\infty} \frac{1}{1 - tx^p y^q z^r} = \text{Pexp} \left( \frac{t}{(1-x)(1-y)(1-z)} \right). \end{aligned} \quad (2.46)$$

The  $\frac{1}{2}$ -BPS and  $\frac{1}{4}$ -BPS grand partition functions can be obtained by setting  $x = y = 0$  and  $z = 0$  respectively. In particular, we can show that

$$\Xi_{U(*)}^{\frac{1}{2}\text{-BPS}}(z; t) = \prod_{r=0}^{\infty} \frac{1}{1 - tz^r} = \sum_{N=0}^{\infty} \left( \prod_{n=0}^N \frac{1}{1 - z^n} \right) t^N \quad (2.47)$$

by using the  $q$ -binomial theorem, and the coefficient of  $t^N$  indeed agrees with (2.39).

It is easier to obtain the BPS partition functions for small ranks by expanding the grand

partition function (2.46) with respect to  $t$ . The results for  $N = 1, 2$  are

$$Z_{U(1)}^{\frac{1}{8}\text{-BPS}} = \frac{1}{(1-x)(1-y)(1-z)}, \quad (2.48)$$

$$Z_{U(2)}^{\frac{1}{8}\text{-BPS}} = \frac{1 + xy + yz + zx}{(1-x)(1-y)(1-z)(1-x^2)(1-y^2)(1-z)^2}. \quad (2.49)$$

In these examples, we see that the  $U(1)$  BPS partition function indeed agrees with that of the free theory (2.33), as we mentioned at the beginning of this sub-subsection. On the other hand, the  $U(2)$  partition function is completely different from the free  $U(2)$  partition function (2.34).

To see the difference between (2.34) and (2.49) clearer, let us expand the  $U(2)$  BPS partition function (2.49) with respect to  $x = y = z \equiv q$ . The result is

$$Z_{U(2)}^{\frac{1}{8}\text{-BPS}}(q, q, q) = 1 + 3q + 12q^2 + 28q^3 + \dots \quad (2.50)$$

We see that the term  $28q^3$  deviates from the term in (2.35) by  $q^3$ . The origin of this deviation comes from the fact that a degree three BPS operator  $\text{Tr}([X, Y]Z)$  is no longer contributes to the BPS partition function because of the commutativity (2.44).

### 2.1.4 Superconformal index

Another example of the physical quantities we would like to consider is the superconformal index. As in the case of the BPS partition function, the superconformal index has the information of the BPS spectrum of the theory. Unlike the BPS partition function, the superconformal index includes contributions from scalar, fermion, gauge field, and their descendant operators, as well as chiral primary scalar operators. Thus the superconformal index has richer information than the BPS partition function.

As we have seen in Sec. 1.5, the superconformal index is defined as the Witten index regarding the  $\mathcal{N} = 4$  superconformal algebra on  $\mathbb{R} \times S^3$ . The algebra among fermionic generators are given by

$$\{\bar{Q}_I^{\dot{\alpha}}, Q_\alpha^J\} = \delta_I^J P^{\dot{\alpha}}{}_\beta, \quad (2.51a)$$

$$\{S_I^\alpha, \bar{S}_\beta^J\} = \delta_I^J K^\alpha{}_{\dot{\beta}}, \quad (2.51b)$$

$$\{S_I^\alpha, Q_\beta^J\} = \frac{1}{2} \delta_\beta^\alpha \delta_I^J H + \delta_I^J J^\alpha{}_\beta + \delta_\beta^\alpha \left( R^J{}_I - \frac{1}{4} \delta_I^J R^K{}_K \right), \quad (2.51c)$$

$$\{\bar{Q}_I^{\dot{\alpha}}, \bar{S}_\beta^J\} = \frac{1}{2} \delta_\beta^{\dot{\alpha}} \delta_I^J H - \delta_I^J \bar{J}^{\dot{\alpha}}{}_{\dot{\beta}} - \delta_\beta^{\dot{\alpha}} \left( R^J{}_I - \frac{1}{4} \delta_I^J R^K{}_K \right). \quad (2.51d)$$

Now the superconformal index  $\mathcal{I}$  of the  $\mathcal{N} = 4$  SYM on  $\mathbb{R} \times S^3$  is defined as

$$\mathcal{I} = \text{tr}[(-1)^F \bar{x}^{\bar{\Delta}} q^{H+j_R} y^{2j_L} u^{R_X-R_Y} v^{R_Y-R_Z}], \quad (2.52)$$

where  $\bar{\Delta}$  is given by

$$\bar{\Delta} = 2\{\bar{S}_1^1, \bar{Q}_1^1\} = H - 2j_R - (R_X + R_Y + R_Z). \quad (2.53)$$

The trace is taken over the Hilbert space of the theory on  $\mathbb{R} \times S^3$ . Here  $H$  is the Hamiltonian in the radial quantization, and we defined  $j_L = -J^2_2$  and  $j_R = \bar{J}^1_1$ . The  $SO(6)_R$  generators  $R_X$ ,  $R_Y$ , and  $R_Z$  are defined in (2.1). The BPS condition of an operator  $\mathcal{O}$  for the superconformal index (2.52) is

$$[\bar{Q}_1^1, \mathcal{O}] = [\bar{S}_1^1, \mathcal{O}] = 0. \quad (2.54)$$

This condition is equivalent to the condition  $\bar{\Delta} = 0$ , and the index (2.52) does not depend on  $\bar{x}$ .

It is convenient to expand the index (2.52) with respect to the fugacity  $q$ . Then, we can classify the BPS operators in order from the operator having the smallest conformal dimension. In this case, the index respects the left-handed spin symmetry  $SU(2)_{j_L}$  and part of  $SO(6)_R$ . Since we choose a supercharge  $\bar{Q}_1^1$  to define the index (2.52),  $SO(6)_R$  is broken to  $SU(3)_R \times U(1)$ . This  $SU(3)_R$  is generated by  $R_X - R_Y$  and  $R_Y - R_Z$ , while this  $U(1)$  is generated by  $R_X + R_Y + R_Z$ . The supercharge  $\bar{Q}_1^1$  has a non-trivial charge under this  $U(1)$  (see Table 2.1), so the index only respects this  $SU(3)_R$  symmetry. As a result, the index expanded by  $q$  can be written in terms of the  $SU(3)_R$  character and the  $SU(2)_{j_L}$  character. The  $SU(3)$  character is defined in (A.34), and we define  $SU(2)_{j_L}$  character as

$$\chi_n^J = \chi_n(y), \quad (2.55)$$

where  $\chi_n(a)$  is defined in (A.33).

It seems that the BPS condition (2.54) is different from what we used for the BPS partition function (2.29). In the case of the BPS partition function, since we only consider the chiral primary operators, the condition  $[\bar{S}_1^1, \mathcal{O}] = 0$  is automatically satisfied. Thus, the chiral primary operators that we have considered in the previous subsection satisfy the BPS condition (2.54), and they also contribute to the index (2.52).

Let us calculate the index (2.52) for the  $\mathcal{N} = 4$   $U(N)$  SYM following the procedure given in subsection 1.5.2. To do it, our task is to find the single-particle index of this theory, and we need the list of all fields and equations of motion with charges of  $U(1)_H \times SU(2)_{j_L} \times SU(2)_{j_R} \times SO(6)_R$ . We show this list in Table 2.5 and Table 2.6, and we use the notation  $[j_L, j_R]_E^{(R_X, R_Y, R_Z)}$ , where  $E$  is the conformal dimension (eigenvalue of  $H$ ).

Fields	$[j_L, j_R]_E^{(R_X, R_Y, R_Z)}$	$\bar{\Delta}$
X	$[0, 0]_1^{(1,0,0)}$	0
Y	$[0, 0]_1^{(0,1,0)}$	0
Z	$[0, 0]_1^{(0,0,1)}$	0
$\bar{X}$	$[0, 0]_1^{(-1,0,0)}$	2
$\bar{Y}$	$[0, 0]_1^{(0,-1,0)}$	2
$\bar{Z}$	$[0, 0]_1^{(0,0,-1)}$	2
$\lambda_{11}$	$[\frac{1}{2}, 0]_{\frac{3}{2}}^{(\frac{1}{2}, \frac{1}{2}, \frac{1}{2})}$	0
$\lambda_{12}$	$[-\frac{1}{2}, 0]_{\frac{3}{2}}^{(\frac{1}{2}, \frac{1}{2}, \frac{1}{2})}$	0
$\lambda_{21}$	$[\frac{1}{2}, 0]_{\frac{3}{2}}^{(\frac{1}{2}, -\frac{1}{2}, -\frac{1}{2})}$	2
$\lambda_{22}$	$[-\frac{1}{2}, 0]_{\frac{3}{2}}^{(\frac{1}{2}, -\frac{1}{2}, -\frac{1}{2})}$	2
$\lambda_{31}$	$[\frac{1}{2}, 0]_{\frac{3}{2}}^{(-\frac{1}{2}, \frac{1}{2}, -\frac{1}{2})}$	2
$\lambda_{32}$	$[-\frac{1}{2}, 0]_{\frac{3}{2}}^{(-\frac{1}{2}, \frac{1}{2}, -\frac{1}{2})}$	2
$\lambda_{41}$	$[\frac{1}{2}, 0]_{\frac{3}{2}}^{(-\frac{1}{2}, -\frac{1}{2}, \frac{1}{2})}$	2
$\lambda_{42}$	$[-\frac{1}{2}, 0]_{\frac{3}{2}}^{(-\frac{1}{2}, -\frac{1}{2}, \frac{1}{2})}$	2
$\bar{\lambda}_4^{41}$	$[0, \frac{1}{2}]_{\frac{3}{2}}^{(\frac{1}{2}, \frac{1}{2}, -\frac{1}{2})}$	0
$\bar{\lambda}^{42}$	$[0, -\frac{1}{2}]_{\frac{3}{2}}^{(\frac{1}{2}, \frac{1}{2}, -\frac{1}{2})}$	2
$\bar{\lambda}^{31}$	$[0, \frac{1}{2}]_{\frac{3}{2}}^{(\frac{1}{2}, -\frac{1}{2}, \frac{1}{2})}$	0
$\bar{\lambda}^{32}$	$[0, -\frac{1}{2}]_{\frac{3}{2}}^{(\frac{1}{2}, -\frac{1}{2}, \frac{1}{2})}$	2
$\bar{\lambda}^{21}$	$[0, \frac{1}{2}]_{\frac{3}{2}}^{(-\frac{1}{2}, \frac{1}{2}, \frac{1}{2})}$	0
$\bar{\lambda}^{22}$	$[0, -\frac{1}{2}]_{\frac{3}{2}}^{(-\frac{1}{2}, \frac{1}{2}, \frac{1}{2})}$	2
$\bar{\lambda}^{11}$	$[0, \frac{1}{2}]_{\frac{3}{2}}^{(-\frac{1}{2}, -\frac{1}{2}, -\frac{1}{2})}$	2
$\bar{\lambda}^{12}$	$[0, -\frac{1}{2}]_{\frac{3}{2}}^{(-\frac{1}{2}, -\frac{1}{2}, -\frac{1}{2})}$	4
$F_{11}$	$[1, 0]_2^{(0,0,0)}$	2
$F_{12}$	$[0, 0]_2^{(0,0,0)}$	2
$F_{22}$	$[-1, 0]_2^{(0,0,0)}$	2
$\bar{F}^{i1}$	$[0, 1]_2^{(0,0,0)}$	0
$\bar{F}^{i2}$	$[0, 0]_2^{(0,0,0)}$	2
$\bar{F}^{\dot{2}2}$	$[0, -1]_2^{(0,0,0)}$	4
$\partial_{11}$	$[\frac{1}{2}, \frac{1}{2}]_1^{(0,0,0)}$	0
$\partial_{12}$	$[\frac{1}{2}, -\frac{1}{2}]_1^{(0,0,0)}$	2
$\partial_{2i}$	$[-\frac{1}{2}, \frac{1}{2}]_1^{(0,0,0)}$	0
$\partial_{2\dot{2}}$	$[-\frac{1}{2}, -\frac{1}{2}]_1^{(0,0,0)}$	2

Table 2.5 Charges for fields in  $\mathcal{N} = 4$  SYM.

EOM	$[j_L, j_R]_E^{(R_X, R_Y, R_Z)}$	$\bar{\Delta}$
$\partial^2 X = 0$	$[0, 0, 0]_3^{(1,0,0)}$	2
$\partial^2 Y = 0$	$[0, 0, 0]_3^{(0,1,0)}$	2
$\partial^2 Z = 0$	$[0, 0, 0]_3^{(0,0,1)}$	2
$\partial^2 \bar{X} = 0$	$[0, 0, 0]_3^{(-1,0,0)}$	4
$\partial^2 \bar{Y} = 0$	$[0, 0, 0]_3^{(0,-1,0)}$	4
$\partial^2 \bar{Z} = 0$	$[0, 0, 0]_3^{(0,0,-1)}$	4
$(\partial\lambda)^{11} = 0$	$[0, \frac{1}{2}]_{\frac{5}{2}}^{(\frac{1}{2}, \frac{1}{2}, \frac{1}{2})}$	0
$(\partial\lambda)^{12} = 0$	$[0, -\frac{1}{2}]_{\frac{5}{2}}^{(\frac{1}{2}, \frac{1}{2}, \frac{1}{2})}$	2
$(\partial\lambda)^{21} = 0$	$[0, \frac{1}{2}]_{\frac{5}{2}}^{(\frac{1}{2}, -\frac{1}{2}, -\frac{1}{2})}$	2
$(\partial\lambda)^{22} = 0$	$[0, -\frac{1}{2}]_{\frac{5}{2}}^{(\frac{1}{2}, -\frac{1}{2}, -\frac{1}{2})}$	4
$(\partial\lambda)^{31} = 0$	$[0, \frac{1}{2}]_{\frac{5}{2}}^{(-\frac{1}{2}, \frac{1}{2}, -\frac{1}{2})}$	2
$(\partial\lambda)^{32} = 0$	$[0, -\frac{1}{2}]_{\frac{5}{2}}^{(-\frac{1}{2}, \frac{1}{2}, -\frac{1}{2})}$	4
$(\partial\lambda)^{41} = 0$	$[0, \frac{1}{2}]_{\frac{5}{2}}^{(-\frac{1}{2}, -\frac{1}{2}, \frac{1}{2})}$	2
$(\partial\lambda)^{42} = 0$	$[0, -\frac{1}{2}]_{\frac{5}{2}}^{(-\frac{1}{2}, -\frac{1}{2}, \frac{1}{2})}$	4
$(\partial\bar{\lambda})_{41} = 0$	$[\frac{1}{2}, 0]_{\frac{5}{2}}^{(\frac{1}{2}, \frac{1}{2}, -\frac{1}{2})}$	2
$(\partial\bar{\lambda})_{42} = 0$	$[-\frac{1}{2}, 0]_{\frac{5}{2}}^{(\frac{1}{2}, \frac{1}{2}, -\frac{1}{2})}$	2
$(\partial\bar{\lambda})_{31} = 0$	$[\frac{1}{2}, 0]_{\frac{5}{2}}^{(\frac{1}{2}, -\frac{1}{2}, \frac{1}{2})}$	2
$(\partial\bar{\lambda})_{32} = 0$	$[-\frac{1}{2}, 0]_{\frac{5}{2}}^{(\frac{1}{2}, -\frac{1}{2}, \frac{1}{2})}$	2
$(\partial\bar{\lambda})_{21} = 0$	$[\frac{1}{2}, 0]_{\frac{5}{2}}^{(-\frac{1}{2}, \frac{1}{2}, \frac{1}{2})}$	2
$(\partial\bar{\lambda})_{22} = 0$	$[-\frac{1}{2}, 0]_{\frac{5}{2}}^{(-\frac{1}{2}, \frac{1}{2}, \frac{1}{2})}$	2
$(\partial\bar{\lambda})_{11} = 0$	$[\frac{1}{2}, 0]_{\frac{5}{2}}^{(-\frac{1}{2}, -\frac{1}{2}, -\frac{1}{2})}$	4
$(\partial\bar{\lambda})_{12} = 0$	$[-\frac{1}{2}, 0]_{\frac{5}{2}}^{(-\frac{1}{2}, -\frac{1}{2}, -\frac{1}{2})}$	4
$(\partial F)_1^1 = 0$	$[\frac{1}{2}, \frac{1}{2}]_3^{(0,0,0)}$	2
$(\partial F)_2^1 = 0$	$[\frac{1}{2}, -\frac{1}{2}]_3^{(0,0,0)}$	4
$(\partial F)_4^2 = 0$	$[-\frac{1}{2}, \frac{1}{2}]_3^{(0,0,0)}$	2
$(\partial F)_2^2 = 0$	$[-\frac{1}{2}, -\frac{1}{2}]_3^{(0,0,0)}$	4
$(\partial\bar{F})_1^1 = 0$	$[\frac{1}{2}, \frac{1}{2}]_3^{(0,0,0)}$	2
$(\partial\bar{F})_2^1 = 0$	$[\frac{1}{2}, -\frac{1}{2}]_3^{(0,0,0)}$	4
$(\partial\bar{F})_1^2 = 0$	$[-\frac{1}{2}, \frac{1}{2}]_3^{(0,0,0)}$	2
$(\partial\bar{F})_2^2 = 0$	$[-\frac{1}{2}, -\frac{1}{2}]_3^{(0,0,0)}$	4
$\partial_{[\alpha}^{\gamma} \partial_{\beta]}^{\epsilon} F_{\gamma\epsilon} \equiv 0$	$[0, 0]_4^{(0,0,0)}$	4
$\partial_{\dot{\gamma}}^{[\alpha} \partial_{\dot{\epsilon}]}^{\beta]} \bar{F}^{\dot{\gamma}\dot{\epsilon}} \equiv 0$	$[0, 0]_4^{(0,0,0)}$	4

Table 2.6 Charges for equations of motion (EOM) in  $\mathcal{N} = 4$  SYM.

Now we pick up the BPS fields with  $\bar{\Delta} = 0$  to calculate the single-particle index. Other contributions are automatically canceled due to the boson-fermion cancellation. We should also include the descendants generated by  $\partial_{1i}$  and  $\partial_{2i}$  because these derivatives satisfy the BPS condition. Let  $m(q, y, u, v)$  be a monomial corresponding to the contribution of a certain BPS primary operator  $\mathcal{O}_{\text{BPS}}$ . Its descendants are obtained by multiplying the derivatives repeatedly. For example, if a descendant has  $k$   $\partial_{1i}$ 's and  $l$   $\partial_{2i}$ 's, this descendant field is  $(\partial_{1i})^k (\partial_{2i})^l \mathcal{O}_{\text{BPS}}$ . Since the monomials corresponding to the derivatives  $\partial_{1i}$  and  $\partial_{2i}$  are  $q^{\frac{3}{2}}y$  and  $q^{\frac{3}{2}}y^{-1}$  respectively, the monomial corresponding to this descendant field is given by  $(q^{\frac{3}{2}}y)^k (q^{\frac{3}{2}}y^{-1})^l m(q, y, u, v)$ . Therefore, all the contributions from the primary field and descendant fields becomes

$$\sum_{k,l=0}^{\infty} (q^{\frac{3}{2}}y)^k (q^{\frac{3}{2}}y^{-1})^l m(q, y, u, v) = \frac{m(q, y, u, v)}{(1 - q^{\frac{3}{2}}y)(1 - q^{\frac{3}{2}}y^{-1})}. \quad (2.56)$$

Gathering all the BPS contributions, including their descendants, gives the following formula for the single-particle index:

$$i_{\text{sp}} = \frac{\chi_{(1,0)}q - \chi_1^J q^{\frac{3}{2}} - \chi_{(0,1)}q^2 + 2q^3}{(1 - q^{\frac{3}{2}}y)(1 - q^{\frac{3}{2}}y^{-1})}, \quad (2.57)$$

where  $\chi_{(m,n)}$  and  $\chi_n^J$  are the  $SU(3)_R$  character and  $SU(2)_{j_L}$  character defined by (A.34) and (2.55), respectively.

According to the formula (1.84), the superconformal index of the  $\mathcal{N} = 4$   $U(N)$  SYM is now given by

$$\mathcal{I}_{U(N)} = \int_{U(N)} d\mu \text{Pexp}(i_{\text{sp}} \chi_{\text{adj}}^{U(N)}), \quad (2.58)$$

where  $i_{\text{sp}}$  is defined in (2.57). The Haar measure is given by (2.32b) and  $\chi_{\text{adj}}^{U(N)}$  is given by (2.32c). Note that this formula is valid even for the interacting theory because the index does not depend on the coupling constant. The indices for small ranks up to some orders of  $q$  are given by

$$\begin{aligned} \mathcal{I}_{U(1)} = & 1 + \chi_{(1,0)}q - \chi_1^J q^{\frac{3}{2}} + (\chi_{(2,0)} - \chi_{(0,1)})q^2 + (\chi_{(3,0)} - \chi_{(1,1)} + 1 - \chi_2^J)q^3 \\ & + \chi_1^J \chi_{(0,1)}q^{\frac{7}{2}} + (\chi_{(4,0)} - \chi_{(2,1)} + \chi_{(1,0)} - \chi_2^J \chi_{(1,0)})q^4 \\ & + (\chi_2^J \chi_{(0,1)} + \chi_{(2,0)} - \chi_{(3,1)} + \chi_{(5,0)})q^5 + (-\chi_1^J \chi_{(1,0)} - \chi_3^J \chi_{(1,0)})q^{\frac{11}{2}} \\ & + (\chi_2^J \chi_{(1,1)} + \chi_{(3,0)} - \chi_{(4,1)} + \chi_{(6,0)})q^6 + \mathcal{O}(q^{\frac{13}{2}}), \end{aligned} \quad (2.59)$$

$$\begin{aligned}
\mathcal{I}_{U(2)} = & 1 + \chi_{(1,0)} q - \chi_1^J q^{\frac{3}{2}} + (-\chi_{(0,1)} + 2\chi_{(2,0)}) q^2 - \chi_1^J \chi_{(1,0)} q^{\frac{5}{2}} \\
& + (2 - \chi_2^J - \chi_{(1,1)} + 2\chi_{(3,0)}) q^3 + \chi_1^J (\chi_{(0,1)} - \chi_{(2,0)}) q^{\frac{7}{2}} \\
& + (-\chi_2^J \chi_{(1,0)} + \chi_{(1,0)} - 2\chi_{(2,1)} + 3\chi_{(4,0)}) q^4 + \chi_1^J (1 + 2\chi_{(1,1)} - \chi_{(3,0)}) q^{\frac{9}{2}} \\
& + (-2\chi_2^J \chi_{(2,0)} - 2\chi_{(0,1)} + \chi_{(2,0)} - 2\chi_{(3,1)} + 3\chi_{(5,0)}) q^5 \\
& + \chi_1^J (\chi_{(1,0)} + 2\chi_{(2,1)} - \chi_{(4,0)}) q^{\frac{11}{2}} \\
& + (\chi_2^J (\chi_{(1,1)} - \chi_{(3,0)}) - \chi_{(1,1)} + 2\chi_{(3,0)} - 3\chi_{(4,1)} + 4\chi_{(6,0)}) q^6 \\
& + (-\chi_3^J \chi_{(2,1)} + \chi_1^J (-3\chi_{(0,1)} - \chi_{(1,2)} + 2\chi_{(3,1)} - \chi_{(5,0)})) q^{\frac{13}{2}} \\
& + (\chi_2^J (3\chi_{(0,2)} + 2\chi_{(1,0)} + 2\chi_{(2,1)} - 2\chi_{(4,0)}) + 4\chi_{(1,0)} + 2\chi_{(4,0)} \\
& \quad - 3\chi_{(5,1)} + 4\chi_{(7,0)}) q^7 \\
& + (\chi_5^J + \chi_3^J (-1 - 2\chi_{(1,1)} - \chi_{(3,0)}) + \chi_1^J (-1 - 5\chi_{(1,1)} \\
& \quad - \chi_{(2,2)} - 2\chi_{(3,0)} + 2\chi_{(4,1)} - \chi_{(6,0)})) q^{\frac{15}{2}} \\
& + (\chi_4^J (\chi_{(0,1)} - \chi_{(2,0)}) + \chi_2^J (\chi_{(1,2)} + 4\chi_{(2,0)} + 3\chi_{(3,1)} - 2\chi_{(5,0)}) \\
& \quad + 3\chi_{(0,1)} + \chi_{(1,2)} + \chi_{(2,0)} + 3\chi_{(5,0)} - 4\chi_{(6,1)} + 5\chi_{(8,0)}) q^8 + \mathcal{O}(q^{\frac{17}{2}}), \quad (2.60)
\end{aligned}$$

$$\begin{aligned}
\mathcal{I}_{U(3)} = & 1 + \chi_{(1,0)} q - \chi_1^J q^{\frac{3}{2}} + (-\chi_{(0,1)} + 2\chi_{(2,0)}) q^2 - \chi_1^J \chi_{(1,0)} q^{\frac{5}{2}} \\
& + (2 - \chi_2^J - \chi_{(1,1)} + 3\chi_{(3,0)}) q^3 + \chi_1^J (\chi_{(0,1)} - 2\chi_{(2,0)}) q^{\frac{7}{2}} \\
& + (-\chi_2^J \chi_{(1,0)} + \chi_{(0,2)} + 2\chi_{(1,0)} - 2\chi_{(2,1)} + 4\chi_{(4,0)}) q^4 \\
& + \chi_1^J (1 + \chi_{(1,1)} - 2\chi_{(3,0)}) q^{\frac{9}{2}} \\
& + (\chi_2^J (\chi_{(0,1)} - 2\chi_{(2,0)}) - 2\chi_{(0,1)} + 2\chi_{(2,0)} - 2\chi_{(3,1)} + 5\chi_{(5,0)}) q^5 \\
& + \chi_1^J (\chi_{(1,0)} + 3\chi_{(2,1)} - 3\chi_{(4,0)}) q^{\frac{11}{2}} \\
& + (-\chi_{(0,3)} - 4\chi_{(1,1)} + \chi_{(2,2)} + 3\chi_{(3,0)} - 3\chi_2^J \chi_{(3,0)} - 4\chi_{(4,1)} + 7\chi_{(6,0)}) q^6 \\
& + \chi_1^J (\chi_{(0,1)} + \chi_{(1,2)} + 3\chi_{(2,0)} + 3\chi_{(3,1)} - 3\chi_{(5,0)}) q^{\frac{13}{2}} \\
& + (\chi_2^J (-\chi_{(0,2)} - \chi_{(1,0)} + \chi_{(2,1)} - 4\chi_{(4,0)}) - \chi_{(0,2)} + \chi_{(1,0)} - 5\chi_{(2,1)} \\
& \quad + 3\chi_{(4,0)} - 4\chi_{(5,1)} + 8\chi_{(7,0)}) q^7 \\
& + (\chi_5^J - \chi_3^J \chi_{(3,0)} + \chi_1^J (1 - \chi_{(1,1)} + 3\chi_{(3,0)} + 5\chi_{(4,1)} - 4\chi_{(6,0)})) q^{\frac{15}{2}} \\
& + (\chi_2^J (\chi_{(0,1)} + 2\chi_{(1,2)} + 2\chi_{(2,0)} + \chi_{(3,1)} - 5\chi_{(5,0)}) + 3\chi_{(0,1)} + \chi_{(0,4)} \\
& \quad + \chi_{(1,2)} + \chi_{(2,0)} - \chi_{(2,3)} - 5\chi_{(3,1)} + \chi_{(4,2)} + 4\chi_{(5,0)} - 6\chi_{(6,1)} + 10\chi_{(8,0)}) q^8 \\
& + (\chi_1^J (-4\chi_{(0,2)} - 5\chi_{(1,0)} - \chi_{(1,3)} - 6\chi_{(2,1)} + 3\chi_{(4,0)} + 5\chi_{(5,1)} - 4\chi_{(7,0)}) \\
& \quad + \chi_3^J (-3\chi_{(0,2)} - \chi_{(1,0)} - \chi_{(2,1)} - \chi_{(4,0)}) + \chi_5^J \chi_{(1,0)}) q^{\frac{17}{2}} \\
& + (3\chi_{(0,3)} + 8\chi_{(1,1)} + 2\chi_{(2,2)} + 6\chi_{(3,0)} - 5\chi_{(4,1)} + 5\chi_{(6,0)} - 7\chi_{(7,1)} + 12\chi_{(9,0)} \\
& \quad + \chi_2^J (6 + \chi_{(0,3)} + 8\chi_{(1,1)} + 3\chi_{(2,2)} + 4\chi_{(3,0)} + 3\chi_{(4,1)} - 6\chi_{(6,0)}) \\
& \quad + \chi_4^J (\chi_{(1,1)} - \chi_{(3,0)} - 1)) q^9 \\
& + (\chi_1^J (-8\chi_{(0,1)} - 8\chi_{(1,2)} - 8\chi_{(2,0)} - \chi_{(2,3)} - 10\chi_{(3,1)} - \chi_{(4,2)} + \chi_{(5,0)} + 7\chi_{(6,1)} - 5\chi_{(8,0)}) \\
& \quad + \chi_3^J (-4\chi_{(0,1)} - 2\chi_{(1,2)} - 2\chi_{(2,0)} - 2\chi_{(3,1)} - 2\chi_{(5,0)}) + \chi_5^J (-\chi_{(0,1)} + 2\chi_{(2,0)})) q^{\frac{19}{2}} \\
& + (-4\chi_{(0,2)} - \chi_{(0,5)} + 3\chi_{(1,0)} + 2\chi_{(1,3)} + 12\chi_{(2,1)} + \chi_{(2,4)} + 3\chi_{(3,2)} + 6\chi_{(4,0)} - \chi_{(4,3)} \\
& \quad - 5\chi_{(5,1)} + \chi_{(6,2)} + 6\chi_{(7,0)} - 9\chi_{(8,1)} + 14\chi_{(10,0)} \\
& \quad + \chi_2^J (2\chi_{(0,2)} + 4\chi_{(1,0)} + 7\chi_{(2,1)} + 5\chi_{(3,2)} + 7\chi_{(4,1)} + 4\chi_{(5,1)} - 7\chi_{(7,0)}) \\
& \quad + \chi_4^J (-\chi_{(0,2)} + \chi_{(1,0)} - \chi_{(4,0)}) q^{10} + \mathcal{O}(q^{\frac{21}{2}}). \tag{2.61}
\end{aligned}$$

In the next chapter, we will reproduce these results up to certain orders of the fugacity  $q$  from the AdS side. Before going to this reproduction, we will review the essential concepts of type IIB string theory in the next section.

## 2.2 Type IIB string theory

The superstring theory is a theory of strings that propagate in ten-dimensional (10d) spacetime. It is well known that there are five different anomaly free superstring theories: type I, type IIA, type IIB, Heterotic  $SO(32)$ , and Heterotic  $E_8 \times E_8$ . These string theories

are related to each other by the string duality. In this section, we review type IIB theories, which has  $\mathcal{N} = (2, 0)$  supersymmetry, because our interest in this thesis is the AdS/CFT correspondence regarding type IIB string theory.

There are two kinds of strings: closed strings and open strings. In the 10d spacetime, a string sweeps a two-dimensional (2d) surface  $\Sigma$  called a worldsheet. Let  $\sigma^a$  ( $a = 0, 1$ ) be the coordinates on the worldsheet, where  $\sigma^0$  and  $\sigma^1$  stand for the temporal and spatial coordinates, respectively. We normalize  $\sigma^1$  so that  $\sigma^1 \in [0, \pi]$ . Then the motion of strings is described in the 10d coordinates  $X^M(\sigma)$  ( $M = 0, 1, \dots, 9$ ), a map from the 2d worldsheet into the 10d spacetime called the target space. There are also fermionic partners of  $X^M$ , denoted by  $\psi^M(\sigma)$ , which is a two-component Dirac spinor in 2d.

The bosonic part of the string action is the Polyakov action given by

$$S_{\text{str}} = -\frac{1}{4\pi\ell_s^2} \int_{\Sigma} d^2\sigma \sqrt{-g} g^{ab}(\sigma) \partial_a X^M \partial_b X_M, \quad (2.62)$$

where  $g^{ab}(\sigma)$  is a metric on the worldsheet.  $\ell_s$  is called the string length, a unique parameter of the string theory.

The general solution of the equation of motion obtained from (2.62) is a superposition of left- and right-moving waves

$$X^M(\sigma) = X_L^M(\sigma^1 + \sigma^0) + X_R^M(\sigma^1 - \sigma^0). \quad (2.63)$$

The corresponding fermionic partners to the left- and right-moving waves are the lower and upper component of  $\psi^M(\sigma)$ . Then we denote  $\psi^M(\sigma)$  as

$$\psi^M(\sigma) = \begin{pmatrix} \psi_R^M(\sigma^1 - \sigma^0) \\ \psi_L^M(\sigma^1 + \sigma^0) \end{pmatrix}. \quad (2.64)$$

Although we omitted the fermionic part of the action in (2.62), we can find the coordinate dependence of  $\psi_{L,R}^M$  by using the equation of motion of the fermionic fields. We refer to  $(X_{L/R}^M, \psi_{L/R}^M)$  as the left/right moving sector.

### 2.2.1 Closed strings

Let us first consider the closed strings. Since the discussion of the right moving sector is parallel to that of the left moving sector, we focus on the left moving sector.

Here we discuss the boundary condition of fields. For the bosonic field  $X_L^M$ , the periodicity of the closed string means  $X_L^M(\sigma^1 + \sigma^0 + \pi) = X_L^M(\sigma^1 + \sigma^0)$ . On the other hand, there are two choices of the boundary condition for the fermionic field  $\psi_L^M$ : the periodic

Sectors	Fields
NS-NS	$\phi, B_{MN}, g_{MN}$
NS-R	$\lambda_L^M, \chi_R$
R-NS	$\lambda_L^M, \chi_R$
R-R	$C, C_{MN}, C_{MNRS}$

Table 2.7 The massless spectrum of the type IIB theory. The NS-NS and R-R sectors are made of bosonic fields, whereas NS-R and R-NS sectors are made of fermionic fields.

and anti-periodic boundary conditions

$$\text{Ramond (R)} : \psi_L^M(\sigma^1 + \sigma^0 + \pi) = \psi_L^M(\sigma^1 + \sigma^0), \quad (2.65a)$$

$$\text{Neveu-Schwarz (NS)} : \psi_L^M(\sigma^1 + \sigma^0 + \pi) = -\psi_L^M(\sigma^1 + \sigma^0). \quad (2.65b)$$

Fermionic fields satisfying (2.65a) are called Ramond (R) fermions, and fermionic fields satisfying (2.65b) are called Neveu-Schwarz (NS) fermions.

Now we can do the oscillator expansion for the bosonic field  $X_L^M$  and the fermionic field  $\psi_L^M$ . If we impose the canonical commutation relations for the coefficients of the oscillator expansion, we can perform the quantization of the theory. Then, we obtain the finite number of massless states and the infinite number of massive states. However, we are interested in the low energy behavior of the string theory, so we focus on the massless states here. Combining the left moving sector and the right moving sector, we have four sectors depending on the choice of the boundary condition of the fermionic fields: NS-NS, NS-R, R-NS, and R-R sector. The NS-NS and R-R sectors have the 10d bosonic fields, and NS-R and R-NS sectors have 10d fermionic fields. The massless fields of type IIB string theory appearing in these sectors are summarized in Table 2.7.

We can find many massless fields in Table 2.7. In the NS-NS sector, we have a scalar field  $\phi$  called the dilaton, 2-form field  $B_{MN}$  called “B-field”, and symmetric tensor field  $g_{MN}$  called graviton. In the NS-R and R-NS sectors, we have two left-handed gravitinos  $\lambda_L^M$  and two right-handed dilatinos  $\chi_R$ . The existence of two gravitinos belonging to the same chirality shows that the theory indeed has the  $\mathcal{N} = (2, 0)$  supersymmetry. In the R-R sector, we have  $p$ -form fields with  $p = 0, 2, 4$ , and they are called R-R  $p$ -form fields.

### 2.2.2 Open strings

So far, we have reviewed the massless spectrum of closed strings. There are also open strings as well as closed strings. For open strings, there are two kinds of boundary conditions: Dirichlet and Neumann boundary conditions. For bosonic fields, these boundary

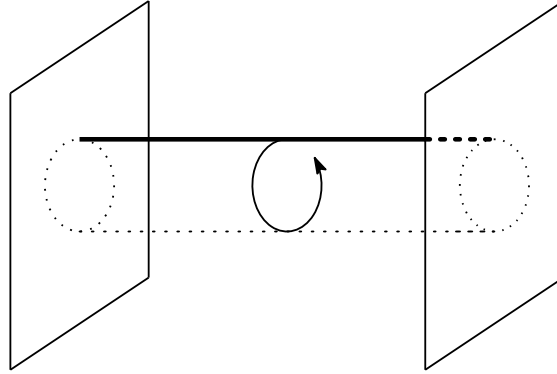

Fig. 2.1 An open string connecting a D-brane with the other D-brane. Its worldsheet is a cylinder.

conditions are expressed as

$$X^M \Big|_{\sigma^1=0,\pi} = \text{const.} : \text{Dirichlet boundary conditions}, \quad (2.66)$$

$$\frac{\partial X^M}{\partial \sigma^1} \Big|_{\sigma^1=0,\pi} = 0 : \text{Neumann boundary conditions}. \quad (2.67)$$

We can choose different boundary conditions for each  $M$ . When the Dirichlet boundary condition is imposed on the  $9 - p$  bosonic fields, endpoints of strings can move in a  $p + 1$ -dimensional hypersurface called a  $Dp$ -brane. This hypersurface is specified by the equations (2.66).

The spectrum of open strings is also obtained by the canonical quantization. We can also consider NS and R fermions. The quantization gives us the finite number of massless states and the infinite number of massive states. Again, we are interested in the massless states, and it is convenient to regard the massless fields as fields living on  $Dp$ -branes. Namely, we can realize a  $p + 1$ -dimensional quantum field theory on  $Dp$ -branes in the low-energy limit. In this sense, D-branes are useful to investigate quantum field theories. So, in what follows, we will see the properties of  $Dp$ -branes.

### 2.2.3 D-branes

In the last subsection, we defined a  $Dp$ -brane as a  $p + 1$ -dimensional hypersurface where open strings can end. However, D-branes have various properties as physical objects that go beyond just the hypersurface.

#### Coupling to R-R fields

In fact, D-branes are electrically coupled to R-R fields [31]. This fact can be understood through the open-closed duality in the string theory. Suppose a situation where two flat D-branes are placed with a certain distance, as in Fig. 2.1. Then an open string can be stretched between two D-branes. The shape of the worldsheet of this open string is

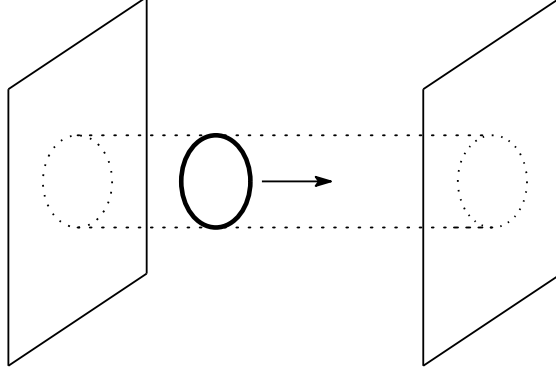

Fig. 2.2 A closed string propagating between two D-branes. Its worldsheet is also a cylinder. We can regard this situation as the radiation and absorption of a closed string by D-branes.

a cylinder connecting a D-brane with the other one. However, this situation can also be regarded as a propagation of a closed string between two D-branes, as in Fig. 2.2. In this sense, we can say that D-branes are the source of closed strings. Then we have an electric coupling term of a single D $p$ -brane to the R-R  $p+1$ -form field  $C_{p+1}$  as well as the kinetic term of the R-R field as follows:

$$S_{\text{RR}} = -\frac{1}{2g_e^2} \int F_{p+2} \wedge *F_{p+2} - \int_{\text{wv}} C_{p+1}, \quad (2.68)$$

where the integral of the coupling term is taken over the  $p+1$ -dimensional worldvolume of a D $p$ -brane. Note that  $p$  takes the values  $-1, 1, 3$  for type IIB string theory<sup>\*2</sup>.  $F_{p+2} = dC_{p+1}$  is the field strength of the R-R field. The Hodge dual  $*$  of a  $k$ -form field  $A_k$  is defined by

$$\begin{aligned} *A_k &= * \left( \frac{1}{k!} A_{M_1 \dots M_k} dX^{M_1} \wedge \dots \wedge dX^{M_k} \right) \\ &= \frac{1}{k!(10-k)!} \epsilon_{M_1 \dots M_k N_1 \dots N_{10-k}} A^{M_1 \dots M_k} dX^{N_1} \wedge \dots \wedge dX^{N_{10-k}}. \end{aligned} \quad (2.69)$$

$g_e$  is the unit charge of a single D $p$ -brane defined by

$$g_e = (2\pi\ell_s)^{\frac{7-p}{2}}. \quad (2.70)$$

Then the definition of the electric charge of a single D $p$ -branes should be given by

$$Q_{\text{ele}} = \frac{1}{g_e} \oint_{S^{8-p}} *F_{p+2} = g_e. \quad (2.71)$$

<sup>\*2</sup> Here we do not discuss type IIA string theory in detail,  $p$  can take the values  $0, 2$  in type IIA string theory.

D-branes	electric	magnetic
D(-1)	$C_0$	$\tilde{C}_8$
D1	$C_2$	$\tilde{C}_6$
D3	$C_4$	$C_4$
D5	$\tilde{C}_6$	$C_2$
D7	$\tilde{C}_8$	$C_0$

Table 2.8 A table for R-R  $p+1$ -forms and electrically coupled  $Dp$ -branes.  $Dp$ -branes can also magnetically couple to R-R  $7-p$ -forms.

Therefore, the electric charge of  $Dp$ -branes is the unit charge  $g_e$  times the number of  $Dp$ -branes.

It is possible to consider the magnetic version of above discussion. The magnetic flux  $\tilde{F}_{8-p}$  is defined by the Hodge dual of the electric flux  $F_{p+2}$  as

$$\frac{1}{g_m} \tilde{F}_{8-p} = \frac{1}{g_e} * F_{p+2}, \quad (2.72)$$

where  $g_m$  is the unit magnetic charge of a single  $Dp$ -brane. The unit electric charge  $g_e$  and the unit magnetic charge  $g_m$  satisfy the Dirac quantization condition

$$g_e g_m = 2\pi. \quad (2.73)$$

Then the definition of the magnetic charge of a single  $Dp$ -brane should be given by

$$Q_{\text{mag}} = \frac{1}{g_m} \oint_{S^{p+2}} * \tilde{F}_{8-p} = g_m. \quad (2.74)$$

Using (2.72) and the Dirac quantization condition (2.73), we can show that

$$\oint F_{p+2} \in 2\pi\mathbb{Z}. \quad (2.75)$$

Finally, we can define  $Dp$ -branes with  $p = 5, 7$  as objects magnetically coupled to R-R fields in type IIB string theory. Thus we find  $Dp$ -branes with odd  $p$  in type IIB string theory. They are summarized in Table 2.8. In this Table we defined dual R-R fields  $\tilde{C}_p$  satisfying  $\tilde{F}_{p+1} = d\tilde{C}_p$ .

### $(p, q)$ -string

In addition to the D1-brane, we can consider the electrically charged object for the  $B$ -field. This object is called the fundamental string (F1-string). In this context, we may call the D1-brane the D1-string. Furthermore, we can also consider the one-dimensional object, a bound state of  $p$  F1-strings and  $q$  D1-strings. This object is called  $(p, q)$ -string, where

$(p, q)$  charges are given by

$$p = \int *H_3, \quad q = \int *F_3. \quad (2.76)$$

Here we defined the fluxes  $H_3 = dB_2$  and  $F_3 = dC_2$ .

### Dirac-Born-Infeld action

We have seen that D-branes couple to the R-R fields. Besides this, we can also consider the motion of D-branes. In the case of a relativistic particle, its motion is described by its worldline. Likewise, the motion of D-branes is described by its worldvolume. Thus the action of D-branes is schematically given by

$$S_{Dp} \propto - \int d^p \xi \sqrt{-\det G_{ab}}, \quad (2.77)$$

where  $\xi_a$  ( $a = 0, \dots, p-1$ ) are coordinates on  $Dp$ -branes and  $G_{ab}$  is the induced metric defined by

$$G_{ab} = \frac{\partial X^M}{\partial \xi^a} \frac{\partial X^N}{\partial \xi^b} g_{MN}. \quad (2.78)$$

Here  $X^M(\xi)$  ( $M = 0, \dots, 9$ ) are 10d coordinates having a role of a map from  $p+1$ -dimensional worldvolume to 10d target space and  $g_{MN}$  is the 10d metric.

The existence of the 10d metric  $g_{MN}$  in the induced metric shows that D-branes couple to the graviton in the NS-NS sector. Then it is easy to expect that D-branes couple to not only the graviton but also all fields in the NS-NS sector, namely the dilaton and  $B$ -field. Actually, this is the case.

Besides the NS-NS sector in the bulk, an open string living on a D-brane has a vector field. This vector field is a  $U(1)$  gauge field on the D-brane.

Including all fields coupled to the D-brane, we obtain the correct action for the  $Dp$ -brane called the Dirac-Born-Infeld (DBI) action as follows:

$$S_{Dp}^{\text{DBI}} = - \frac{1}{(2\pi)^p \ell_s^{p+1}} \int d^{p+1} \xi e^{-\phi} \sqrt{-\det(G_{ab} + B_{ab} + 2\pi \ell_s^2 F_{ab})}. \quad (2.79)$$

Because of the supersymmetry, there should also be coupling to the fermionic terms that we omitted here.

The vacuum expectation value of the dilaton  $\phi$  gives the string coupling constant of type II string theories as  $g_s = e^{\langle \phi \rangle}$ . Although it is believed that  $g_s$  should be determined by physics, we have no way to do it up to now because we may need the non-perturbative

formulation of the string theory. Then the tension of a D-brane is given by

$$T_p = \frac{1}{(2\pi)^p \ell_s^{p+1} g_s}. \quad (2.80)$$

In summary, the action of D $p$ -branes is made with the DBI action and the coupling to the R-R fields. In fact, the coupling to the R-R field is generalized to the Chern-Simons (CS) type action

$$S_{\text{D}p}^{\text{CS}} = \int \left[ e^{2\pi\ell_s^2 F_2 + B_2} \wedge \sum_k C_k \right]_{p+1}, \quad (2.81)$$

where  $[ \ ]_{p+1}$  indicates that we pick up only  $p + 1$ -form. The R-R coupling term we have already discussed is included in the first term of the expansion of the exponential. Therefore, the action of a single D $p$ -brane is

$$S_{\text{D}p} = S_{\text{D}p}^{\text{DBI}} + S_{\text{D}p}^{\text{CS}}. \quad (2.82)$$

### 2.2.4 Type IIB supergravity

Finally, let us review type IIB supergravity. This is the low energy effective theory of type IIB string theory and only includes the massless fields in the string theory. The massless fields of type IIB string theory are summarized in Table 2.7. The action of type IIB supergravity is given by

$$\begin{aligned} S_{\text{IIB}}^{\text{SUGRA}} = & \frac{1}{2\kappa^2} \int d^{10}X \sqrt{-G} \left( \mathcal{R} - \frac{1}{2} G^{MN} \frac{\partial_M \tau \partial_N \bar{\tau}}{(\text{Im}\tau)^2} \right) \\ & - \frac{1}{4\kappa^2} \int |\tau|^2 H_3 \wedge *H_3 - \frac{1}{4\kappa^2} \int F_3 \wedge *F_3 \\ & - \frac{1}{4\kappa^2} \int \text{Re}\tau F_3 \wedge *H_3 - \frac{1}{4\kappa^2} \int \text{Re}\tau H_3 \wedge *F_3 \\ & - \frac{1}{4\kappa^2} \int F'_5 \wedge *F'_5 - \frac{1}{4\kappa^2} \int C_4 \wedge H_3 \wedge F_3 + (\text{fermion terms}), \end{aligned} \quad (2.83)$$

where  $\kappa$  is the 10d Newton constant defined by

$$\kappa^2 = \frac{(2\pi)^7 \ell_s^8}{2}. \quad (2.84)$$

$\tau = C_0 + ie^{-\phi}$  is the axio-dilaton field. Fluxes  $H_3$ ,  $F_3$ , and  $F'_5$  are defined as

$$H_3 = dB_2, \quad F_3 = dC_2, \quad F'_5 = dC_4 + \frac{1}{2} B_2 \wedge dC_2 - \frac{1}{2} C_2 \wedge dB_2. \quad (2.85)$$

We rescaled the metric  $g_{MN}$  as

$$G_{MN} = e^{-\phi/2} g_{MN}. \quad (2.86)$$

The action (2.83) is invariant under the following  $SL(2, \mathbb{R})$  transformation

$$\tau \rightarrow \tau' = \frac{a\tau + b}{c\tau + d}, \quad (2.87a)$$

$$\begin{pmatrix} C_2 \\ B_2 \end{pmatrix} \rightarrow \begin{pmatrix} C'_2 \\ B'_2 \end{pmatrix} = M \begin{pmatrix} C_2 \\ B_2 \end{pmatrix}, \quad (2.87b)$$

$$C_4 \rightarrow C'_4 = C_4, \quad (2.87c)$$

$$G_{MN} \rightarrow G'_{MN} = G_{MN}, \quad (2.87d)$$

where

$$M = \begin{pmatrix} a & b \\ c & d \end{pmatrix} \in SL(2, \mathbb{R}). \quad (2.88)$$

Thus type IIB supergravity has the  $SL(2, \mathbb{R})$  symmetry.

Because the 2-form fields form an  $SL(2, \mathbb{R})$  doublet, the  $(p, q)$  charges also form an  $SL(2, \mathbb{R})$  doublet. Then, due to the flux quantization (2.75), the  $SL(2, \mathbb{R})$  symmetry is broken to  $SL(2, \mathbb{Z})$ .

This symmetry maps type IIB string theory with the string coupling constant  $g_s = e^{\langle \phi \rangle}$  onto that with  $1/g_s$ . This can be seen by considering a matrix

$$M = \begin{pmatrix} 0 & -1 \\ 1 & 0 \end{pmatrix} \quad (2.89)$$

with  $C_0 = 0$ . Then the transformation (2.87a) means

$$g_s \rightarrow \frac{1}{g_s}. \quad (2.90)$$

Therefore, type IIB supergravity has a strong/weak self duality called the S-duality. The S-duality holds even for type IIB string theory.

## 2.3 The correspondence

We have finished preparing to discuss the AdS/CFT correspondence between 4d  $\mathcal{N} = 4$  SYM and type IIB string theory on  $AdS_5 \times S^5$ . Here, let us confirm the precise statement of AdS/CFT. The AdS/CFT correspondence states that

— The AdS/CFT correspondence —

4d  $\mathcal{N} = 4$   $U(N)$  supersymmetric Yang-Mills theory with coupling constant  $g_{\text{YM}}$

is equivalent to

type IIB superstring theory with string length  $\ell_s$  and string coupling constant  $g_s$  on  $AdS_5 \times S^5$  whose radius is  $L$ .

Note that the AdS/CFT correspondence is still a conjecture.

There are two free parameters on both sides. On the CFT side, we have the rank of gauge group  $N$  and the coupling constant  $g_{\text{YM}}$ . On the AdS side, we have the string length  $\ell_s$  and the AdS radius  $L$ , which is the typical scale of the AdS system. They are related by the following two independent equations:

$$2g_{\text{YM}}^2 N = \frac{L^4}{\ell_s^4}, \quad (2.91a)$$

$$4\pi N = \frac{L^4}{\ell_{\text{P}}^4}, \quad (2.91b)$$

where  $\ell_{\text{P}}$  is the Planck length defined by  $\ell_{\text{P}}^4 = \ell_s^4 g_s$ . Using this definition of the Planck length, it follows that  $g_{\text{YM}}^2 = 2\pi g_s$  from (2.91). In this duality, all the physics on the CFT side is mapped to the physics on the AdS side, and vice versa.

Let us see the AdS/CFT correspondence in various parameter region using (2.91).

- $g_{\text{YM}}^2 N \gg 1$  and  $N \gg 1$ , or correspondingly,  $L \gg \ell_s$  and  $L \gg \ell_{\text{P}}$

In this case, on the CFT side, the system is described by the strongly coupled  $\mathcal{N} = 4$   $U(N)$  SYM with the  $N \rightarrow \infty$  limit (large  $N$  limit)<sup>\*3</sup>. On the AdS side, the system is described by the classical gravity, and we can neglect string excitation states whose mass is proportional to  $1/\ell_s$ . Namely, the system on the AdS side is well described by the type IIB supergravity. Thus, the AdS/CFT correspondence in this parameter region gives us a strong tool to investigate strongly coupled quantum field theories from the classical supergravity. This is one of the motivations for the investigation of the AdS/CFT correspondence.

- $g_{\text{YM}}^2 N \lesssim 1$  and  $N \sim 1$ , or correspondingly,  $L \lesssim \ell_s$  and  $L \sim \ell_{\text{P}}$

In this case, on the CFT side, the system is described by the weakly coupled  $\mathcal{N} = 4$   $U(N)$  SYM, where we can use the perturbation technique. On the AdS side, the system is described by the quantum gravity, and the string excitation states have to be taken into account. This situation might enable us to study the quantum gravity through AdS/CFT. This is another motivation for the investigation of the AdS/CFT correspondence.

<sup>\*3</sup> We often regard  $N \gg 1$  as the large  $N$  limit, namely  $N \rightarrow \infty$  limit.

CFT side		AdS side	
parameter region	description	parameter region	description
$g_{\text{YM}}^2 N \lesssim 1$	weak coupling	$L \lesssim \ell_s$	all states necessary
$g_{\text{YM}}^2 N \gg 1$	strong coupling	$L \gg \ell_s$	only massless states
$N \sim 1$	finite $N$	$L \sim \ell_{\text{P}}$	quantum gravity
$N \gg 1$	large $N$	$L \gg \ell_{\text{P}}$	classical gravity

Table 2.9 The possible situations depending on the parameter region in AdS/CFT. We might be able to make four situations combining the upper parameter relation (2.91a) and lower parameter relation (2.91b).

We summarize the possible situations depending on the parameters in Table 2.9.

The AdS/CFT correspondence arises from two faces of D3-branes in type IIB string theory: the open string perspective and closed string perspective. In what follows, we review how to obtain the correspondence from D3-branes.

### 2.3.1 D3-brane picture

In this subsection, we discuss the open string perspective and focus on fields on D3-branes. As a setup, we consider a stack of  $N$  coincident D3-branes in flat 10d Minkowski spacetime. These D3-branes are flat, and embedding of D3-branes into the 10d target space is given by

$$X^\mu = x^\mu \quad (\mu = 0, 1, 2, 3), \quad X^{i+3} = 0 \quad (i = 1, \dots, 6), \quad (2.92)$$

where  $x^\mu$  is the worldvolume coordinates on  $N$  D3-branes.

For a single D3-brane ( $N = 1$  in the above setup), we mentioned just above (2.79) that a 4d  $U(1)$  gauge theory arises on the D3-brane. Actually, in the low energy region  $E_{\text{ob}} \ll \ell_s^{-1}$  we can obtain the action of the 4d Maxwell theory by expanding the DBI action (2.79) with respect to  $\ell_s^2$ , where  $E_{\text{ob}}$  is the energy scale of the observation. This fact can be explicitly seen by expanding the DBI action (2.79) with respect to  $\ell_s^2$  under the background

$$e^{\langle\phi\rangle} = g_s, \quad B_{MN} = 0, \quad g_{MN} = \eta_{MN} = \text{diag}(-1, 1, \dots, 1). \quad (2.93)$$

In addition to this background of the NS-NS fields, we assume the following background for the R-R fields

$$C_k = 0 \quad \text{for } k \neq 4. \quad (2.94)$$

In this setup, coordinates  $X^{i+3}$  ( $i = 1, \dots, 6$ ) look like scalar fields living on the D3-brane from the viewpoint of the worldvolume theory. We define these scalar fields as

$\phi^i = X^{i+3}/2\pi\ell_s^2$ . Then, expanding the DBI action (2.79), we find the following action:

$$S_{\text{D3}}^{\text{DBI}} \simeq -\frac{1}{(2\pi)^3\ell_s^4 g_s} \int d^4x + \frac{1}{2\pi g_s} \int d^4x \left( -\frac{1}{4} F_{\mu\nu} F^{\mu\nu} - \frac{1}{2} \partial_\mu \phi^i \partial^\mu \phi^i \right) + \mathcal{O}(\ell_s^2), \quad (2.95)$$

The first term is merely a constant proportional to the worldvolume, and does not affect the physics, so we neglect it. Then, this is equivalent to the bosonic part of the  $\mathcal{N} = 4$   $U(1)$  Maxwell theory if we identify  $2\pi g_s = g_{\text{YM}}^2$ . More precisely, the axio-dilaton field  $\tau$  is identified as the complex coupling constant  $\tau$  define in (2.15).

As we mentioned in the first paragraph in Sec 2.2, the supersymmetry of type IIB theory is  $\mathcal{N} = (2, 0)$ . Now, half of the supersymmetry is broken due to the existence of the D3-brane. Namely, the D3-brane is a half BPS object, and we have the 4d  $\mathcal{N} = 4$  supersymmetry on this D3-brane. Since the DBI action (2.79) and its low energy expansion (2.95) include only the bosonic terms, we have to add the fermionic terms to (2.95) so that the action is invariant under  $\mathcal{N} = 4$ . Note that since we have eight degrees of freedom for bosons, the fermions also have the same degrees of freedom. Performing the supersymmetric completion for (2.95), we find the following action:

$$S = \frac{1}{g_{\text{YM}}^2} \int d^4x \left( -\frac{1}{4} F_{\mu\nu} F^{\mu\nu} + i\bar{\lambda}_I \bar{\sigma}^\mu \partial_\mu \lambda^I - \frac{1}{2} \partial_\mu \phi^i \partial^\mu \phi^i \right), \quad (2.96)$$

where  $\lambda_I$  ( $I = 1, 2, 3, 4$ ) is the Weyl spinor belonging to the spinor representation of  $SO(6)_R$  with the positive chirality. This is the complete action of  $\mathcal{N} = 4$   $U(1)$  Maxwell theory.

In the case of  $N$  coincident D3-branes, open strings have the Chan-Paton (CP) factors [32]. The CP factor runs from 1 to  $N$ , corresponding to the number of D3-branes, and is assigned to each endpoint of strings. We can regard the CP factor as the index of the gauge group  $U(N)$ , and an open string that ends on D3-branes is transformed as the adjoint representation of  $U(N)$ . Therefore, there is the  $U(N)$  gauge field on  $N$  coincident D3-branes, and the  $\mathcal{N} = 4$   $U(N)$  SYM is realized.

### 2.3.2 Black 3-brane solution

Here we discuss the closed string perspective. For simplicity, we do not take into account the string massive states. Besides this, we take the large  $N$  limit to avoid the difficulty of the quantum gravity. In this case,  $N$  D3-branes are viewed as a massive charged object under the R-R 4-form field  $C_4$ . Then the supergravity description is valid.

Now we are considering the type IIB supergravity. From the action (2.83), we obtain the 10d Einstein equation. Corresponding to (2.93) and (2.94), we assume the ansatz satisfying the following properties for the solution of the Einstein equation:

1. The solution is time independent.
2. R-R fields  $C_k = 0$  for  $k \neq 4$ .

3.  $B$ -field  $B_{MN} = 0$ .
4. The solution preserves the  $SO(1,3) \times SO(6)$  isometry as well as sixteen supercharges.
5. The metric  $g_{MN}$ , R-R 4-form field  $C_4$ , and the dilaton  $\phi$  has non-trivial solutions.
6. At infinity,  $g_{MN} = \eta_{MN}$  and  $e^\phi = g_s$ .

The solution is then given by

$$\begin{aligned} ds_{3\text{-brane}}^2 &= \frac{r^2}{L^2} \eta_{\mu\nu} dX^\mu dX^\nu + \frac{L^2}{r^2} \delta_{ij} dX^i dX^j \\ &= \frac{L^2}{z^2} (dz^2 + \eta_{\mu\nu} dX^\mu dX^\nu) + L^2 d\Omega_5^2, \end{aligned} \quad (2.97)$$

with the 5-form flux

$$F_5 = 16\pi \ell_s^4 N \epsilon_5, \quad (2.98)$$

where  $\mu, \nu = 0, \dots, 3$  and  $i, j = 4, \dots, 9$ . The radial coordinate  $r$  is defined by  $r^2 = \sum_i (X^i)^2$ .  $\epsilon_5$  is the volume form of  $S^5$  defined by  $r = L$ . In this solution we took the near horizon limit  $r \ll L$ . The metric (2.97) is nothing but the metric of  $AdS_5 \times S^5$ . Then this system describes closed strings propagating in  $AdS_5 \times S^5$  spacetime, namely, type IIB string theory on  $AdS_5 \times S^5$ .

So far, we have seen two perspectives in  $N$  coincident D3-branes, and we obtained the 4d  $\mathcal{N} = 4$   $U(N)$  SYM from the open string perspective and type IIB string theory on  $AdS_5 \times S^5$  from the closed string perspective. In this way, we can reach the idea of the AdS/CFT correspondence.

## 2.4 Agreement of the index in the large $N$ limit

We have seen the idea of the AdS/CFT correspondence in the last section. In this section, we confirm the agreement of the BPS partition function and the superconformal index on both sides in the large  $N$  limit. Although the BPS partition function depends on the coupling constant, this dependence is quite simple. It is known that the BPS partition function of the  $\mathcal{N} = 4$   $U(N)$  SYM in the weak coupling region is the same as that on the strong coupling region [16, 28]. Thus, this coupling dependence does not matter. On the contrary, the investigation of the BPS partition function gives us significant hints to study the superconformal index, so it is worthwhile to review the BPS partition function as well as the superconformal index.

### 2.4.1 BPS partition function

First we consider the  $\frac{1}{8}$ -BPS partition function defined in (2.28). Since this quantity is easier to calculate than the superconformal index, it is a good practice before calculating

the superconformal index. We calculate the BPS partition function on both sides.

### CFT side

Before calculating on the CFT side, we have to pay attention to the fact that the BPS partition function depends on the coupling constant. On the AdS side, it is difficult to consider the zero coupling limit because of the string massive states. Thus we only consider the non-zero coupling case. Then the BPS partition function on the CFT side is given by the series coefficients of the grand partition function (2.46).

Now it is easy to evaluate the BPS partition function in the large  $N$  limit from the grand partition function (2.46). It can be read off from the grand partition function by using a formula

$$a_\infty = \lim_{t \rightarrow 1} (1-t) f(t) \quad (2.99)$$

for a series expansion  $f(t) = \sum_{n=0}^{\infty} a_n t^n$  with  $|t| < 1$ . Then the BPS partition function of  $\mathcal{N} = 4$   $U(N)$  SYM in the large  $N$  limit is

$$Z_{U(\infty)}^{\frac{1}{8}\text{-BPS}} = \lim_{t \rightarrow 1} (1-t) \Xi_{U(*)}^{\frac{1}{8}\text{-BPS}}(x, y, z; t) = \text{Pexp} \left( \frac{1}{(1-x)(1-y)(1-z)} - 1 \right). \quad (2.100)$$

### AdS side

Let us consider the AdS side in which the system is described by type IIB supergravity. We want to know the corresponding object on the AdS side to the chiral primary operators, contributing to the BPS partition function. Actually, Witten noted that the corresponding objects are Kaluza-Klein modes on  $S^5$  [33], which are scalar particles with the angular momentum on  $S^5$ . Their spectrum has already been analyzed by [34]. Thus, we here confirm the agreement of the spectrum on both sides in terms of the BPS partition function.

There are the same global symmetry  $SO(2, 4) \times SO(6)$  on the AdS side as that on the CFT side. This symmetry is the isometry of  $AdS_5 \times S^5$  spacetime. On the CFT side,  $SO(2, 4)$  is the conformal symmetry, and  $SO(6)$  is the  $R$ -symmetry of  $\mathcal{N} = 4$  supersymmetry. Then the KK modes are also classified by this symmetry. Here we use the notation  $[j_L, j_R]_E^{(R_X, R_Y, R_Z)}$ , which we introduced below (2.55), to classify the KK modes under the global symmetry  $U(1)_H \times SU(2)_{j_L} \times SU(2)_{j_R} \times SO(6)_R \subset SO(2, 4) \times SO(6)$ . In terms of this notation, the KK modes belong to  $[0, 0]_n^{(n, 0, 0)}$  representation.

In the case of the superconformal index (2.52), we saw that the index respects the  $SU(3)_R \subset SO(6)_R$  symmetry because the particular choice of the supercharge breaks the symmetry as  $SO(6)_R \rightarrow SU(3)_R \times U(1)$ . This  $SU(3)_R$  is generated by  $R_X - R_Y$  and  $R_Y - R_Z$ . The index does not respect this  $U(1)$  symmetry because the supercharges are charged under this  $U(1)$ . However, in the case of the BPS partition function, since we do not consider the superpartner of the KK modes (or primary scalars on the CFT side),  $SU(3)_R \times U(1) = U(3)_R$  symmetry generated by  $R_X, R_Y$ , and  $R_Z$  is preserved. Namely,

the BPS partition function can be written in terms of the  $U(3)_R$  character. The  $U(3)$  character for the  $(m, n)$  representation is given by

$$\chi_{(m,n)}^{U(3)_R} = \bar{\chi}_{(m,n)}(x, y, z), \quad (2.101)$$

where  $\bar{\chi}_{(m,n)}(a, b, c)$  is defined in (A.32). Then the KK modes with  $E = n \geq 1$  belong to  $(n, 0)$  representation under  $U(3)_R$ , and the single-particle BPS partition function is just the summation of the character of the  $(n, 0)$  representation over  $n \geq 1$ :

$$i_{\text{BPS}}^{\text{KK}} = \sum_{n=1}^{\infty} \chi_{(n,0)}^{U(3)_R} = \frac{1}{(1-x)(1-y)(1-z)} - 1. \quad (2.102)$$

The BPS partition function is given by its plethystic exponential and therefore coincides with that on the CFT side, (2.100).

The next problem is how to include the finite  $N$  corrections into this expression. We will discuss the finite  $N$  corrections to the BPS partition function in the next chapter.

### 2.4.2 Superconformal index

Second, we consider the superconformal index in the large  $N$  limit. Unlike the BPS partition function, we do not care about the coupling constant because the index does not depend on the coupling constant.

#### CFT side

Now we consider the large  $N$  limit of the localization formula (2.58). This can be obtained by the saddle point method. In order to use it, we need to perform the variable change  $z_i \rightarrow e^{i\theta_i}$  and pick up the leading term in the large  $N$  limit from the expression. The expression of the index after the variable change becomes

$$\mathcal{I}_{U(N)} = \frac{1}{N!} \int_{-\pi}^{\pi} \prod_{i=1}^N \frac{d\theta_i}{2\pi} \exp \left[ - \sum_{n=1}^{\infty} \frac{1}{n} \left\{ \sum_{i \neq j} (1 - i_{\text{sp}}(x^n)) \cos[n(\theta_i - \theta_j)] - N i_{\text{sp}}(x^n) \right\} \right], \quad (2.103)$$

where an argument  $x$  in  $i_{\text{sp}}(x)$  stands for  $(q, y, u, v)$ . If we take the large  $N$  limit, terms with  $\sum_{i,j}$  is of order  $N^2$ , and it is a leading order contribution to the index. On the other hand, the term  $N i_{\text{sp}}$  is of order  $N$  and can be neglected. Likewise, since the Weyl factor  $1/N!$  is about  $\exp(-N \log N + N)$  in the large  $N$  limit, we also neglect it. After the computation, we have to normalize the index so that  $\mathcal{I}(x=0) = 1$ .

Then the index in the large  $N$  limit is given by

$$\mathcal{I}_{U(N)} \stackrel{N \gg 1}{\approx} \int_{-\pi}^{\pi} \prod_{i=1}^N \frac{d\theta_i}{2\pi} \exp \left( - \sum_{n=1}^{\infty} \frac{1}{n} \sum_{i \neq j} (1 - i_{\text{sp}}(x^n)) \cos[n(\theta_i - \theta_j)] \right). \quad (2.104)$$

Now, we introduce the eigenvalue density  $\rho(\theta)$  given by

$$\rho(\theta) = \frac{1}{N} \sum_{i=1}^N \delta(\theta - \theta_i). \quad (2.105)$$

Then, the summation  $\sum_i$  is replaced by the integration with the eigenvalue density:

$$\sum_i \rightarrow N \int d\theta \rho(\theta). \quad (2.106)$$

Under this manipulation, the integration over  $\theta_i$  is interpreted as a summation over a configuration of the eigenvalue density  $\rho(\theta)$ . Therefore

$$\prod_i d\theta_i \rightarrow \prod_x d\rho(x) d\rho^*(x) \equiv \mathcal{D}\rho \mathcal{D}\rho^*. \quad (2.107)$$

More precisely, we should take into account the Jacobian related with  $\theta_i \rightarrow \rho(\theta)$ . However, the Jacobian is irrelevant in the large  $N$  limit [35], and we neglect it.

We now have the following integral:

$$\mathcal{I}_{U(N)} \stackrel{N \gg 1}{\approx} \int \mathcal{D}\rho \mathcal{D}\rho^* e^{-S_{\text{eff}}}, \quad (2.108a)$$

$$S_{\text{eff}} = \frac{N^2}{2\pi} \int d\theta d\theta' \rho(\theta) \rho^*(\theta') V(\theta - \theta'), \quad (2.108b)$$

$$V(\theta) = 2\pi \sum_{n=1}^{\infty} \frac{1}{n} (1 - i_{\text{sp}}(x^n)) \cos(n\theta). \quad (2.108c)$$

If we carry out the Fourier expansion for  $\rho(\theta)$  as

$$\rho(\theta) = \sum_{n=0}^{\infty} \rho_n e^{-in\theta}, \quad (2.109)$$

the effective action becomes

$$S_{\text{eff}} = N^2 \sum_{n=1}^{\infty} \frac{|\rho_n|^2}{n} (1 - i_{\text{sp}}(x^n)). \quad (2.110)$$

This effective action  $S_{\text{eff}}$  has a critical point at  $\rho_{n \geq 1} = 0, \rho_0 = 1$ . Thus we can evaluate

$[j_L, j_R]_E^{(R_X, R_Y, R_Z)}$	Condition	Contribution
$[0, 0]_n^{(n, 0, 0)}$	$n \geq 1$	$q^n \chi_{(n, 0)}$
$[\frac{1}{2}, 0]_{n+\frac{1}{2}}^{(n-\frac{1}{2}, \frac{1}{2}, \frac{1}{2})}$	$n \geq 1$	$-q^{n+\frac{1}{2}} \chi_1^J \chi_{(n-1, 0)}$
$[0, \frac{1}{2}]_{n+\frac{1}{2}}^{(n-\frac{1}{2}, \frac{1}{2}, -\frac{1}{2})}$	$n \geq 1$	$-q^{n+1} \chi_{(n-1, 1)}$
$[0, 1]_{n+1}^{(n-1, 0, 0)}$	$n \geq 1$	$q^{n+2} \chi_{(n-1, 0)}$
$[0, 0]_{n+1}^{(n-1, 1, 1)}$	$n \geq 2$	$q^{n+1} \chi_{(n-2, 0)}$
$[\frac{1}{2}, \frac{1}{2}]_{n+1}^{(n-1, 1, 0)}$	$n \geq 2$	$q^{n+\frac{3}{2}} \chi_1^J \chi_{(n-2, 1)}$
$[\frac{1}{2}, 1]_{n+\frac{3}{2}}^{(n-\frac{3}{2}, \frac{1}{2}, \frac{1}{2})}$	$n \geq 2$	$-q^{n+\frac{5}{2}} \chi_1^J \chi_{(n-2, 0)}$
$[0, \frac{1}{2}]_{n+\frac{3}{2}}^{(n-\frac{3}{2}, \frac{3}{2}, \frac{1}{2})}$	$n \geq 3$	$-q^{n+2} \chi_{(n-3, 1)}$
$[0, 1]_{n+2}^{(n-2, 1, 1)}$	$n \geq 3$	$q^{n+3} \chi_{(n-3, 0)}$

Table 2.10 The KK modes on  $S^5$  with  $\bar{\Delta} = 0$ . This list contains only the highest weight Cartan charges. Note that we have to sum over the full representations as the character for  $SU(3)_R$  and  $SU(2)_{j_L}$  since the index respects these symmetries. The  $SU(3)_R$  symmetry is generated by  $R_X - R_Y$  and  $R_Y - R_Z$ . The characters for these symmetries are defined in (A.34) and (2.55).

the large  $N$  index by the Gaussian integral around this critical point. Note that the classical contribution vanishes. After the Gaussian integral and normalizing the index so that  $\mathcal{I}(x=0) = 1$ , we finally have

$$\mathcal{I}_{U(\infty)} = \prod_{n=1}^{\infty} \frac{1}{1 - i_{\text{sp}}(x^n)}. \quad (2.111)$$

Next, we will see this expression exactly coincides with the index calculated from the Kaluza-Klein modes on  $S^5$  on the AdS side.

### AdS side

The large  $N$  limit of the BPS partition function on the AdS side was obtained by the summation of the KK modes on  $S^5$ . The superconformal index is a generalization of the BPS partition function by including fermionic fields, gauge fields, and their descendants. This generalization is a superconformal completion in the context of the algebra. Thus we can find the superconformal index for the KK modes by considering the superconformal completion of  $[0, 0]_n^{(n, 0, 0)}$ . After the superconformal completion of  $[0, 0]_n^{(n, 0, 0)}$  we have representations listed in Table 2.10 with its contribution to the superconformal index. These representations are also found by the  $S^5$  compactification of type IIB string theory. See the reference [34].

Let us denote all contributions listed in Table 2.10 by  $s_n$ :

$$\begin{aligned}
s_n &= \chi_{(n,0)} q^n - \chi_1^J \chi_{(n-1,0)} q^{n+\frac{1}{2}} - (\chi_{(n-1,0)} - \chi_{(n-2,0)}) q^{n+1} \\
&\quad + \chi_1^J \chi_{(n-2,1)} q^{n+\frac{3}{2}} + (\chi_{(n-1,0)} - \chi_{(n-3,1)}) q^{n+2} - \chi_1^J \chi_{(n-2,0)} q^{n+\frac{5}{2}} + \chi_{(n-3,0)} q^{n+3}
\end{aligned} \tag{2.112}$$

with  $n \geq 1$ . Although we cannot take a negative value for  $(m, n)$  in  $\chi_{(m,n)}$  essentially, we can do it formally by using the Weyl character formula, and this generates the correct spectrum for the KK modes. Physically, terms including  $\chi_{(m,n)}$  with negative  $m$  or  $n$  correspond to the equations of motions of the KK particles. Then the single-particle index is given by

$$\begin{aligned}
i_{\text{sp}}^{\text{KK}} &= \frac{1}{(1 - q^{\frac{3}{2}} y)(1 - q^{\frac{3}{2}} y^{-1})} \sum_{n=1}^{\infty} s_n \\
&= \frac{1}{1 - uq} + \frac{1}{1 - \frac{v}{u}q} + \frac{1}{1 - \frac{1}{v}q} - \frac{1}{1 - q^{\frac{3}{2}}y} - \frac{1}{1 - q^{\frac{3}{2}}y^{-1}} - 1,
\end{aligned} \tag{2.113}$$

The multi-particle index is just the plethystic exponential of the single-particle index (2.113):

$$\mathcal{I}_{\text{AdS}}^{\text{KK}} = \text{Pexp}(i_{\text{sp}}^{\text{KK}}) = \prod_{n=1}^{\infty} \frac{(1 - q^{\frac{3}{2}n} y^n)(1 - q^{\frac{3}{2}n} y^{-n})}{(1 - u^n q^n)(1 - \frac{v^n}{u^n} q^n)(1 - v^{-n} q^n)}, \tag{2.114}$$

which exactly coincides with the large  $N$  index (2.111) on the CFT side.



## Chapter 3

# Finite $N$ Corrections to the Superconformal Index

In this chapter, we discuss the finite  $N$  corrections to the BPS partition function and the superconformal index following the author's and his collaborators' paper [22]. At the beginning, let us review the fact that the KK index (2.114) partially reproduces the finite  $N$  index on the CFT side as well. To see this, we expand (2.114) with respect to  $q$  as

$$\begin{aligned} \mathcal{I}_{\text{AdS}}^{\text{KK}} = & 1 + \chi_{(1,0)} q - \chi_1^J q^{\frac{3}{2}} + (-\chi_{(0,1)} + 2\chi_{(2,0)}) q^2 - \chi_1^J \chi_{(1,0)} q^{\frac{5}{2}} \\ & + (2 - \chi_2^J - \chi_{(1,1)} + 3\chi_{(3,0)}) q^3 + (\chi_1^J \chi_{(0,1)} - 2\chi_1^J \chi_{(2,0)}) q^{\frac{7}{2}} \\ & + (\chi_{(0,2)} + 2\chi_{(1,0)} - \chi_2^J \chi_{(1,0)} - 2\chi_{(2,1)} + 5\chi_{(4,0)}) q^4 + \mathcal{O}(q^{\frac{9}{2}}). \end{aligned} \quad (3.1)$$

Comparing it with the finite  $N$  index on the CFT side (2.59), (2.60) and (2.61), we find the following fact:

$$\mathcal{I}_{U(N)}^{\text{CFT}} = \mathcal{I}_{\text{AdS}}^{\text{KK}} - \chi_{(N+1,0)} q^{N+1} + \mathcal{O}(q^{N+\frac{3}{2}}). \quad (3.2)$$

Our question is what is the corresponding object of this extra term  $-\chi_{(N+1,0)} q^{N+1} + \dots$  on the AdS side.

On the CFT side, the meaning of this extra term is clear. Since we proved  $\mathcal{I}_{U(\infty)}^{\text{CFT}} = \mathcal{I}_{\text{AdS}}^{\text{KK}}$ , above relation is written into

$$\mathcal{I}_{U(N)}^{\text{CFT}} = \mathcal{I}_{U(\infty)}^{\text{CFT}} - \chi_{(N+1,0)} q^{N+1} + \mathcal{O}(q^{N+\frac{3}{2}}). \quad (3.3)$$

Then, the extra term means that there are additional constraints for BPS operators. For simplicity, let us consider the  $N = 2$  case. We have following BPS trace operators

$$\text{Tr}\Phi, \quad \text{Tr}(\Phi^2), \quad \text{Tr}(\Phi^3), \quad \dots, \quad (3.4)$$

where  $\Phi$  is one of the adjoint scalar fields  $X, Y, Z$ . In the large  $N$  limit, all these operators are independent. However, in the  $N = 2$  case, some operators in (3.4) are not independent

operators. Since the gauge group is  $U(2)$ ,  $T_a = (1, \sigma_i)$  and hence we have a following relation<sup>\*1</sup>:

$$\mathrm{Tr}(\Phi^3) = \frac{3}{2}\mathrm{Tr}(\Phi^2)\mathrm{Tr}\Phi - \frac{1}{2}(\mathrm{Tr}\Phi)^3. \quad (3.5)$$

Thus, the operator  $\mathrm{Tr}(\Phi^3)$  is not the independent operator, and we must not count this contribution in the calculation of the index. This indicates that  $\mathrm{Tr}(\Phi^n)$  with  $n > N$  are not independent operators, namely

$$E_{\mathrm{op}} \leq N, \quad (3.6)$$

where  $E_{\mathrm{op}}$  is the conformal dimension of the independent trace operators. Then we have to subtract the contributions of operators, which can be written by other independent operators, from the large  $N$  index to obtain the finite  $N$  index. More precisely, if we consider all the combinations of the scalar fields  $X, Y, Z$  to construct  $E_{\mathrm{op}} = 3$  operators, we find the following ten scalar operators of the form  $\mathrm{Tr}(\Phi^3)$ :

$$\begin{aligned} &\mathrm{Tr}(X^3), & \mathrm{Tr}(X^2Y), & \mathrm{Tr}(XY^2), & \mathrm{Tr}(Y^3), & \mathrm{Tr}(X^2Z), \\ &\mathrm{Tr}(XZ^2), & \mathrm{Tr}(Y^2Z), & \mathrm{Tr}(YZ^2), & \mathrm{Tr}(XYZ), & \mathrm{Tr}(Z^3), \end{aligned} \quad (3.7)$$

where we ignored the order of the operators. These operators form the  $(3, 0)$  representation of  $SU(3)_R \subset SO(6)_R$ . Summing the contributions of these operators, we obtain  $\chi_{(3,0)} q^3$ . Hence, the extra term in (3.5) can be understood as the subtraction of the not-independent operators from the large  $N$  limit.

Again, what is the corresponding object of the extra terms on the AdS side? To solve this problem is the main theme of this thesis. Let us recall the parameter relation (2.91b). Since the D3-brane tension  $T_3$  defined in (2.80) is proportional to  $\ell_{\mathrm{P}}^{-4}$ , the relation (2.91b) can be rewritten as

$$N = 2\pi^2 T_3 L^4. \quad (3.8)$$

If  $N \gg 1$ ,  $T_{\mathrm{D}3} \gg L^{-4}$ , that means a D3-brane on the AdS side is too heavy to participate in the physics. On the other hand, if  $N$  is of order unity (finite  $N$ ),  $T_{\mathrm{D}3} \sim L^{-4}$  and we may need to include the effect of D3-branes on the AdS side.

Even if D3-branes appear on the AdS side in the finite  $N$  region, how do we realize the condition (3.6)? The answer is to wrap D3-brane on a three-cycle in  $S^5$  [17]. Such a D3-brane is called a giant graviton or simply a wrapped D3-brane. In this thesis, we adopt the name ‘‘wrapped D3-brane.’’ Because the worldvolume of a wrapped D3-brane is bounded by the maximal circle of  $S^5$ , namely  $S^3$ , we can reproduce the condition (3.6) on the AdS side. Note that the energy of a wrapped D3-brane is proportional to its volume.

---

<sup>\*1</sup> This relation is the simple version of (2.41).

Now the condition is regarded as

$$\text{volume of a wrapped D3-brane} \leq \text{Vol}(S_{\text{Max}}^3) = 2\pi^2 L^3. \quad (3.9)$$

On the AdS side, the conformal dimension is translated as the energy of the corresponding object times the AdS radius  $L$ . Therefore, we obtain the condition

$$\frac{E_{\text{D3}}}{T_3 L} \leq 2\pi^2 L^3 \quad \iff \quad E_{\text{D3}} \leq N, \quad (3.10)$$

where  $E_{\text{D3}}$  is the energy of a wrapped D3-brane scaled by the AdS radius  $L$ . Therefore we expect that the wrapped D3-branes may give the finite  $N$  corrections to the index. The preliminary investigation is given by [19]. In what follows, we compute the finite  $N$  BPS partition function and superconformal index on the AdS side by using wrapped D3-brane as well as KK modes following [22]. After the calculation, we compare our results with those on the CFT side.

### 3.1 BPS partition function

In this section, we reproduce the BPS partition function for the interacting  $\mathcal{N} = 4$   $U(N)$  SYM on the AdS side, because the calculation of the BPS partition function gives us many instructive experiences for the index in spite of their ease. The reproduction of the BPS partition function shows non-trivial evidence for the AdS/CFT correspondence. Our strategy in the finite  $N$  region is to consider the wrapped D3-branes discussed above. This section is also meant to be a preparation for the analysis of the superconformal index on the AdS side that will be discussed in the next section.

The first problem is what shape of wrapped D3-branes contribute to the BPS partition function. This problem is elegantly solved by Mikhailov in his beautiful paper [36]. He showed that the any  $\frac{1}{8}$ -BPS wrapped D3-branes are given by an intersection between a holomorphic surface in  $\mathbb{C}^3$  and  $S^5 \subset \mathbb{C}^3$ . Let be  $X$ ,  $Y$  and  $Z$  be complex coordinates on  $\mathbb{C}^3$ . Then  $S^5$  is expressed by

$$|X|^2 + |Y|^2 + |Z|^2 = L^2 = 1, \quad (3.11)$$

where  $L$  is the radius equal to the AdS radius<sup>\*2</sup>. Any holomorphic surfaces are given by a holomorphic function  $f(X, Y, Z)$  on  $\mathbb{C}^3$ . Mikhailov claims that the worldvolume of any wrapped D3-branes is given by a holomorphic surface

$$f(X, Y, Z) = 0 \quad (3.12)$$

---

<sup>\*2</sup> We take the  $L = 1$  unit here.

imposed by (3.11). The Taylor expansion of the holomorphic function is

$$f(X, Y, Z) = \sum_{p, q, r=0}^{\infty} c_{pqr} X^p Y^q Z^r = \sum_{n=0}^{\infty} \sum_{p+q+r=n} c_{pqr} X^p Y^q Z^r. \quad (3.13)$$

The value of coefficients  $c_{pqr}$  determines the configuration of wrapped D3-branes. Then we treat the coefficients  $c_{pqr}$  as dynamical variables. To obtain the BPS partition function of wrapped D3-branes, we need the quantization of wrapped D3-branes. This can be carried out by the geometric quantization [29, 37].

Since the overall factor is irrelevant for  $f$  and the configuration, we can regard coefficients as projective coordinates of  $\mathbb{C}P^\infty$ . There are two complicated issues. One is that there may be different holomorphic functions that give the same D3-brane configurations. The other is that there may be holomorphic surfaces that do not intersect with  $S^5$ . Even if we take into account the issues, the result is the same as what we obtained by neglecting the issues [29]. As a result, we can treat the coefficients as independent variables.

Thanks to the result of the geometric quantization, we can treat each term for fixed  $n$  in (3.13) independently. Let us focus on the degree  $n$  holomorphic surface given by

$$\sum_{p+q+r=n} c_{pqr} X^p Y^q Z^r = 0. \quad (3.14)$$

We define  $n$ -ple wrapped D3-branes as D3-branes represented by (3.14). Let  $Z_n^{\text{D3}}$  be contributions to the BPS partition function from  $n$ -ple wrapped D3-branes. Then the BPS partition function on the AdS side can be written in the form of

$$Z_N^{\text{AdS}} = Z_{\text{BPS}}^{\text{KK}} \left( 1 + \sum_{n=1}^{\infty} Z_n^{\text{D3}} \right). \quad (3.15)$$

$Z_{\text{BPS}}^{\text{KK}}$  is the BPS partition function in the large  $N$  limit on the AdS side

$$Z_{\text{BPS}}^{\text{KK}} = \text{Pexp}(i_{\text{BPS}}^{\text{KK}}), \quad (3.16)$$

where  $i_{\text{BPS}}^{\text{KK}}$  is given by (2.102).

In our CFT analysis, we have calculated the BPS partition function in the exact form like (2.48) and (2.49). However, here we would like to calculate the finite  $N$  corrections to the index in each power of  $n$ . Then it is convenient to define the  $q$  fugacity associated with the energy  $E$  of wrapped D3-branes in the unit of AdS radius  $L$ . ( $E$  is the conformal dimension of the corresponding operators on the CFT side.) Then the definition of the BPS partition function (2.28) is modified as

$$Z(x, y, z; q) = \text{tr}(q^H x^{R_X} y^{R_Y} z^{R_Z}), \quad (3.17)$$

Note that the fugacity  $q$  is redundant because of the BPS condition

$$E - (R_X + R_Y + R_Z) = 0. \quad (3.18)$$

Although It is then not inherently necessary to define the BPS partition function, we can see the finite  $N$  corrections due to the wrapped D3-branes by expanding the BPS partition function with respect to  $q$ .

Let us consider the  $n = 1$  case as a first non-trivial finite  $N$  correction to the BPS partition function. In this case, the most general holomorphic surface is

$$aX + bY + cZ = 0. \quad (3.19)$$

The phase space is thus  $\mathbb{C}P^2$  whose homogeneous coordinates are  $(a, b, c)$ . Our strategy that we take here is to treat  $Z = 0$  as a ground state and others as its excitations. In order to do it, we consider the D3-brane action (2.82) for the wrapped D3-brane located  $Z = 0$ . The DBI action describes a 4d field theory on the worldvolume, and the CS action comes from the coupling to the background R-R 4-form field  $C_4$ .

First, let us consider the DBI action. It is easier to work in the polar coordinates than the Cartesian coordinates in  $\mathbb{C}^3$ . The metric of  $AdS_5 \times S^5$  with the polar coordinates is

$$ds_{10d}^2 = -\cosh^2 r dt^2 + dr^2 + \sinh^2 r d\Omega_3^2 + d\theta^2 + \sin^2 \theta d\phi^2 + \cos^2 \theta [d\psi_1^2 + \sin^2 \psi_1 (d\psi_2^2 + \sin^2 \psi_2 d\psi_3^2)], \quad (3.20)$$

where  $(t, r, \Omega_3)$  forms  $AdS_5$  while  $(\theta, \phi, \psi_1, \psi_2, \psi_3)$  forms  $S^5$ .  $Z = 0$  means  $\theta = 0$  and  $r = 0$  in the polar coordinates. Because our purpose is to consider the fluctuations on the wrapped D3-brane, we calculate the induced metric of the D3-brane and expand  $r$  and  $\theta$  around  $r = 0, \theta = 0$ . The DBI action with the induced metric up to quadratic terms of  $r$  and  $\theta$  is then

$$S_{\text{DBI}}^{\text{D3}} = -T_3 \int_{\mathbb{R} \times S^3} d^4x \sqrt{-g_0} \times \left[ 1 - \frac{1}{2} \left( \sum_{W=X,Y,Z} (|\dot{\Phi}_W|^2 - |\nabla \Phi_W|^2) + 3|\Phi_Z|^2 - |\Phi_X|^2 - |\Phi_Y|^2 \right) \right], \quad (3.21)$$

where  $x^a = (t, \psi_1, \psi_2, \psi_3)$  is the worldvolume coordinates of the wrapped D3-brane and  $\sqrt{-g_0} = \sin^2 \psi_1 \sin \psi_2$  is its volume element. The D3-brane tension  $T_3$  is given by

$$T_3 = \frac{1}{(2\pi)^3 \ell_P^4} = \frac{N}{2\pi^2 L^4}. \quad (3.22)$$

We introduced three complex scalar fields as

$$\Phi_Z = \theta e^{i\phi}, \quad |\Phi_X|^2 + |\Phi_Y|^2 = r^2. \quad (3.23)$$

These fluctuation modes must carry the non-trivial spin charges  $j_L$  and  $j_R$  because scalar fields  $\Phi_X$  and  $\Phi_Y$  represent fluctuations of  $AdS_5$  directions. The BPS partition function does not have contributions with the non-trivial spin charge, so we neglect them in the calculation of the BPS partition function.

Next, we consider the CS action. Because the CS action describes the coupling to the R-R 4-form field, the action is given by<sup>\*3</sup>

$$S_{\text{CS}}^{\text{D3}} = \int_{\mathbb{R} \times S^3} C_4 \quad (3.24)$$

To find the explicit form of the R-R 4-form field  $C_4$ , we can use the flux quantization condition

$$\int_{S^5} dC_4 = 2\pi N \quad (3.25)$$

followed by (2.75). Using the polar coordinates, we find

$$C_4 = \frac{N}{2\pi^2} \dot{\phi} \cos^4 \theta \sqrt{-g_0} dt \wedge d\psi_1 \wedge d\psi_2 \wedge d\psi_3. \quad (3.26)$$

Expanding  $\cos^4 \theta$  up to quadratic terms, the CS action becomes

$$\begin{aligned} S_{\text{CS}}^{\text{D3}} &= \frac{N}{2\pi^2} \int d^4x \sqrt{-g_0} \dot{\phi} (1 - 2\theta^2) \\ &= \frac{N}{2\pi^2} \int d^4x \sqrt{-g_0} \dot{\phi} + \frac{iN}{2\pi^2} \int d^4x \sqrt{-g_0} (\Phi_Z^* \dot{\Phi}_Z - \Phi_Z \dot{\Phi}_Z^*) \end{aligned} \quad (3.27)$$

In summary, the D3-brane action is given by the classical action and fluctuations:

$$S^{\text{D3}} = S_{\text{cl}}^{\text{D3}} + S_{\text{fluc}}^{\text{D3}}, \quad (3.28a)$$

$$S_{\text{cl}}^{\text{D3}} = \frac{N}{2\pi^2} \int d^4x \sqrt{-g_0} (\dot{\phi} - 1), \quad (3.28b)$$

$$\begin{aligned} S_{\text{fluc}}^{\text{D3}} &= \frac{N}{2\pi^2} \int d^4x \sqrt{-g_0} \left[ \frac{1}{2} (|\dot{\Phi}_X|^2 - |\nabla \Phi_X|^2 + |\dot{\Phi}_Y|^2 - |\nabla \Phi_Y|^2 + |\dot{\Phi}_Z|^2 - |\nabla \Phi_Z|^2) \right. \\ &\quad \left. + \frac{3}{2} |\Phi_Z|^2 - \frac{1}{2} (|\Phi_X|^2 + |\Phi_Y|^2) + i(\Phi_Z^* \dot{\Phi}_Z - \Phi_Z \dot{\Phi}_Z^*) \right]. \end{aligned} \quad (3.28c)$$

Let us consider the classical contribution. The energy of the D3-brane corresponds to

---

<sup>\*3</sup> Other R-R fields are set to be zero.

the potential term in the classical Lagrangian. Namely,

$$E = \frac{N}{2\pi^2} \int_{S^3} d^3x \sqrt{-g_0} = N, \quad (3.29)$$

in the unit of the AdS radius. The wrapped D3-brane feels the R-R flux, so that the wrapped D3-brane has a non-trivial angular momentum. In this configuration, this is just  $R_Z$  corresponding to the  $R$ -charge on the CFT side. This is calculated as

$$R_Z = \frac{\partial L_{\text{cl}}}{\partial \dot{\phi}} = \frac{N}{2\pi^2} \int_{S^3} d^3x \sqrt{-g_0} = N. \quad (3.30)$$

Therefore, the  $Z = 0$  configuration satisfies the BPS condition  $E = R_Z$ . This result is consistent with Mikhailov's claim. This information tells us that the classical contribution to the BPS partition function is  $(qz)^N$ .

Let us move on to the calculation of the fluctuation modes on the wrapped D3-branes. As we mentioned below (3.23), the fluctuation modes related with  $\Phi_X$  and  $\Phi_Y$  is irrelevant for the BPS partition function, so we only take into account terms including  $\Phi_Z$ . The equation of motion for  $\Phi_Z$  is

$$-\ddot{\Phi}_Z + \nabla^2 \Phi_Z + 3\Phi_Z + 4i\dot{\Phi}_Z = 0, \quad (3.31)$$

where  $\nabla^2$  is the Laplacian on  $S^3$ . If we assume the solution takes the form  $e^{-iEt}Y_l$  using the spherical harmonics  $Y_l$  on  $S^3$  we have the following second-order equations for  $E$ :

$$(E - l + 1)(E + l + 3) = 0, \quad (3.32)$$

where we used the eigenvalue of the Laplacian given by  $-l(l + 2)$ . The solution corresponding to the BPS fluctuation modes is

$$E = l - 1, \quad (3.33)$$

because  $(l - 1) - (-l - 3) = 2l + 2 > 0$ . From the BPS condition (3.18) we find  $R_X + R_Y + R_Z = l - 1$ . The fluctuation modes around  $Z = 0$  must also be given by the holomorphic function, and this holomorphic function has the form

$$Z \propto \sum_{p,q=0}^{\infty} X^p Y^q. \quad (3.34)$$

According to [36], the time dependence of a holomorphic surface is

$$(X(t), Y(t), Z(t)) = (e^{it}X(0), e^{it}Y(0), e^{it}Z(0)). \quad (3.35)$$

If we assume that the initial configuration for each mode is given by  $Z(0) = X(0)^p Y(0)^q$ ,

the  $Z(t)$  at time  $t$  becomes

$$Z(t) = e^{-i(p+q-1)t} X(t)^p Y(t)^q. \quad (3.36)$$

Now we recognize that the  $E = -1$  at  $l = 0$  comes from  $Z$  itself while  $l = p + q$  modes come from  $X^p Y^q$ \*4. We denote this scalar mode as  $\bar{\phi}^{(l)} : [0, 0]_{l-1}^{(p,q,0)}$ . The single-particle BPS partition function coming from these scalar modes on the wrapped D3-brane located  $Z = 0$  is then

$$i_{\text{sp}}^{\text{BPS}} = \sum_{p,q=0}^{\infty} q^{p+q-1} z^{-1} x^p y^q = \frac{(qz)^{-1}}{(1-qx)(1-qy)}. \quad (3.37)$$

Hence, the single-particle BPS partition function on the wrapped D3-brane is obtained as

$$Z_{Z=0}^{\text{D3}} = (qz)^N \text{Pexp} \left( \frac{(qz)^{-1}}{(1-qx)(1-qy)} \right). \quad (3.38)$$

The Taylor expansion with respect to  $q$  is

$$i_{\text{sp}}^{\text{BPS}} = \frac{1}{qz} + \left( \frac{x}{z} + \frac{y}{z} \right) + \mathcal{O}(q). \quad (3.39)$$

Thus we have a negative energy mode and two zero energy modes. We call a negative energy mode a tachyonic mode and call a zero energy mode a zero mode simply. The existence of a tachyonic mode implies that there are lower energy modes than the  $Z = 0$  configuration. Actually, there are smaller worldvolume configurations than  $Z = 0$  since it is a great circle of  $S^5$ . Mathematically, the plethystic exponential of a tachyonic term does not work as far as  $z < 1, q < 1$ . So we temporarily impose  $z > 1, q > 1$  and treat the plethystic exponential of a tachyonic term as follows:

$$\text{Pexp} \left( \frac{1}{qz} \right) = \frac{1}{1 - (qz)^{-1}} = -\frac{qz}{1 - qz} = -qz \text{Pexp}(qz). \quad (3.40)$$

In this treatment, the tachyonic term hence serves to raise the overall power of  $q$  by one. Now that the first term of the finite  $N$  corrections is not  $(qz)^N$  but  $-(qz)^{N+1}$ . This can be understood as follows. On the CFT side, there exist finite number independent chiral primary operators in the finite  $N$  region, while there exist infinite number operators in the large  $N$  limit. For  $U(2)$  theory as an example, we have only two independent operators  $\text{Tr}Z$  and  $\text{Tr}Z^2$  for the  $\frac{1}{2}$ -BPS sectors. Then the difference between the BPS partition function for the  $U(2)$  theory and the  $U(\infty)$  theory starts from  $(qz)^{2+1}$  and the minus sign can be interpreted as a subtraction of extra operators from the large  $N$  theory to become the  $U(2)$  theory. On the other hand, we have no physical interpretation on the AdS side.

---

\*4 Note that the scalar fields  $\Phi_{W=X,Y,Z}$  are proportional to the coordinates  $X, Y, Z$ .

Up to now, we are only able to handle it mathematically.

The zero modes are also important. They never describe higher energy configurations because of no  $q$ -dependence. Instead of this, they correspond to the degenerating ground states other than  $Z = 0$ . Actually, the plethystic exponential of the zero modes contains all degenerating states:

$$\begin{aligned} -(qz)^{N+1} \text{Pexp} \left( \frac{x}{z} + \frac{y}{z} \right) &= -\frac{(qz)^{N+1}}{\left(1 - \frac{x}{z}\right)\left(1 - \frac{y}{z}\right)} \\ &= -q^{N+1} z^{N+1} \left( 1 + \frac{x}{z} + \frac{x^2}{z^2} + \dots \right) \left( 1 + \frac{y}{z} + \frac{y^2}{z^2} + \dots \right). \end{aligned} \quad (3.41)$$

Indeed, this formula includes not only all degenerating ground states but also extra states as an infinite series. This fact reflects that the configuration space is  $\mathbb{C}P^2$ . We have to consider other patches of  $\mathbb{C}P^2$  in addition to  $Z = 0$ . Actually, the patches including  $Z = 0$  is spanned by coordinates  $(a/c, b/c)$  but never includes  $X = 0$  and  $Y = 0$  since we have to set to be  $c = 0$  to realize  $X = 0$  and  $Y = 0$ .

The discussion for other patches is essentially the same as that of  $Z = 0$ . To obtain the fluctuation modes coming from  $X = 0$  and  $Y = 0$ , only we have to do is to exchange the fugacities  $(x, y, z)$  symmetrically. Actually, this manipulation corresponds to the Weyl reflection of the  $U(3)_R$  symmetry. We call this manipulation the Weyl completion.

After the Weyl completion, the BPS partition functions corresponding to  $Y = 0$  and  $Z = 0$  are given by

$$Z_{X=0}^{\text{D}3} = (qx)^N \text{Pexp} \left( \frac{(qx)^{-1}}{(1 - qy)(1 - qz)} \right), \quad (3.42)$$

$$Z_{Y=0}^{\text{D}3} = (qy)^N \text{Pexp} \left( \frac{(qy)^{-1}}{(1 - qz)(1 - qx)} \right) \quad (3.43)$$

To cancel the extra terms in (3.41) using the zero modes in the single-particle partition function for  $X = 0$  and  $Y = 0$ , all we have to do is to sum up three patches. To see this procedure does work, let us focus on the term  $-(qz)^{N+1} \left( 1 + \frac{x}{z} + \frac{x^2}{z^2} + \dots \right)$  in (3.41).

The extra terms in this expression are actually canceled by the term  $-\frac{(qx)^{N+1}}{1 - \frac{z}{x}}$  in  $X = 0$ :

$$-\frac{(qz)^{N+1}}{1 - \frac{x}{z}} = -q^{N+1} (z^{N+1} + z^N x + \dots + zx^N + x^{N+1} + x^{N+2} z^{-1} + \dots), \quad (3.44)$$

$$-\frac{(qx)^{N+1}}{1 - \frac{z}{x}} = \frac{q^{N+1} x^{N+1} \frac{x}{z}}{1 - \frac{x}{z}} = q^{N+1} (x^{N+2} z^{-1} + \dots), \quad (3.45)$$

where we performed the Taylor expansion of the denominator in a region  $\left| \frac{x}{z} \right| < 1$ . Note that this cancellation can always occur since the summation of two expressions is the Weyl

character formula of  $U(2) \subset U(3)_R$ :

$$-\frac{(qz)^{N+1}}{1-\frac{x}{z}} - \frac{(qx)^{N+1}}{1-\frac{z}{x}} = -q^{N+1}(z^{N+1} + z^N x + \cdots + zx^N + x^{N+1}). \quad (3.46)$$

How to realize the cancellation between three patches, including  $Y = 0$ ? In fact, the summation over three patches also becomes the Weyl character formula of  $U(3)_R$ :

$$-\frac{(qx)^{N+1}}{(1-\frac{y}{x})(1-\frac{z}{x})} - \frac{(qy)^{N+1}}{(1-\frac{z}{y})(1-\frac{x}{y})} - \frac{(qz)^{N+1}}{(1-\frac{x}{z})(1-\frac{y}{z})} = -q^{N+1}\chi_{(N+1,0)}^{U(3)_R}(x, y, z). \quad (3.47)$$

Here we include all zero modes to respect the  $U(3)_R$  symmetry between  $x, y, z$ .

Now the formula of the finite  $N$  corrections to the BPS partition function is the summation of each wrapped D3-brane BPS partition function over the three patches:

$$Z_1^{\text{D3}} = Z_{X=0}^{\text{D3}} + Z_{Y=0}^{\text{D3}} + Z_{Z=0}^{\text{D3}}. \quad (3.48)$$

We expect that this must give the finite  $N$  corrections to the BPS partition function coming from the single wrapped D3-brane configurations. Likewise, in the evaluation of the classical energy in the single wrapped D3-brane case, the classical energy of the double wrapping configuration is  $2N$  in the unit of the AdS radius, the contribution to the BPS partition function starts from  $\mathcal{O}(q^{2N})$ . Note that this evaluation is just the estimation. There may be a contribution from tachyonic terms as in the single wrapping case, and the first contribution of the double wrapping configurations may be a higher power than  $q^{2N}$ .

Now the finite  $N$  BPS partition function up to the single wrapping on the AdS side is given by

$$Z_N^{\text{AdS}} = Z_{\text{BPS}}^{\text{KK}}(1 + Z_1^{\text{D3}}), \quad (3.49)$$

where we do not include the higher wrapping than the single wrapping. We expect that the formula (3.49) is valid up to  $\mathcal{O}(q^{2N+\delta_2})$ , where  $\delta_2$  is an effect of tachyonic terms on the double wrapping.

Let us confirm the validity of this formula for small ranks,  $N = 1, 2$ . For simplicity, we set  $x = y = z = 1$  in the definition (3.17), or  $x = y = z = q$  in (2.28). On the CFT side, expanding (2.48) and (2.49) up to some orders, we find

$$Z_{U(1)}^{\text{CFT}} = 1 + 3q + 6q^2 + 10q^3 + 15q^4 + 21q^5 + 28q^6 + 36q^7 + \mathcal{O}(q^8), \quad (3.50)$$

$$\begin{aligned} Z_{U(2)}^{\text{CFT}} &= 1 + 3q + 12q^2 + 28q^3 + 66q^4 + 126q^5 + 236q^6 \\ &\quad + 396q^7 + 651q^8 + 1001q^9 + \mathcal{O}(q^{10}). \end{aligned} \quad (3.51)$$

On the other hand, our formula (3.49) gives

$$Z_{N=1}^{\text{AdS}} = (\cdots \text{identical terms with (3.50)} \cdots) - 216q^7 + \mathcal{O}(q^8), \quad (3.52)$$

$$Z_{N=2}^{\text{AdS}} = (\cdots \text{identical terms with (3.51)} \cdots) + 539q^9 + \mathcal{O}(q^{10}). \quad (3.53)$$

From this comparison, we find  $\delta_2 = 5$ . A detail analysis suggests that  $\delta_n$  may be given by  $\frac{1}{2}n(n+3)$  for the  $\frac{1}{8}$ -BPS sector. Thus, our formula indeed gives the correct finite  $N$  corrections up to the expected order. Although we could go on to the multiple wrapping, next, we will apply the analysis for the single wrapping to the superconformal index.

Before the ending of this section, there are some comments for other BPS sectors. In fact, the analysis for  $\frac{1}{2}$ -BPS and  $\frac{1}{4}$ -BPS sectors immediately obtained by setting  $x = y = 0$  and  $z = 0$ , respectively. The effect of tachyonic terms may become  $\delta_n = \frac{1}{2}n(n+1)$  and  $\frac{1}{2}n(n+2)$  for the  $\frac{1}{2}$ -BPS and  $\frac{1}{4}$ -BPS sectors. It is worthwhile to mention that the analysis for the  $\frac{1}{2}$ -BPS sector can be done in all orders of the fugacity, including the all wrapped D3-branes. Hence we can exactly show that  $\delta_n = \frac{1}{2}n(n+1)$  for the  $\frac{1}{2}$ -BPS sector.

## 3.2 Superconformal index

This section aims to reproduce the superconformal index of the  $\mathcal{N} = 4$   $U(N)$  SYM by considering wrapped D3-branes on the AdS side, as we did in the last section for the BPS partition function. We will calculate the finite  $N$  corrections to the superconformal index by using the same technique in the previous section.

In the last chapter, we first calculated the BPS partition function on the AdS side. Then only KK modes contributed to the BPS partition function. On the other hand, there were contributions from not only the KK modes but also their superpartners in the case of the superconformal index. Thus, in order to include all the contributions to the superconformal, what we have to do is to perform the supersymmetric completion of the primary scalar modes.

### 3.2.1 Supersymmetry on wrapped D3-branes

Let us consider the  $Z = 0$  configuration of the wrapped D3-brane as in the BPS partition function. According to the Mikhailov discussion [36], this configuration is  $\frac{1}{2}$ -BPS. We give the conserved supercharges for  $Z = 0$  as well as  $X = 0$  and  $Y = 0$  in Table 3.1.

The  $\mathcal{N} = 4$  supersymmetry is partially broken on the wrapped D3-brane  $Z = 0$ . In particular, there is no  $P$  and  $K$  symmetries. The  $SO(6)$   $R$ -symmetry is also broken to  $SO(4)_{XY} \times SO(2)_Z = SU(2)_R \times SU(2)_{\bar{R}} \times U(1)_Z$  because of a choice of the  $Z = 0$  configuration. The Cartan generators are

$$R = \frac{1}{2}(R_X - R_Y), \quad \bar{R} = \frac{1}{2}(R_X + R_Y), \quad R_Z, \quad (3.54)$$

respectively. The supercharge quartet of  $SO(6)_R$  is then broken to two doublets of  $SU(2)_R$

Configurations	Supercharges
$X = 0$	$Q^{3,4}, \bar{Q}_{1,2}$
$Y = 0$	$Q^{2,4}, \bar{Q}_{1,3}$
$Z = 0$	$Q^{2,3}, \bar{Q}_{1,4}$

Table 3.1 The preserved supercharges on  $X = 0$ ,  $Y = 0$ , and  $Z = 0$  configurations of the wrapped D3-brane, respectively. Due to the loss of part of supercharges in the  $\mathcal{N} = 4$  superalgebra, we have no longer  $P$  and  $K$  symmetries on the wrapped D3-brane.

$Q^I$ and $\bar{Q}_I$	$R_X$	$R_Y$	$R_Z$	$R$	$\bar{R}$
$Q^4$	$\frac{1}{2}$	$\frac{1}{2}$	$-\frac{1}{2}$	0	$\frac{1}{2}$
$Q^3$	$\frac{1}{2}$	$-\frac{1}{2}$	$\frac{1}{2}$	$\frac{1}{2}$	0
$Q^2$	$-\frac{1}{2}$	$\frac{1}{2}$	$\frac{1}{2}$	$-\frac{1}{2}$	0
$Q^1$	$-\frac{1}{2}$	$-\frac{1}{2}$	$-\frac{1}{2}$	0	$-\frac{1}{2}$
$\bar{Q}_1$	$\frac{1}{2}$	$\frac{1}{2}$	$\frac{1}{2}$	0	$\frac{1}{2}$
$\bar{Q}_2$	$\frac{1}{2}$	$-\frac{1}{2}$	$-\frac{1}{2}$	$\frac{1}{2}$	0
$\bar{Q}_3$	$-\frac{1}{2}$	$\frac{1}{2}$	$-\frac{1}{2}$	$-\frac{1}{2}$	0
$\bar{Q}_4$	$-\frac{1}{2}$	$-\frac{1}{2}$	$\frac{1}{2}$	0	$-\frac{1}{2}$

Table 3.2 The  $R$ -charges of supercharges. From this, we can find that  $(Q^2, Q^3)$  form a doublet in  $SU(2)_R$  with  $R_Z = \frac{1}{2}$  and  $(\bar{Q}_1, \bar{Q}_4)$  form a doublet in  $SU(2)_{\bar{R}}$  with  $R_Z = \frac{1}{2}$  on  $Z = 0$  configuration. The plus sign of the  $R_Z$  charge is consistent because  $Z = 0$  is not an anti-holomorphic surface but a holomorphic surface.

and  $SU(2)_{\bar{R}}$  as

$$Q_\alpha^I : \bar{4} \in SO(6)_R \rightarrow (2, 1)_{\frac{1}{2}} \oplus (1, 2)_{-\frac{1}{2}} \in SU(2)_R \times SU(2)_{\bar{R}} \times U(1)_Z. \quad (3.55)$$

We summarize  $R$ -charges of supercharges in Table 3.2.

Let  $A$  and  $\dot{A}$  be the indices of  $SU(2)_R$  and  $SU(2)_{\bar{R}}$ , respectively. We define

$$Q_\alpha^A = (Q_\alpha^{A=1}, Q_\alpha^{A=2}) = (Q_\alpha^{I=2}, Q_\alpha^{I=3}), \quad (3.56a)$$

$$\bar{Q}_{\dot{A}}^\alpha = (\bar{Q}_{\dot{A}=1}^\alpha, \bar{Q}_{\dot{A}=2}^\alpha) = (\bar{Q}_{I=1}^\alpha, \bar{Q}_{I=4}^\alpha). \quad (3.56b)$$

Then the unbroken algebra among fermionic generators becomes

$$2\{S_A^\alpha, Q_\beta^B\} = \delta_\beta^\alpha \delta_A^B (H - R_Z) + 2\delta_A^B J^\alpha{}_\beta + 2\delta_\beta^\alpha R^B{}_A, \quad (3.57a)$$

$$2\{\bar{Q}_{\dot{A}}^\alpha, \bar{S}_{\dot{\beta}}^{\dot{B}}\} = \delta_{\dot{\beta}}^\alpha \delta_{\dot{A}}^{\dot{B}} (H - R_Z) - 2\delta_{\dot{A}}^{\dot{B}} \bar{J}^{\dot{\alpha}}{}_{\dot{\beta}} - 2\delta_{\dot{\beta}}^\alpha \bar{R}^{\dot{B}}{}_{\dot{A}}. \quad (3.57b)$$

This can be derived from  $\mathcal{N} = 4$  supersymmetry algebra (2.51) by restricting the supercharges to those on  $Z = 0$  configuration.

In the algebra (3.57), we can obtain the bounds

$$2\{S_{A=2}^{\alpha=2}, Q_{\beta=2}^{B=2}\} = E - 2j_L - (2R + R_Z) \geq 0, \quad (3.58)$$

$$2\{\bar{Q}_{\dot{A}=1}^{\dot{\alpha}=1}, \bar{S}_{\dot{\beta}=1}^{\dot{B}=1}\} = E - 2j_R - (2\bar{R} + R_Z) \geq 0, \quad (3.59)$$

The lower bound (3.59) is the same as our BPS bound (2.53), if we rewrite the  $R$ - and  $\bar{R}$ -charges by (3.54). So we construct a representation starting from the primary scalar mode. Since we have already seen that the modes  $\bar{\phi}^{(l)}$  indeed reproduce the BPS partition function in the finite  $N$  region, it turns out that these modes correspond to the primary scalar operators on the CFT side. On the AdS side,  $\bar{\phi}^{(l)}$  should also be the superconformal primary of the superconformal algebra. Thus we can construct a representation of the algebra (3.57) starting from  $\bar{\phi}^{(l)}$ .

### 3.2.2 Superconformal index of wrapped D3-brane

Since we have obtained the symmetry algebra (3.57), we can construct a representation of modes on the wrapped D3-brane to find the superconformal index. Since  $\bar{\phi}^{(l)}$  is the superconformal primary, it satisfies

$$[S_A^\alpha, \bar{\phi}^{(l)}] = [\bar{S}_{\dot{\alpha}}^{\dot{A}}, \bar{\phi}^{(l)}] = 0. \quad (3.60)$$

The superpartners are obtained by acting supercharges  $Q_\alpha^A$  and  $\bar{Q}_{\dot{A}}^{\dot{\alpha}}$  to this scalar mode. Let us adopt the notation  $[j_L, j_R]_E^{(R, \bar{R}, R_Z)}$  to represent these modes. Then we obtain

$$\bar{\phi}^{(l)} : [0, 0]_{l-1}^{(\frac{l}{2}, \frac{l}{2}, -1)} \xrightarrow{Q_\alpha^A} [\frac{1}{2}, 0]_{l-\frac{1}{2}}^{(\frac{l-1}{2}, \frac{l}{2}, -\frac{1}{2})} \oplus [\frac{1}{2}, 0]_{l-\frac{1}{2}}^{(\frac{l+1}{2}, \frac{l}{2}, -\frac{1}{2})}, \quad (3.61)$$

$$\bar{\phi}^{(l)} : [0, 0]_{l-1}^{(\frac{l}{2}, \frac{l}{2}, -1)} \xrightarrow{\bar{Q}_{\dot{A}}^{\dot{\alpha}}} [0, \frac{1}{2}]_{l-\frac{1}{2}}^{(\frac{l}{2}, \frac{l-1}{2}, -\frac{1}{2})} \oplus [0, \frac{1}{2}]_{l-\frac{1}{2}}^{(\frac{l}{2}, \frac{l+1}{2}, -\frac{1}{2})}. \quad (3.62)$$

The second representation in the right hand side actually corresponds a null state. Thus we have only the first representation. We denote these fermionic modes as  $\psi$  and  $\bar{\chi}$ . Namely, we find

$$\bar{\phi}^{(l)} \xrightarrow{Q_\alpha^A} \psi^{(l)} : [\frac{1}{2}, 0]_{l-\frac{1}{2}}^{(\frac{l-1}{2}, \frac{l}{2}, -\frac{1}{2})}, \quad \bar{\phi}^{(l)} \xrightarrow{\bar{Q}_{\dot{A}}^{\dot{\alpha}}} \bar{\chi}^{(l)} : [0, \frac{1}{2}]_{l-\frac{1}{2}}^{(\frac{l}{2}, \frac{l-1}{2}, -\frac{1}{2})}. \quad (3.63)$$

By repeating this process, we have a multiplet of the massless modes on the wrapped D3-brane  $Z = 0$ . We summarize all the modes in Table 3.3 and the structure of the multiplet in Fig. 3.1.

We have finished the classification of the massless modes on the wrapped D3-brane. Next, let us compute the single-particle index of the worldvolume theory on the wrapped

Modes	$E$	$[j_L]$	$[j_R]$	$[R]$	$[\bar{R}]$	$R_Z$
$\bar{\phi}^{(l)}$	$l-1$	0	0	$[\frac{l}{2}]$	$[\frac{l}{2}]$	-1
$\bar{\chi}^{(l)}$	$l-\frac{1}{2}$	0	$[\frac{1}{2}]$	$[\frac{l}{2}]$	$[\frac{l-1}{2}]$	$-\frac{1}{2}$
$\bar{F}^{(l)}$	$l$	0	0	$[\frac{l}{2}]$	$[\frac{l-2}{2}]$	0
$\psi^{(l)}$	$l-\frac{1}{2}$	$[\frac{1}{2}]$	0	$[\frac{l-1}{2}]$	$[\frac{l}{2}]$	$-\frac{1}{2}$
$w^{(l)}$	$l$	$[\frac{1}{2}]$	$[\frac{1}{2}]$	$[\frac{l-1}{2}]$	$[\frac{l-1}{2}]$	0
$\bar{\psi}^{(l)}$	$l+\frac{1}{2}$	$[\frac{1}{2}]$	0	$[\frac{l-1}{2}]$	$[\frac{l-2}{2}]$	$\frac{1}{2}$
$F^{(l)}$	$l$	0	0	$[\frac{l-2}{2}]$	$[\frac{l}{2}]$	0
$\chi^{(l)}$	$l+\frac{1}{2}$	0	$[\frac{1}{2}]$	$[\frac{l-2}{2}]$	$[\frac{l-1}{2}]$	$\frac{1}{2}$
$\phi^{(l)}$	$l+1$	0	0	$[\frac{l-2}{2}]$	$[\frac{l-2}{2}]$	1

Table 3.3 The massless modes arising in the worldvolume theory on the wrapped D3-brane  $Z = 0$ .  $[j]$  stands for a spin  $j$  representation of a corresponding  $SU(2)$ . Some of these modes saturate the BPS bound (3.59).

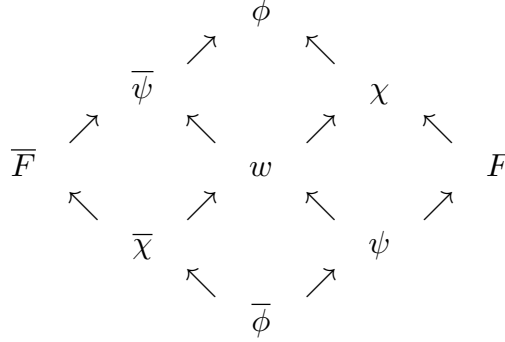

Fig. 3.1 The multiplet structure of the massless modes on the wrapped D3-brane  $Z = 0$ . The right diagonal up arrow stands for the action of  $Q_\alpha^A$ , and the left diagonal up arrow stands for the action of  $\bar{Q}_A^\alpha$ .

D3-brane. Here it is convenient to rewrite (2.52) in terms of  $R$  and  $\bar{R}$  as

$$\mathcal{I} = \text{tr}[(-1)^F \bar{x}^{\bar{\Delta}} q^{E+j_R} y^{2j_L} u^{2R} v^{\bar{R}-R-R_Z}]. \quad (3.64)$$

Then all we have to do is to sum up the contributions of the BPS modes of modes shown in Table 3.3. From this table, we find the BPS modes shown in Table 3.4.

The single-particle index obtained from Table 3.4 is

$$i_{\text{sp}}^{Z=0} = 1 - \frac{(1 - \frac{v}{q})(1 - yq^{\frac{3}{2}})(1 - y^{-1}q^{\frac{3}{2}})}{(1 - uq)(1 - \frac{v}{u}q)}. \quad (3.65)$$

This is just the index of a  $U(1)$  theory realized on the  $Z = 0$  wrapped D3-brane. Thus

$[j_L, j_R]_E^{(R, \bar{R}, R_Z)}$	Condition	Range of $R$	Contribution
$[0, 0]_{l-1}^{([\frac{l}{2}], \frac{l}{2}, -1)}$	$l \geq 0$	$-\frac{l}{2} \rightarrow \frac{l}{2}$	$q^{l-1} u^{2R} v^{\frac{l}{2}-R+1}$
$[0, \frac{1}{2}]_{l-\frac{1}{2}}^{([\frac{l}{2}], \frac{l-1}{2}, -\frac{1}{2})}$	$l \geq 1$	$-\frac{l}{2} \rightarrow \frac{l}{2}$	$-q^l u^{2R} v^{\frac{l-1}{2}-R+\frac{1}{2}}$
$[[\frac{1}{2}], 0]_{l-\frac{1}{2}}^{([\frac{l-1}{2}], \frac{l}{2}, -\frac{1}{2})}$	$l \geq 1$	$-\frac{l-1}{2} \rightarrow \frac{l-1}{2}$	$-q^{l-\frac{1}{2}} \chi_1^J u^{2R} v^{\frac{l}{2}-R+\frac{1}{2}}$
$[[\frac{1}{2}], \frac{1}{2}]_l^{([\frac{l-2}{2}], \frac{l-1}{2}, 0)}$	$l \geq 1$	$-\frac{l-1}{2} \rightarrow \frac{l-1}{2}$	$q^{l+\frac{1}{2}} \chi_1^J u^{2R} v^{\frac{l-1}{2}-R}$
$[0, 0]_l^{([\frac{l-2}{2}], \frac{l}{2}, 0)}$	$l \geq 2$	$-\frac{l-2}{2} \rightarrow \frac{l-2}{2}$	$q^l u^{2R} v^{\frac{l}{2}-R}$
$[0, \frac{1}{2}]_{l+\frac{1}{2}}^{([\frac{l-2}{2}], \frac{l-1}{2}, \frac{1}{2})}$	$l \geq 2$	$-\frac{l-2}{2} \rightarrow \frac{l-2}{2}$	$-q^{l+1} u^{2R} v^{\frac{l-1}{2}-R-\frac{1}{2}}$

Table 3.4 The BPS massless modes arising on the wrapped D3-brane. Summing up all contributions shown here, we find the single-particle index for the fluctuations of the wrapped D3-brane  $Z = 0$ .

the multi-particle index is the plethystic exponential of (3.65):

$$\mathcal{I}_{Z=0}^{\text{D3}} = (v^{-1}q)^N \text{Pexp}(i_{\text{sp}}^{Z=0}), \quad (3.66)$$

where the factor  $(v^{-1}q)^N$  is the classical contribution obtained by (3.29) and (3.30). Again, we have a tachyonic mode and zero modes in the single-particle index as in the case of the BPS partition function:

$$i_{\text{sp}} = \frac{1}{v^{-1}q} + \left( \frac{u}{v^{-1}} + \frac{u^{-1}v}{v^{-1}} \right) + \mathcal{O}(q^{\frac{1}{2}}). \quad (3.67)$$

Actually, these modes come from the modes  $l = 0, 1$  in  $[0, 0]_{l-1}^{([\frac{l}{2}], \frac{l}{2}, -1)}$  shown in the first line of Table 3.4. Since these modes contributed to the BPS partition function, the situation is the exactly same as the BPS partition function (3.39). Hence we take the analytic continuation for the tachyonic mode,

$$\text{Pexp} \left( \frac{1}{v^{-1}q} \right) = \frac{1}{1 - (v^{-1}q)^{-1}} = -\frac{v^{-1}q}{1 - v^{-1}q} = -v^{-1}q \text{Pexp}(v^{-1}q) \quad (3.68)$$

as (3.40), and perform the Weyl completion

$$\mathcal{I}^{\text{D3}} = \mathcal{I}_{X=0}^{\text{D3}} + \mathcal{I}_{Y=0}^{\text{D3}} + \mathcal{I}_{Z=0}^{\text{D3}}. \quad (3.69)$$

Note that this summation becomes the Weyl character formula of the  $SU(3)_R$  character.

We expect that (3.69) gives the first non-trivial finite  $N$  corrections to the index on the AdS side. Since we only consider the single wrapped D3-branes, there should be the error coming from the double wrapping contributions. The energy of D3-branes of double

wrapping is about  $2N$ . Then the index on the AdS side is

$$\mathcal{I}_N^{\text{AdS}} = \mathcal{I}^{\text{KK}}(1 + \mathcal{I}^{\text{D3}}) + \mathcal{O}(q^{2N}). \quad (3.70)$$

We conjecture that this index is equivalent to that on the CFT side, namely

$$\mathcal{I}_{U(N)}^{\text{CFT}} = \mathcal{I}^{\text{KK}}(1 + \mathcal{I}^{\text{D3}}) + \mathcal{O}(q^{2N}), \quad (3.71)$$

where  $\mathcal{I}_{U(N)}^{\text{CFT}}$  is given by (2.58).

### 3.2.3 Comparison with the CFT side

Let us consider the comparison with the CFT side to check the correctness of our formula (3.70) for  $N = 1, 2, 3$ . The results on the CFT side was already given in (2.59), (2.60) and (2.61). Comparing these results with our formula (3.70), we find

$$\begin{aligned} \mathcal{I}_{N=1}^{\text{AdS}} &= (\dots \text{identical terms with (2.59)} \dots) \\ &\quad + 2(1 + \chi_{(2,2)} + \chi_{(6,0)})q^6 + \mathcal{O}(q^{\frac{13}{2}}), \end{aligned} \quad (3.72)$$

$$\begin{aligned} \mathcal{I}_{N=2}^{\text{AdS}} &= (\dots \text{identical terms with (2.60)} \dots) \\ &\quad + 2(\chi_{(0,4)} + \chi_{(2,0)} + \chi_{(4,2)} + \chi_{(8,0)})q^8 + \mathcal{O}(q^{\frac{17}{2}}), \end{aligned} \quad (3.73)$$

$$\begin{aligned} \mathcal{I}_{N=3}^{\text{AdS}} &= (\dots \text{identical terms with (2.61)} \dots) \\ &\quad + 2(\chi_{(0,2)} + \chi_{(2,4)} + \chi_{(4,0)} + \chi_{(6,2)} + \chi_{(10,0)})q^{10} + \mathcal{O}(q^{\frac{21}{2}}). \end{aligned} \quad (3.74)$$

These results are consistent with our conjecture (3.71). Furthermore, the results suggest that the relation of the index between the CFT side and the AdS side is

$$\mathcal{I}_{U(N)}^{\text{CFT}} = \mathcal{I}^{\text{KK}}(1 + \mathcal{I}^{\text{D3}}) + \mathcal{O}(q^{2N+4}) \quad (3.75)$$

rather than (3.71). The shift  $q^{2N} \rightarrow q^{2N+4}$  of the error may be interpreted as the effect of the tachyonic modes in the double wrapping contributions. Let us consider the specific configuration given by  $Z^2 = 0$  as an example of a double wrapping configuration. Roughly speaking, the finite  $N$  corrections coming from this configuration is the  $U(2)$  index with the single-particle index (3.65). Thus we have

$$\begin{aligned} \mathcal{I}_{Z^2=0}^{\text{D3}} &= (v^{-1}q)^{2N} \oint_{|z|=1} \frac{dz}{2\pi iz} \text{Pexp}[i_{\text{sp}}^{Z=0}(z^{-1} + 2 + z)] \\ &\sim \oint_{|z|=1} \frac{dz}{2\pi iz} \frac{(v^{-1}q)^{2N}}{(1 - \frac{1}{v^{-1}q})^2(1 - \frac{1}{v^{-1}q}z)(1 - \frac{1}{v^{-1}q}z^{-1})} \dots \sim (v^{-1}q)^{2N+4} + \dots, \end{aligned} \quad (3.76)$$

and this is consistent with the shift  $q^{2N} \rightarrow q^{2N+4}$ .

---

In summary, we confirmed that our formula (3.69) and (3.70) does work at least for  $N = 1, 2, 3$ , up to the double wrapping configurations. We expect that the formula works even for arbitrary  $N$ . In the next chapter, we apply the formula to the S-fold theories to find the BPS partition function and the superconformal index.



## Chapter 4

# Four-Dimensional S-fold Theories

It is well known that any  $\mathcal{N} = 3$  theories that have the weak coupling limit automatically have the  $\mathcal{N} = 4$  supersymmetry. Then, an  $\mathcal{N} = 3$  theory that never has the  $\mathcal{N} = 4$  supersymmetry is called a genuine  $\mathcal{N} = 3$  theory. In the paper [38], Aharony and Evtikhiev discussed some properties of genuine  $\mathcal{N} = 3$  theories under the assumption that genuine  $\mathcal{N} = 3$  theories exist. After their work, Garcia-Etxebarria and Regalado discovered explicit examples of genuine  $\mathcal{N} = 3$  theories [18] as a generalization of the orientifold theory. We call these theories S-fold theories following [20].

In this chapter, we investigate the S-fold theories by using the AdS/CFT correspondence. In particular, we compute the BPS partition function and the superconformal index following the author's and his collaborators' papers [22, 23]. Since the S-fold theories have no weak coupling limit, namely no marginal deformation, we cannot use the free field counting. Alternatively, we use the method developed in the last chapter to calculate the finite  $N$  corrections to the index. After the calculation, we do the consistency check. It was conjectured in [20] that some of the S-fold theories are equivalent to  $\mathcal{N} = 4$  SYM with a certain gauge group. Then we can compare our result with that of the corresponding  $\mathcal{N} = 4$  SYM. Also, recently Zafrir found the UV Lagrangian for some of the S-fold theories and calculated the index [21]. So we compare our results with Zafrir's result.

### 4.1 $\mathcal{N} = 4$ orientifold theory

Before discussing the S-fold theories, we would like to review the orientifold and the AdS/CFT correspondence regarding the orientifold.

An orientifold action in type II string theory is defined by  $I \cdot \Omega \cdot J$ , where  $I$  is the sign flip of coordinates of  $\mathbb{R}^{9-p}$ ,  $\Omega$  is the orientation reversal of the worldsheet of strings, and  $J$  is the fermion number operator  $(-1)^{F_L}$  of left moving spacetime fermions for  $p = 2, 3, 6, 7$ , otherwise the identity operator. Then an orientifold  $p$ -plane ( $Op$ -plane) is defined as a fixed plane under the orientifold action. In other words, an  $Op$ -plane is a  $p+1$ -dimensional

plane of type II string theory on  $\mathbb{R}^{1,p} \times \mathbb{R}^{9-p}/(I \cdot \Omega \cdot J)$ . We consider the  $p = 3$  case here.

Let us see the orientifold action for  $p = 3$  in more detail. We consider an O3-plane is embedded in  $\mathbb{R}^{1,3} \times \mathbb{C}^3$ , where  $\mathbb{C}^3$  is orthogonal to the O3-plane. Unlike the orbifold, the orientifold acts on fields as well as coordinates. First, the orientifold acts on the transverse coordinates  $X, Y, Z \in \mathbb{C}^3$  as

$$(X, Y, Z) \rightarrow (-X, -Y, -Z). \quad (4.1)$$

Since  $SO(6)_R$  is the rotation symmetry of the transverse direction of D3-branes, this transformation can be realized by  $-1 \in SO(6)_R$ .

Second, the orientifold acts on the massless fields in type IIB string theory as<sup>\*1</sup>

$$\begin{pmatrix} C_2 \\ B_2 \end{pmatrix} \rightarrow \begin{pmatrix} -C_2 \\ -B_2 \end{pmatrix}, \quad (4.2)$$

and other bosonic fields are invariant. Therefore, the orientifold action can be realized by taking  $M = -1$  in the  $SL(2, \mathbb{R})$  transformation (2.87). Note that if we take account of the flux quantization (2.75),  $SL(2, \mathbb{R})$  is broken to  $SL(2, \mathbb{Z})$ .

### 4.1.1 AdS/CFT correspondence in the orientifold background

The AdS/CFT correspondence in the presence of the O3-plane is first discussed by Witten [39]. To discuss it, we place  $N$  D3-branes parallel to O3-plane. The realized 4d theory on D3-branes should be invariant under the orientifold action. Since the orientifold action has the orientation reversal, we expect that the realized theory is  $\mathcal{N} = 4$  with the  $SO$  or  $Sp$  type gauge group. If we take the near horizon limit, the geometry becomes  $AdS_5 \times S^5/\mathbb{Z}_2$  due to the orientifold action (4.1).

Let  $H_3$  and  $F_3$  be the field strength of  $B_2$  and  $C_2$ , respectively. In the presence of the O3-plane,  $H_3$  and  $F_3$  are not globally defined 3-form fields but twisted 3-form fields. Then these twisted 3-form fields are classified by the twisted sheaf cohomology

$$H^3(S^5/\mathbb{Z}_2, \tilde{\mathbb{Z}} \oplus \tilde{\mathbb{Z}}) = \mathbb{Z}_2 \oplus \mathbb{Z}_2, \quad (4.3)$$

where  $\tilde{\mathbb{Z}}$  is a twisted sheaf of integers. This is called the discrete torsion of 3-form fields  $H_3$  and  $F_3$ . The realizable theories on  $N$  D3-branes are now classified by  $\mathbb{Z}_2 \oplus \mathbb{Z}_2$ .

Let us call the two types of discrete torsion  $\theta_{NS}$  and  $\theta_{RR}$ . The four possible models correspond to values

$$(\theta_{NS}, \theta_{RR}) = (0, 0), (1, 0), (0, 1), (1, 1). \quad (4.4)$$

It is clear that  $\theta_{NS}$  and  $\theta_{RR}$  form a doublet under  $SL(2, \mathbb{Z})$ . Then a model with

---

<sup>\*1</sup> The massless fields of type IIB string theory are listed in Table 2.7.

$(\theta_{\text{NS}}, \theta_{\text{RR}})$	Gauge group
(0, 0)	$SO(2N)$
(1, 0)	$Sp(N)$
(0, 1)	$SO(2N + 1)$
(1, 1)	$Sp(N)$

Table 4.1 A table of the classification of the discrete torsion  $(\theta_{\text{NS}}, \theta_{\text{RR}})$  with corresponding gauge groups.

$(\theta_{\text{NS}}, \theta_{\text{RR}}) = (0, 0)$  corresponds to the  $\mathcal{N} = 4$   $SO(2N)$  SYM because this theory is self dual under  $SL(2, \mathbb{Z})$  (known as the Montonen-Olive duality [40]). Other models can also be classified in this way. We summarized the correspondence between  $(\theta_{\text{NS}}, \theta_{\text{RR}})$  and the gauge group in Table 4.1.

In summary, we have found the following AdS/CFTs [39]:

$$4d \mathcal{N} = 4 \text{ } SO, Sp \text{ gauge theory} \iff \text{Type IIB string theory on } AdS_5 \times S^5 / \mathbb{Z}_2. \quad (4.5)$$

### Pfaffian operators and wrapped D3-branes

In Chapter 3, we analyzed wrapped D3-branes on three-cycle in  $S^5$ , and they indeed gave the finite  $N$  corrections to the BPS partition function and the superconformal index. In the orientifold theory, these wrapped D3-branes also have an essential role in finding the finite  $N$  corrections.

Actually, Witten pointed out that a Pfaffian operator on the CFT side corresponds to a wrapped D3-brane on a non-trivial three-cycle in  $S^5 / \mathbb{Z}_2$  [39]. The Pfaffian operator is defined as  $N$  adjoint scalars contracted by an epsilon tensor. In the  $\mathcal{N} = 4$   $SO(2N)$  SYM, this is given by

$$\text{Pf}(\Phi) = \frac{1}{N!} \epsilon_{i_1 \dots i_{2N}} (\Phi)_{i_1 i_2} \dots (\Phi)_{i_{2N-1} i_{2N}}, \quad (4.6)$$

where  $\Phi$  is one of the adjoint scalars  $X, Y, Z$ . It is possible to generalize this definition, including different types of fields, for example,  $\epsilon XY \dots Z$ . Then we refer to this type of operator as the Pfaffian type operator. We can also consider the composite operators of Pfaffians and trace operators. From the definition (4.6), it turns out that the Pfaffian operators exist only for  $\mathcal{N} = 4$   $SO(2N)$  SYM.

Note that the square of the Pfaffian operator is the determinant operator<sup>\*2</sup>:  $\text{Pf}(\Phi) \propto \det \Phi$ . This is reminiscent of  $\mathbb{Z}_2$  structure. In fact, the wrapped D3-branes on three-cycle

<sup>\*2</sup> As we pointed out in subsection 2.1.3, the determinant operators can be written by trace operators.

in  $S^5/\mathbb{Z}_2$  are classified by the third homology group

$$H_3(S^3/\mathbb{Z}_2, \mathbb{Z}) = \mathbb{Z}_2. \quad (4.7)$$

Its charge is called the winding number (mod 2) of the wrapped D3-brane.

As a final comment in this subsection, the wrapped D3-branes on trivial cycles are always present because they correspond to the trace operators on the CFT side [19]. For example, the double wrapping is allowed to exist because they have a trivial charge of  $H_3(S^5/\mathbb{Z}_2, \mathbb{Z}) = \mathbb{Z}_2$ . This implies that the first non-trivial finite  $N$  corrections come from the double wrapping for  $\mathcal{N} = 4$   $SO(2N+1)$  and  $Sp(N)$  SYMs. This is beyond our purpose in this thesis, and we leave it for future work.

### 4.1.2 BPS partition function

Now, we give a short explanation about the BPS partition function of the interacting  $\mathcal{N} = 4$   $SO(N)$  and  $Sp(N)$  SYMs. The calculation on the AdS side will be given later.

#### $\frac{1}{2}$ -BPS partition function

First let us consider the  $\frac{1}{2}$ -BPS partition function. The single-particle  $\frac{1}{2}$ -BPS partition function is given by the Coulomb branch operators of the theory, namely the Casimir operators. The Casimir operators of  $SO(2N+1)$  and  $Sp(N)$  group have a conformal dimension  $2, 4, \dots, 2N$ . They correspond to the  $\frac{1}{2}$ -BPS operators  $\{\text{Tr}Z^{2n} | n = 1, \dots, N\}$ . Thus the  $\frac{1}{2}$ -BPS partition function is

$$Z_{SO(2N+1)}^{\frac{1}{2}\text{-BPS}}(z) = Z_{Sp(N)}^{\frac{1}{2}\text{-BPS}}(z) = \text{Pexp} \left( \sum_{n=1}^N x^{2n} \right) = \prod_{n=1}^N \frac{1}{1 - x^{2n}}. \quad (4.8)$$

The equality of  $SO(2N+1)$  and  $Sp(N)$  is consistent with the  $SL(2, \mathbb{Z})$  duality. This result is the same as the  $U(N)$   $\frac{1}{2}$ -BPS partition function with the replacement  $z \rightarrow z^2$ . Therefore, the grand partition function is also obtained by the same replacement for (2.47) as follows:

$$\Xi_{SO(\text{odd})}^{\frac{1}{2}\text{-BPS}}(z; t) = \Xi_{U(*)}^{\frac{1}{2}\text{-BPS}}(z^2; t) = \prod_{n=0}^{\infty} \frac{1}{1 - tz^{2n}} \equiv \text{Pexp} \left( I_{m=0}^{\mathbb{Z}_2}(z)t \right), \quad (4.9)$$

where the single-particle grand partition function  $I_{m=0}^{\mathbb{Z}_2}$  is given by

$$I_{m=0}^{\mathbb{Z}_2}(z) = \frac{1}{1 - z^2} = \frac{1}{2} \left( \frac{1}{1 - z} + \frac{1}{1 + z} \right). \quad (4.10)$$

On the other hand,  $\mathcal{N} = 4$   $SO(2N)$  SYM has not only trace operators but also a Pfaffian operator  $\text{Pf}(Z)$ , the conformal dimension of them are  $2, 4, \dots, 2N - 2$  and  $N$ . Note that the trace operator  $\text{Tr}Z^{2N}$  is constructed by  $\text{Pf}(Z)^2$ , it is not the independent operator,

and we do not consider it. Then the  $\frac{1}{2}$ -BPS partition function is obtained by removing a factor  $(1 - x^{2N})^{-1}$  and multiplying a factor  $(1 - x^N)^{-1}$  to (4.8). Thus we have

$$Z_{SO(2N)}^{\frac{1}{2}\text{-BPS}}(z) = \frac{1 - x^{2N}}{1 - x^N} Z_{SO(2N+1)}^{\frac{1}{2}\text{-BPS}}(z) = (1 + x^N) Z_{SO(2N+1)}^{\frac{1}{2}\text{-BPS}}(z). \quad (4.11)$$

The latter part,  $x^N Z_{SO(2N+1)}^{\frac{1}{2}\text{-BPS}}(z)$ , is the contributions from the Pfaffian type operators.  $x^N$  is the contribution from  $\text{Pf}(\mathbf{Z})$  and  $Z_{SO(2N+1)}^{\frac{1}{2}\text{-BPS}}(z)$  receives the contributions from other trace operators. Now we can immediately find the grand partition function from (4.9):

$$\begin{aligned} \Xi_{SO(\text{even})}^{\frac{1}{2}\text{-BPS}}(z; t) &= \sum_{N=0}^{\infty} Z_{SO(2N)}^{\frac{1}{2}\text{-BPS}}(z) t^N = \sum_{N=0}^{\infty} (1 + x^N) Z_{SO(2N+1)}^{\frac{1}{2}\text{-BPS}}(z) t^N \\ &= \Xi_{SO(\text{odd})}^{\frac{1}{2}\text{-BPS}}(z; t) + \Xi_{SO(\text{odd})}^{\frac{1}{2}\text{-BPS}}(z; zt) \equiv \text{Pexp}(I_{m=0}^{\mathbb{Z}_2}(z)t) + \text{Pexp}(I_{m=1}^{\mathbb{Z}_2}(z)t), \end{aligned} \quad (4.12)$$

where

$$I_{m=1}^{\mathbb{Z}_2}(z) = \frac{z}{1 - z^2} = \frac{1}{2} \left( \frac{1}{1 - z} - \frac{1}{1 + z} \right). \quad (4.13)$$

In summary, the  $\frac{1}{2}$ -BPS partition function can be unified into the following form

$$\Xi_{SO(*)}^{\frac{1}{2}\text{-BPS}}(z; t) = \sum_{pm=0} \text{Pexp}(I_m^{\mathbb{Z}_2}(z)t), \quad (4.14)$$

where  $m = 0, 1$ .  $p = 0$  corresponds to the trivial discrete torsion, and  $p = 1$  corresponds to the non-trivial torsion.

### $\frac{1}{8}$ -BPS partition function

Next, let us consider the  $\frac{1}{8}$ -BPS partition function. In the interacting theory, we can find the  $\frac{1}{8}$ -BPS partition function by considering the chiral ring. Then, all the adjoint scalars are commutable, and they are valued in the Cartan subgroup of the gauge group. Thus the  $\frac{1}{8}$ -BPS partition function should be the invariant series under the Weyl group.

First, let us see the  $SO(2N + 1)$  case. Then we choose the Cartan basis as

$$\mathbf{X} = \text{diag}(ix_1\sigma_2, \dots, ix_N\sigma_2, 0), \quad \sigma_2 = \begin{pmatrix} 0 & -i \\ i & 0 \end{pmatrix}, \quad (4.15)$$

where the last component 0 is a  $1 \times 1$  block matrix and others are  $2 \times 2$  block matrices.  $\mathbf{Y}$  and  $\mathbf{Z}$  have the same structure. The Weyl transformation contains a sign flip  $x_k \rightarrow -x_k$  ( $k = 1, \dots, N$ ) as well as the permutation of  $x_k$ 's. This sign flip is realized by  $SO(3) \subset$

$SO(2N + 1)$ , whose action is

$$\begin{pmatrix} & x_k & \\ -x_k & & \\ & & 0 \end{pmatrix} \xrightarrow{SO(3)} \begin{pmatrix} & -x_k & \\ x_k & & \\ & & 0 \end{pmatrix}. \quad (4.16)$$

To make the BPS partition function invariant under this sign flip and the permutation, we modify the single grand particle index of  $U(N)$  theory  $I(x, y, z)$  as follows:

$$I(x, y, z) \rightarrow \frac{1}{2}(I(x, y, z) + I(-x, -y, -z)) \equiv I_{m=0}^{\mathbb{Z}_2}(x, y, z). \quad (4.17)$$

Then the grand partition function is

$$\Xi_{SO(\text{odd})}^{\frac{1}{8}\text{-BPS}}(x, y, z; t) = \text{Pexp}(I_0^{\mathbb{Z}_2}(x, y, z)t). \quad (4.18)$$

When  $x = y = 0$ , it reproduces the  $\frac{1}{2}$ -BPS grand partition function of  $\mathcal{N} = 4$   $SO(2N + 1)$  SYM. The  $\frac{1}{8}$ -BPS partition function of  $Sp(N)$  is the same as (4.18).

Next let us see the  $SO(2N)$  case. In this case, the Cartan valued adjoint scalar fields are given by removing the last zero component from (4.15). Thus, there is no longer an  $SO(3)$  transformation like (4.16). However, we can perform an  $SO(4)$  transformation whose action is

$$(x_k, x_l) \rightarrow (-x_k, -x_l) \quad (4.19)$$

for arbitrary  $x_k$  and  $x_l$  with  $k \neq l$ . Since this transformation flips the sign of two variables simultaneously, the single-particle grand partition function does not have to be invariant under (4.19). Therefore, in addition to  $I_{m=0}^{\mathbb{Z}_2}$ , we can consider

$$I_{m=1}^{\mathbb{Z}_2} = \frac{1}{2}(I(x, y, z) - I(-x, -y, -z)). \quad (4.20)$$

So we find the  $\frac{1}{8}$ -BPS partition function for  $\mathcal{N} = 4$   $SO(2N)$  SYM:

$$\Xi_{SO(\text{even})}^{\frac{1}{8}\text{-BPS}}(x, y, z; t) = \text{Pexp}(I_0^{\mathbb{Z}_2}(x, y, z)t) + \text{Pexp}(I_1^{\mathbb{Z}_2}(x, y, z)t). \quad (4.21)$$

Again, setting  $x = y = 0$ , it reproduces the  $\frac{1}{2}$ -BPS grand partition function (4.12).

In summary, similarly to the  $\frac{1}{2}$ -BPS grand partition function (4.14), we can write the  $\frac{1}{8}$ -BPS partition function for  $\mathcal{N} = 4$   $SO(N)$  and  $Sp(N)$  SYMs as

$$\Xi_{SO(*)}^{\frac{1}{8}\text{-BPS}}(x, y, z; t) = \sum_{pm=0} \text{Pexp}(I_m^{\mathbb{Z}_2}(x, y, z)t). \quad (4.22)$$

The large  $N$  limit of the BPS partition function can be obtained by the formula (2.99).

The result is

$$Z_{SO(\infty)}^{\frac{1}{8}\text{-BPS}}(x, y, z) = \text{Pexp}(I_0^{\mathbb{Z}_2}(x, y, z) - 1). \quad (4.23)$$

It seems that the  $I_{m=1}^{\mathbb{Z}_2}$  is absent in the large  $N$  limit. The reason is as follows. In the large  $N$  limit, the number of indices in the epsilon tensor is infinite. So we cannot define the Pfaffian operators. In other words, the conformal dimension of the Pfaffian operator is of order  $N$ . Then they decouple from the BPS partition function in  $N \rightarrow \infty$ . That is why the corresponding term  $I_{m=1}^{\mathbb{Z}_2}$  does not appear. This is consistent because the wrapped D3-branes are not the physical objects in the large  $N$  limit because their mass is of order  $N$ .

### Consistency check

Before going on, let us do a consistency check of our result (4.22). This can be done by using the group theory isomorphisms. We know the following isomorphisms:

$$SO(2) \simeq U(1), \quad SO(3) \simeq SU(2), \quad SO(4) \simeq SU(2) \times SU(2), \quad SO(6) \simeq SU(4). \quad (4.24)$$

Thus the BPS partition functions should be the same as those of theories with these gauge groups. The BPS partition functions of these gauge theories are obtained by (4.22), and we can check the following facts:

$$Z_{SO(2)}^{\frac{1}{8}\text{-BPS}} = Z_{U(1)}^{\frac{1}{8}\text{-BPS}}, \quad Z_{SO(3)}^{\frac{1}{8}\text{-BPS}} = Z_{SU(2)}^{\frac{1}{8}\text{-BPS}}, \quad Z_{SO(4)}^{\frac{1}{8}\text{-BPS}} = (Z_{SU(2)}^{\frac{1}{8}\text{-BPS}})^2, \quad Z_{SO(6)}^{\frac{1}{8}\text{-BPS}} = Z_{SU(4)}^{\frac{1}{8}\text{-BPS}}. \quad (4.25)$$

### 4.1.3 Superconformal index

Let us consider the superconformal index for  $\mathcal{N} = 4$   $SO(N)$  SYM as well. The calculation of the index on the CFT side can be performed by the free field counting. The different point of the index from the  $\mathcal{N} = 4$   $U(N)$  SYM is only the gauge group. Thus, all we have to do is to replace the character of the adjoint representation and the Haar measure by those of  $SO(N)$ .

The characters of the adjoint representation of  $SO(2N)$  and  $SO(2N + 1)$  are given by

$$\chi_{\text{adj}}^{SO(2N)}(z_a) = N + \sum_{a \neq b} \frac{z_a}{z_b} + \sum_{a > b} \left( z_a z_b + \frac{1}{z_a z_b} \right), \quad (4.26)$$

$$\chi_{\text{adj}}^{SO(2N+1)}(z_a) = N + \sum_{a \neq b} \frac{z_a}{z_b} + \sum_{a > b} \left( z_a z_b + \frac{1}{z_a z_b} \right) + \sum_{a=1}^N \left( z_a + \frac{1}{z_a} \right), \quad (4.27)$$

where  $z_a$  ( $a = 1, \dots, N$ ) are the gauge fugacities. The Haar measure can be found from the formula (1.83).

For convenience, we give examples of the index up to rank three.

$$\begin{aligned}
\mathcal{I}_{SO(2)} &= 1 + \chi_{(1,0)} q - \chi_1^J q^{\frac{3}{2}} + (\chi_{(2,0)} - \chi_{(0,1)}) q^2 + (\chi_{(3,0)} - \chi_{(1,1)} + 1 - \chi_2^J) q^3 + \mathcal{O}(q^{\frac{7}{2}}), \\
\mathcal{I}_{SO(4)} &= 1 + 2\chi_{(2,0)} q^2 - 2\chi_1^J \chi_{(1,0)} q^{\frac{5}{2}} + (2 - 2\chi_{(1,1)}) q^3 + 2\chi_1^J (\chi_{(0,1)} + \chi_{(2,0)}) q^{\frac{7}{2}} \\
&\quad + (-2\chi_2^J \chi_{(1,0)} + \chi_{(0,2)} + \chi_{(2,1)} + 3\chi_{(4,0)}) q^4 - 4\chi_1^J (\chi_{(1,1)} + \chi_{(3,0)}) q^{\frac{9}{2}} \\
&\quad + (\chi_2^J (3\chi_{(0,1)} + 3\chi_{(2,0)}) + \chi_{(0,1)} - 2\chi_{(1,2)} + \chi_{(2,0)} - 4\chi_{(3,1)}) q^5 + \mathcal{O}(q^{\frac{11}{2}}), \\
\mathcal{I}_{SO(6)} &= 1 + \chi_{(2,0)} q^2 - \chi_1^J \chi_{(1,0)} q^{\frac{5}{2}} + (1 - \chi_{(1,1)} + \chi_{(3,0)}) q^3 + \chi_1^J \chi_{(0,1)} q^{\frac{7}{2}} \\
&\quad + (\chi_{(0,2)} + \chi_{(1,0)} - \chi_2^J \chi_{(1,0)} - \chi_{(2,1)} + 2\chi_{(4,0)}) q^4 + \chi_1^J (-\chi_{(1,1)} - \chi_{(3,0)}) q^{\frac{9}{2}} \\
&\quad + (-\chi_{(0,1)} + 2\chi_2^J \chi_{(0,1)} + 2\chi_{(2,0)} - \chi_{(3,1)} + \chi_{(5,0)}) q^5 \\
&\quad + (\chi_1^J (\chi_{(0,2)} + \chi_{(1,0)} + \chi_{(2,1)}) - \chi_3^J \chi_{(1,0)}) q^{\frac{11}{2}} \\
&\quad + (1 - 2\chi_{(1,1)} + \chi_{(3,0)} - \chi_{(4,1)} + 3\chi_{(6,0)} + \chi_2^J (-1 - 2\chi_{(1,1)} - \chi_{(3,0)})) q^6 \\
&\quad + (\chi_1^J (-\chi_{(0,1)} + \chi_{(2,0)} - 2\chi_{(5,0)}) + \chi_3^J (2\chi_{(0,1)} + \chi_{(2,0)})) q^{\frac{13}{2}} \\
&\quad + (-\chi_4^J \chi_{(1,0)} + \chi_2^J (2\chi_{(0,2)} + 2\chi_{(1,0)} + \chi_{(2,1)}) \\
&\quad \quad + \chi_{(1,0)} + \chi_{(4,0)} - 2\chi_{(5,1)} + 2\chi_{(7,0)}) q^7 + \mathcal{O}(q^{\frac{15}{2}}), \tag{4.28}
\end{aligned}$$

$$\begin{aligned}
\mathcal{I}_{SO(3)} &= 1 + \chi_{(2,0)} q^2 - \chi_1^J \chi_{(1,0)} q^{\frac{5}{2}} + (1 - \chi_{(1,1)}) q^3 + \chi_1^J (\chi_{(0,1)} + \chi_{(2,0)}) q^{\frac{7}{2}} \\
&\quad + (-\chi_2^J \chi_{(1,0)} + \chi_{(4,0)}) q^4 + \mathcal{O}(q^{\frac{9}{2}}), \\
\mathcal{I}_{SO(5)} &= 1 + \chi_{(2,0)} q^2 - \chi_1^J \chi_{(1,0)} q^{\frac{5}{2}} + (-\chi_{(1,1)} + 1) q^3 + \chi_1^J (\chi_{(2,0)} + \chi_{(0,1)}) q^{\frac{7}{2}} \\
&\quad + (2\chi_{(4,0)} + \chi_{(0,2)} - \chi_2^J \chi_{(1,0)}) q^4 - \chi_1^J (-2\chi_{(1,1)} - 2\chi_{(3,0)}) q^{\frac{9}{2}} \\
&\quad + (2\chi_2^J \chi_{(0,1)} - \chi_{(0,1)} - \chi_{(1,2)} + \chi_{(2,0)} + \chi_{(5,0)}) q^5 \\
&\quad + (-\chi_3^J \chi_{(1,0)} + \chi_1^J (2\chi_{(0,2)} + \chi_{(1,0)} + 4\chi_{(2,1)} + 2\chi_{(4,0)})) q^{\frac{11}{2}} \\
&\quad + (\chi_2^J (-1 - 4\chi_{(1,1)} - 3\chi_{(3,0)}) - 1 + \chi_{(0,3)} - 3\chi_{(1,1)} + \chi_{(2,2)} + \chi_{(4,1)} \\
&\quad\quad + 2\chi_{(6,0)}) q^6 + \mathcal{O}(q^{\frac{13}{2}}), \\
\mathcal{I}_{SO(7)} &= 1 + \chi_{(2,0)} q^2 - \chi_1^J \chi_{(1,0)} q^{\frac{5}{2}} + (1 - \chi_{(1,1)}) q^3 + \chi_1^J (\chi_{(0,1)} + \chi_{(2,0)}) q^{\frac{7}{2}} \\
&\quad + (-\chi_2^J \chi_{(1,0)} + \chi_{(0,2)} + 2\chi_{(4,0)}) q^4 + \chi_1^J (-2\chi_{(1,1)} - 2\chi_{(3,0)}) q^{\frac{9}{2}} \\
&\quad + (\chi_2^J (2\chi_{(0,1)} + \chi_{(2,0)}) - \chi_{(1,2)} + 2\chi_{(2,0)} - 2\chi_{(3,1)}) q^5 \\
&\quad + (-\chi_3^J \chi_{(1,0)} + \chi_1^J (2\chi_{(0,2)} + \chi_{(1,0)} + 4\chi_{(2,1)} + 2\chi_{(4,0)})) q^{\frac{11}{2}} \\
&\quad + (\chi_2^J (-1 - 4\chi_{(1,1)} - 3\chi_{(3,0)}) + \chi_{(0,3)} - 3\chi_{(1,1)} + 2\chi_{(2,2)} + \chi_{(4,1)} + 3\chi_{(6,0)}) q^6 \\
&\quad + (\chi_3^J (2\chi_{(0,1)} + 2\chi_{(2,0)}) + \chi_1^J (-\chi_{(0,1)} - 5\chi_{(1,2)} - \chi_{(2,0)} - 6\chi_{(3,1)} - 4\chi_{(5,0)})) q^{\frac{13}{2}} \\
&\quad + (\chi_4^J (-\chi_{(1,0)}) + \chi_2^J (5\chi_{(0,2)} + 4\chi_{(1,0)} + 8\chi_{(2,1)} + 4\chi_{(4,0)}) + 3\chi_{(0,2)} + 4\chi_{(1,0)} \\
&\quad\quad - 2\chi_{(1,3)} + 4\chi_{(2,1)} - 3\chi_{(3,2)} + 3\chi_{(4,0)} - 4\chi_{(5,1)}) q^7 + \mathcal{O}(q^{\frac{15}{2}}). \tag{4.29}
\end{aligned}$$

Finally, we calculate the index in the large  $N$  limit. Like the BPS partition function, the large  $N$  index is the same for  $SO(2N)$  and  $SO(2N+1)$  because we cannot distinguish these two theories in  $N \rightarrow \infty$ . The procedure of the calculation process is almost the same as that of the  $U(N)$  theory: the saddle point method. This analysis is given in [19], and the result is

$$\mathcal{I}_{SO(\infty)}^{\text{CFT}} = \text{Pexp}(i_{\text{sp}}^{SO(\infty)}), \quad i_{\text{sp}}^{SO(\infty)} = \frac{1}{2} i_{\text{sp}}^{\text{KK}} + \frac{(1 - i_{\text{sp}}(q, y, u, v))^2}{4(1 - i_{\text{sp}}(q^2, y^2, u^2, v^2))} - \frac{1}{4}, \tag{4.30}$$

where  $i_{\text{sp}}^{\text{KK}}$  is defined in (2.113), and  $i_{\text{sp}}$  is defined in (2.57).

## 4.2 S-fold theories

In this section, we would like to define the S-fold theories and investigate the properties of the S-fold theories.

An S-fold action is defined as the  $\mathbb{Z}_k$  generalization of the orientifold action [18]. First,

the S-fold action acts on the coordinates as

$$(X, Y, Z) \rightarrow (\omega_k^{-1}X, \omega_k Y, \omega_k Z), \quad \omega_k = \exp\left(\frac{2\pi i}{k}\right). \quad (4.31)$$

This is actually the  $\mathbb{Z}_k$  generalization of (4.1). This transformation is realized by

$$\exp\left(\frac{2\pi i}{k}S\right) \in SO(6)_R, \quad S = -R_X + R_Y + R_Z, \quad (4.32)$$

where  $R_X$ ,  $R_Y$ , and  $R_Z$  are the  $SO(6)_R$  Cartan generators defined by (2.1).

To define the S-fold action for massless fields in type IIB string theory, it is convenient to regard the type IIB supergravity with the axio-dilaton field  $\tau$  as the  $SL(2, \mathbb{R})/U(1)$  non-linear sigma model [41, 42]. In this formalism, we introduce an  $SL(2, \mathbb{R})$ -valued scalar field

$$V = \begin{pmatrix} v_2^x & v_2^y \\ v_1^x & v_1^y \end{pmatrix} \in SL(2, \mathbb{R}). \quad (4.33)$$

It is also useful to define complex scalar fields  $v_a$  ( $a = 1, 2$ ) as

$$v_a = v_a^x + iv_a^y \quad (4.34)$$

The scalar field  $V$  is transformed under the global  $SL(2, \mathbb{R})$  symmetry and the local  $U(1) \simeq SO(2)$  symmetry as

$$V \rightarrow gV, \quad g \in SL(2, \mathbb{R}), \quad (4.35)$$

$$V \rightarrow Vh^{-1}, \quad h \in SO(2). \quad (4.36)$$

Although there are unphysical degrees of freedom in the scalar field  $V$  in this formalism, we can remove them by the gauge fixing of the local  $U(1)$  symmetry. The axio-dilaton field is given by the gauge invariant combination

$$\tau = \frac{v_2}{v_1}. \quad (4.37)$$

Let  $\widehat{V}$  be the expectation value of  $V$ . It breaks  $SL(2, \mathbb{R}) \times U(1)$  into  $U(1)_Y$ . This symmetry is determined by the equation

$$\widehat{V} = g\widehat{V}h^{-1}. \quad (4.38)$$

This global  $U(1)_Y$  symmetry plays a significant role in the S-fold action. The fermionic fields in type IIB string theory are transformed non-trivially under  $U(1)_Y$ , while the bosonic fields are invariant. We summarize the charge of each field under  $U(1)_Y$  in Table 4.2.

fields	$Y$
$v_{a=1,2}$	-2
$\lambda_L^M$	-1
$\chi_R$	-3

Table 4.2  $U(1)_Y$  charges of each massless field of type IIB string theory. We only show the fields with non-trivial  $U(1)_Y$  charges.

$k$	$\tau$
2	any
3	$e^{\frac{\pi i}{3}}$
4	$i$
6	$e^{\frac{2\pi i}{3}}$

Table 4.3 The value of  $\tau$  for each S-fold theory. In  $k = 2$ ,  $\tau$  can take any value, and this is consistent to the orientifold theories.

The non-trivial  $U(1)_Y$  charge of the gravitino  $\lambda_L^M$  implies that the supercharges also carry the non-trivial  $U(1)_Y$  charge. Let  $Y$  be the  $U(1)_Y$  generator. The commutation relation between  $Y$  and  $Q^I$ , which generates the  $\mathcal{N} = 4$  supersymmetry on the CFT side, is given by

$$[Y, Q^I] = -Q^I. \quad (4.39)$$

If we take into account the flux quantization for the 3-form fluxes (2.75),  $U(1)_Y$  is broken to its discrete subgroup  $\mathbb{Z}_k$ . Let  $q^a, a = 1, 2$  be the magnetic charges of the  $(p, q)$ -string associated with the 3-form fields:

$$q^1 = \frac{1}{2\pi} \int H_3, \quad q^2 = \frac{1}{2\pi} \int F_3, \quad (4.40)$$

where the  $H_3$  and  $F_3$  are the 3-form fluxes associated with the R-R 2-form fields  $C_2$  and  $B_2$ . Then the quantized charge  $q^C = \hat{v}_a q^a$  form the charge lattice with modulus  $\tau = \hat{v}_2/\hat{v}_1$ . Now the charge lattice must be invariant under  $\mathbb{Z}_k$ .  $k = 2$  is possible for the generic value of  $\tau$  while  $k = 3, 4, 6$  are possible only for

$$\tau = \exp\left(i\pi \frac{k-2}{k}\right). \quad (4.41)$$

We classify the value of  $\tau$  in Table 4.3 and show an example of the invariant charge lattice for  $k = 3$  in Fig. 4.1.

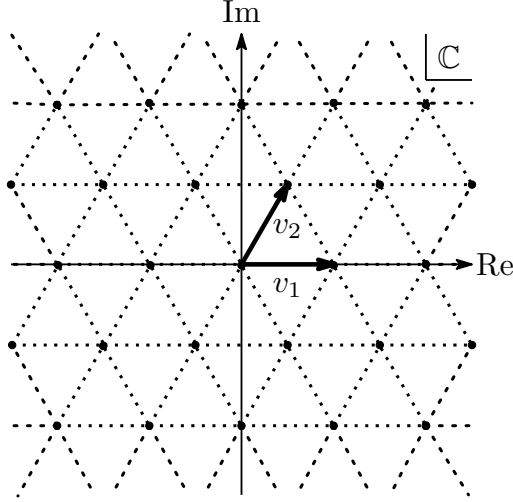

Fig. 4.1 An example of the invariant string charge lattice defined by  $q^C = \widehat{v}_a q^a$  for  $k = 3$ . To make the lattice invariant under  $\mathbb{Z}_3$ , the modulus  $\tau = \widehat{v}_2/\widehat{v}_1$  must be  $e^{\frac{\pi i}{3}}$  fixed.

Now we define the  $\mathbb{Z}_k$  S-fold action  $\mathcal{R}$  for  $k = 3, 4, 6$  as [18]

$$\mathcal{R} = \exp \left[ \frac{2\pi i}{k} \left( S - \frac{Y}{2} \right) \right], \quad (4.42)$$

where  $S$  is defined in (4.32).

### 4.2.1 AdS/CFT correspondence in the S-fold background

Let us consider a stack of  $N$  parallel D3-branes in the S-fold background defined by  $\mathbb{R}^{1,3} \times \mathbb{C}^3/\mathcal{R}$ , where  $\mathcal{R}$  is the S-fold action (4.42). We define a 4d rank  $N$   $\mathbb{Z}_k$  S-fold theory as the worldvolume theory on the D3-branes [18]. If we take the near horizon limit, the geometry becomes  $AdS_5 \times S^5/\mathbb{Z}_k$  due to the S-fold action (4.31).

As in the orientifold case, there are several variants of S-fold theories due to the discrete torsion. In the S-fold background, the discrete torsion associated with the 3-form fluxes is given by [19, 20]

$$H^3(S^5/\mathbb{Z}_k, \widetilde{\mathbb{Z} \oplus \mathbb{Z}}) = \begin{cases} \mathbb{Z}_3 & \text{for } k = 3, \\ \mathbb{Z}_2 & \text{for } k = 4, \\ \mathbb{Z}_1 & \text{for } k = 6. \end{cases} \quad (4.43)$$

For  $k = 3$ , the torsion group is  $\mathbb{Z}_3$ , so we have three variants about the  $\mathbb{Z}_3$  S-fold. Theories corresponding to non-trivial elements of  $\mathbb{Z}_3$  are related by the S-duality, as in the orientifold case. For  $k = 4$ , there are two variants. However, for  $k = 6$ , there is only one variant. We summarize this knowledge in Table 4.4.

Then an S-fold theory is specified by the value of  $k$ ,  $N$ , and discrete torsion. We denote

$k$	discrete torsion	# of variants
2	$\mathbb{Z}_2 \oplus \mathbb{Z}_2$	4
3	$\mathbb{Z}_3$	3
4	$\mathbb{Z}_2$	2
6	$\mathbb{Z}_1$	1

Table 4.4 A table for the discrete torsion for S-fold theories. As in the orientifold case, the two variants with the non-trivial torsion in the  $\mathbb{Z}_3$  S-fold are related by the S-duality.

the theory by  $S(N, k, p)$ , where  $p = 0, 1$ .  $p = 0$  corresponds to the trivial torsion, and  $p = 1$  corresponds to a non-trivial torsion. The AdS/CFT correspondence regarding S-fold theories is [19, 20]

$$4d \mathbb{Z}_k \text{ S-fold theory} \iff \text{Type IIB string theory on } AdS_5 \times S^5/\mathbb{Z}_k. \quad (4.44)$$

for  $k = 3, 4, 6$ .

Like the orientifold case, there are also Pfaffian-like operators in the S-fold theories with the trivial torsion, called the generalized Pfaffian operators [20]. Corresponding objects are the wrapped D3-branes on a non-trivial three-cycle in  $S^5/\mathbb{Z}_k$ , and they are classified by the third homology group

$$H_3(S^5/\mathbb{Z}_k, \mathbb{Z}) = \mathbb{Z}_k. \quad (4.45)$$

Corresponding charge to  $\mathbb{Z}_k$  is called the winding number of wrapped D3-branes. These wrapped D3-branes give the finite  $N$  corrections to the index [19].

### 4.2.2 Properties of S-fold theories

In this subsection, we review some remarkable properties of S-fold theories summarized as follows:

- S-fold theories have  $\mathcal{N} = 3$  supersymmetry [18].
- S-fold theories have no marginal deformation [18, 38]<sup>\*3</sup>. Then, the Lagrangian of S-fold theories is not known.
- It was conjectured that the rank one and two S-fold theories are equivalent to  $\mathcal{N} = 4$  SYMs with rank one and two gauge groups [20] (Aharony-Tachikawa conjecture).

Let us see these properties in more detail below.

<sup>\*3</sup> Precisely speaking, marginal deformations that do not respect  $\mathcal{N} = 3$  supersymmetry are not prohibited. In fact, the marginal deformation that breaks  $\mathcal{N} = 3$  to  $\mathcal{N} = 1$  was discussed in [21].

	$R_X$	$R_Y$	$R_Z$	$S$	$Y$	$S - Y/2$
$\overline{Q}_1$	$\frac{1}{2}$	$\frac{1}{2}$	$\frac{1}{2}$	$\frac{1}{2}$	1	0
$\overline{Q}_2$	$\frac{1}{2}$	$-\frac{1}{2}$	$-\frac{1}{2}$	$-\frac{3}{2}$	1	-2
$\overline{Q}_3$	$-\frac{1}{2}$	$\frac{1}{2}$	$-\frac{1}{2}$	$\frac{1}{2}$	1	0
$\overline{Q}_4$	$-\frac{1}{2}$	$-\frac{1}{2}$	$\frac{1}{2}$	$\frac{1}{2}$	1	0

Table 4.5  $S$  and  $Y$  charges of supercharges of an  $\mathcal{N} = 4$  supersymmetry, where  $S = -R_X + R_Y + R_Z$ . If we impose the  $\mathbb{Z}_k$  identification generated by (4.42) for supercharges,  $\overline{Q}_2$  and  $Q^2$  are projected out, and an  $\mathcal{N} = 3$  supersymmetry is realized. The removed charge is just a convention, and if we use another convention for  $S$ , corresponding another supercharge would be removed.

### $\mathcal{N} = 3$ supersymmetry

The S-fold theories are obtained by imposing the invariance under the S-fold action (4.42) on the worldvolume theory on  $N$  D3-branes, namely  $\mathcal{N} = 4$  SYM. The behavior of the  $\mathcal{N} = 4$  supercharges  $\overline{Q}_I$  are shown in Table 4.5. From this table, if we impose the S-fold invariance on supercharges, we see that  $\overline{Q}_2$  is projected out. Then the  $\mathcal{N} = 3$  supersymmetry is realized in S-fold theories.

### No marginal deformation

It is known that genuine  $\mathcal{N} = 3$  theories have no marginal deformation [38]. Thus the S-fold theories also have no marginal deformation, and it was shown in [18]. Then, the S-fold theories are not connected to a free theory, and the Lagrangian is not known. This fact is consistent with the fixing of the complex coupling constant  $\tau$  defined in (2.15). Note that marginal deformations that do not respect  $\mathcal{N} = 3$  supersymmetry are allowed.

### Aharony-Tachikawa conjecture

It is known that if a genuine  $\mathcal{N} = 3$  theory has a Coulomb branch operator with dimension one or two, the  $\mathcal{N} = 3$  supersymmetry is non-trivially enhanced to the  $\mathcal{N} = 4$  supersymmetry [38]. This is also the case for some of the S-fold theories. To see this, let us investigate the Coulomb branch operators of S-fold theories following [20].

As we saw in subsection 2.1.2, the Coulomb branch operators parametrize the Coulomb branch of a theory. In  $\mathcal{N} = 4$   $U(N)$  SYM, the Coulomb branch is  $\mathbb{C}/\mathcal{W}_{U(N)}$ , where  $\mathcal{W}_{U(N)} = S_N$  is the Weyl group of  $U(N)$ . From the viewpoint of the  $N$  D3-branes system, the Weyl transformation is regarded as the exchanging of  $N$  D3-branes located at  $z_i \in \mathbb{C} \subset \mathbb{C}^3$  ( $i = 1, \dots, N$ ). In the S-fold case,  $\mathbb{C}^3$  is replaced by  $\mathbb{C}^3/\mathbb{Z}_k$ , and the Weyl

transformation is given by [20]

$$(z_i, z_j) \leftrightarrow (z_j, z_i), \quad (4.46a)$$

$$(z_i, z_j) \rightarrow (\omega_k z_i, \omega_k^{-1} z_j), \quad (4.46b)$$

$$z_i \rightarrow \omega_k^r z_i, \quad (4.46c)$$

where  $r$  is a divisor of  $k$ .  $r = k$  corresponds to the trivial discrete torsion and  $r \neq 0$  corresponds to a non-trivial torsion. Now the first transformation is  $S_N$  generated by the symmetric polynomials  $\sum_{\sigma \in S_N} z_{\sigma(i)}$ . However, in order to make polynomials invariant under (4.46b) and (4.46c) as well, we need  $z_i \rightarrow z_i^k$ . We also find that  $(z_1 z_2 \cdots z_N)^l$  is invariant, where  $l = k/r$ . Thus the dimension of Coulomb branch operators is [20]

$$k, 2k, 3k, \dots, (N-1)k; Nl. \quad (4.47)$$

Let us consider the non-trivial supersymmetry enhancement of S-fold theories. From the list of the dimension of the Coulomb branch operators (4.47), we find that the supersymmetry enhancement always occurs for  $k = 2$ , and this is consistent with the orientifold. We also find that for  $N = 1, 2$  with  $k = 3, 4, 6$  and  $l = 1$ , or equivalently  $r = k$  there exists the Coulomb branch operators with dimension two. All these S-fold theories have the trivial discrete torsion. Thus, we expect that  $(N, k, l) = (1, k, 1), (2, k, 1)$  cases are equivalent to certain  $\mathcal{N} = 4$  theories<sup>\*4</sup>. In terms of the notation  $S(N, k, p)$  introduced in subsection 4.2.1,  $(1, k, 1), (2, k, 1)$  cases are  $S(1, k, 0)$  and  $S(2, k, 0)$ . Since it is believed that any  $\mathcal{N} = 4$  theory is an  $\mathcal{N} = 4$  SYM, these S-fold theories may be equivalent to certain  $\mathcal{N} = 4$  SYM.

For  $N = 1$ , namely the rank one case, the only possible gauge group is  $U(1)$ . So it is expected that a rank one S-fold theories with trivial torsion are equivalent to the  $\mathcal{N} = 4$  Maxwell theory. In order to determine the gauge group of rank two case, let us focus on the dimension of all independent single-particle Coulomb branch operators:

$$E_{\text{CBO}} = \begin{cases} 2, 3 & \text{for } k = 3, \\ 2, 4 & \text{for } k = 4, \\ 2, 6 & \text{for } k = 6. \end{cases} \quad (4.48)$$

These spectra agree with those of  $SU(3)$ ,  $SO(5)$ , and  $G_2$ , respectively. Therefore, it is expected that rank two S-fold theories with the trivial torsion are equivalent to  $\mathcal{N} = 4$  SYMs with the gauge group  $SU(3)$ ,  $SO(5)$ , and  $G_2$  (shown in Table 4.6). This was conjectured by Aharony and Tachikawa in [20], so we call this conjecture Aharony-Tachikawa (AT) conjecture. We will confirm AT conjecture by using the BPS partition function and the superconformal index.

---

<sup>\*4</sup> We can always construct the Coulomb branch operators with dimension two from those with dimension one.

theory	$G$	$E_{\text{CBO}}$
$S(1, k, 0)$	$U(1)$	1
$S(2, 3, 0)$	$SU(3)$	2,3
$S(2, 4, 0)$	$SO(5)$	2,4
$S(2, 6, 0)$	$G_2$	2,6

Table 4.6 A list of the gauge group and corresponding S-fold theories. For rank one, all S-fold theories with trivial torsion are enhanced to the  $\mathcal{N} = 4$  Maxwell theory. For the rank two case, we can obtain the corresponding gauge group by comparing the spectrum of the Coulomb branch operators.

### 4.3 BPS partition function of S-fold theories

In this section, we find the BPS partition function of S-fold theories by generalizing the results of  $\mathcal{N} = 4$   $SO(N)$  SYM. This analysis is not on the AdS side but the CFT side. This is possible even though the Lagrangian is unknown because the BPS partition function is constructed as the invariant polynomial under the Weyl transformation. However, this is not the case for the superconformal index. In general, we have no idea to find the superconformal index on the CFT side. We have to use the AdS/CFT correspondence to obtain the index of S-fold theories.

Since the BPS partition function counts the primary scalars of the theory, it is enough to consider the  $\mathbb{Z}_k$  orbifold (4.31). In  $\mathcal{N} = 3$  we no longer use the term  $\frac{1}{2}, \frac{1}{4}, \frac{1}{8}$ -BPS because the number of supercharges were changed. Instead of these terms, we simply call the BPS partition function with three variables  $(x, y, z)$  as the BPS partition function, and the BPS partition function with the specialization of  $z = 0$  and  $x = y = 0$  called the Higgs branch Hilbert series and the Coulomb branch Hilbert series.

Let us generalize the Weyl transformation (4.46) for three coordinates  $(x_i, y_i, z_i) \in \mathbb{C}^3/\mathbb{Z}_k$ . Each of variables specifies the location of  $N$  D3-branes in the S-fold backgrounds. The generalization is simply given by

$$\{(x_i, y_i, z_i), (x_j, y_j, z_j)\} \leftrightarrow \{(x_j, y_j, z_j), (x_i, y_i, z_i)\}, \quad (4.49a)$$

$$\{(x_i, y_i, z_i), (x_j, y_j, z_j)\} \rightarrow \{(\omega_k^{-1}x_i, \omega_k y_i, \omega_k z_i), (\omega_k x_j, \omega_k^{-1}y_j, \omega_k^{-1}z_j)\}, \quad (4.49b)$$

$$(x_i, y_i, z_i) \rightarrow (\omega_k^{-p}x_i, \omega_k^p y_i, \omega_k^p z_i), \quad (4.49c)$$

where  $p$  is a divisor of  $k$  again.

Let us remind that the oscillator formalism we have used in subsection 2.1.3, in which we interpret  $(x_i, y_i, z_i)$  as coordinates of each oscillator. The first transformation is simply  $S_N$ , so this indicates that we can treat each oscillator as a boson. The second condition

requires that all single wave functions should satisfy a common boundary condition

$$\Psi(\omega_k^{-1}x, \omega_k y, \omega_k z) = \omega_k^m \Psi(x, y, z), \quad (4.50)$$

where  $m \in \{1, 2, \dots, k-1\}$ . It specifies to which element of  $\mathbb{Z}_k$  corresponds. Thus the invariant single-particle BPS partition function can be calculated as

$$\begin{aligned} I_m^{\mathbb{Z}_k}(x, y, z) &= \sum_{-n_x+n_y+n_z=m \bmod k} x^{n_x} y^{n_y} z^{n_z} \\ &= \frac{1}{k} \sum_{l=0}^{k-1} \frac{\omega_k^{-ml}}{(1 - \omega_k^{-l}x)(1 - \omega_k^l y)(1 - \omega_k^l z)}, \end{aligned} \quad (4.51)$$

where  $n_x, n_y, n_z \geq 0$ . Note that  $I_m^{\mathbb{Z}_k}(x, y, z)$  satisfies

$$I_m^{\mathbb{Z}_k}(\omega_k^{-1}x, \omega_k y, \omega_k z) = \omega_k^m I_m^{\mathbb{Z}_k}(x, y, z). \quad (4.52)$$

To obtain the grand partition function, we finally have to take the third condition (4.49c) into account. Actually, this condition is related to the discrete torsion. If  $p = k$  corresponding to the trivial torsion, the condition (4.49c) does not make sense. It requires  $pm = 0 \bmod k$ . Thus we have

$$\Xi_{S(*,k,p)}(x, y, z; t) = \sum_{pm=0} \text{Pexp}(I_m^{\mathbb{Z}_k} t), \quad (4.53)$$

where we adopt  $p = 0$  instead of  $p = k$  for the trivial torsion.  $S(N, k, p)$  is a label of a rank  $N$   $\mathbb{Z}_k$  S-fold theory with  $p$ , which corresponds to the discrete torsion. This expression indeed reproduces the orientifold case (4.22). We can interpret the non-zero  $m$  sectors as the contributions from the generalized Pfaffians.

Let us find the BPS partition function of S-fold theories in the large  $N$  limit. By using the formula (2.99), we immediately obtain

$$Z_{S(\infty, k, p)}(x, y, z) = \text{Pexp}(I_0^{\mathbb{Z}_k}(x, y, z) - 1). \quad (4.54)$$

Let us find the BPS partition function of S-fold theories in the large  $N$  limit. By using the formula (2.99), we immediately obtain (4.54). The non-zero  $m$  sectors decouple because the generalized Pfaffians have a conformal dimension larger than or equal to  $N$ . On the AdS side, this means that the corresponding wrapped D3-branes becomes too heavy to participate in the physics.

### Supersymmetry enhancement

Let us check the supersymmetry enhancement in terms of the BPS partition function. To see this, we pick up  $N = 1, 2$  BPS partition functions from the grand partition function.

For  $N = 1$ , we have

$$Z_{S(1,k,0)}(x, y, z) = \sum_{m=0}^{k-1} I_m^{\mathbb{Z}^k} = I(x, y, z) = Z_{U(1)}(x, y, z). \quad (4.55)$$

Thus this is consistent with the supersymmetry enhancement of rank one S-fold theories.

For  $N = 2$ , we must obtain the BPS partition functions of  $\mathcal{N} = 4$  SYM with  $SU(3), SO(5), G_2$  gauge groups. The results obtained from the grand partition function (4.53) are

$$Z_{S(2,3,0)} = \frac{1}{6(1-x)^2(1-y)^2(1-z)^2} + \frac{1}{2(1-x^2)(1-y^2)(1-z^2)} + \frac{1}{3(1+x+x^2)(1+y+y^2)(1+z+z^2)}, \quad (4.56)$$

$$Z_{S(2,4,0)} = \frac{1}{8(1-x)^2(1-y)^2(1-z)^2} + \frac{1}{8(1+x)^2(1+y)^2(1+z)^2} + \frac{1}{2(1-x^2)(1-y^2)(1-z^2)} + \frac{1}{4(1+x^2)(1+y^2)(1+z^2)}, \quad (4.57)$$

$$Z_{S(2,6,0)} = \frac{1}{12(1-x)^2(1-y)^2(1-z)^2} + \frac{1}{12(1+x)^2(1+y)^1(1+z)^2} + \frac{1}{2(1-x^2)(1-y^2)(1-z^2)} + \frac{1}{6(1-x+x^2)(1-y+y^2)(1-z+z^2)} + \frac{1}{6(1+x+x^2)(1+y+y^2)(1+z+z^2)}, \quad (4.58)$$

and they are indeed equal to  $Z_{SU(3)}, Z_{SO(5)}, Z_{G_2}$ , respectively. The  $Z_{G_2}$  can be calculated by the Mölien series. Therefore, we checked the supersymmetry enhancement in terms of the BPS partition function.

## 4.4 Large $N$ limit on the AdS side

Before going to the calculation of the finite  $N$  corrections to the BPS partition function and the superconformal index of S-fold theories, we need to find the expression of the large  $N$  limit as a zeroth correction. In the case of the BPS partition function, we can compare with the results calculated in the last section. On the other hand, the superconformal index is non-calculable on the CFT side, the result on the AdS side is the unique expression we can find. The analysis of the index on the large  $N$  limit was already done by Imamura and Yokoyama [19], then we review it.

### 4.4.1 BPS partition function

Now let us consider the BPS partition function of S-fold theories in the large  $N$  limit on the AdS side. As in the case of  $U(N)$ , the contributions in the large  $N$  limit come from the KK modes on  $S^5/\mathbb{Z}_k$  in  $\mathbb{Z}_k$  S-folds. Since the BPS partition functions count only the primary scalars and they form an  $(n, 0, 0)$  representation of  $SO(6)_R$  which is real, it is enough to consider the effect of  $\mathbb{Z}_k$  orbifold (4.31).

To realize the  $\mathbb{Z}_k$  orbifold for the BPS partition function, we impose the  $\mathbb{Z}_k$  invariance of the single-particle BPS partition function of KK modes on  $S^5$ :  $I(x, y, z) - 1$ . For  $x, y, z$  fugacities, the  $\mathbb{Z}_k$  orbifold is defined as

$$(x, y, z) \rightarrow (\omega_k^{-1}x, \omega_k y, \omega_k z). \quad (4.59)$$

The single-particle BPS partition function of KK modes should be invariant under  $\mathbb{Z}_k$  orbifold. Thus we have

$$\mathcal{P}_k I(x, y, z) - 1 = \frac{1}{k} \sum_{m=0}^{k-1} I(\omega_k^{-1}x, \omega_k y, \omega_k z) - 1 = I_0^{\mathbb{Z}_k}(x, y, z) - 1, \quad (4.60)$$

where the orbifold projection  $\mathcal{P}_k$  is defined by

$$\mathcal{P}_k f(x, y, z) = \frac{1}{k} \sum_{m=0}^{k-1} f(\omega_k^{-1}x, \omega_k y, \omega_k z). \quad (4.61)$$

Its plethystic exponential agrees with (4.54). Therefore we proved that the BPS partition function of S-fold theory in the large  $N$  limit is the same on both sides.

### 4.4.2 Superconformal index

Now let us consider the superconformal index of S-fold theories in the large  $N$  limit on the AdS side. For calculations of the index, we adopt the same technique as the BPS partition function calculated in the last subsection. Namely, we perform the S-fold projection for the single-particle index of KK modes on  $S^5$  given in (2.113).

However, there is a different point from the last subsection: we count not only primary scalars but also other fields constructed by the supersymmetric completion in the index. The problem is that other fields are in general charged under  $\mathbb{Z}_k \subset U(1)_Y$  because supercharges have a non-trivial charge under  $U(1)_Y$ . Thus we have to use  $\mathcal{R}$  given in (4.42) when the projection. To do it, we add a new fugacity  $\eta$  regarding  $\mathcal{R}$  to the single-particle index and define the “refined” single-particle index

$$\tilde{i}_{\text{sp}}(\eta) = \text{tr}_{\text{sp}}[(-1)^F \bar{x}^{\bar{\Delta}} q^{E+j_R} y^{2j_L} u^{R_X-R_Y} v^{R_Y-R_Z} \eta^{S-Y/2}], \quad (4.62)$$

where  $S = -R_X + R_Y + R_Z$ . Before the S-folding, the supersymmetry is  $\mathcal{N} = 4$ , so we may expect that the refined index would respect the  $SU(3)_R \subset SU(4)_R$  symmetry, which is generated by  $R_X - R_Y$  and  $R_Y - R_Z$ . However,  $S$  does not commute with this  $SU(3)_R$ , and the refined index is not represented by  $SU(3)_R$  characters. To avoid this troublesome calculation, we split  $S$  into  $SU(3)_R$  Cartan parts and an  $SU(3)_R$  invariant part as follows:

$$S = -R_X + R_Y + R_Z = -\frac{4}{3}(R_X - R_Y) - \frac{2}{3}(R_Y - R_Z) + \frac{1}{3}(R_X + R_Y + R_Z), \quad (4.63)$$

where  $R_X + R_Y + R_Z$  is invariant under  $SU(3)_R$ . Then we can write the refined index (4.62) in the form respecting  $SU(3)_R$ :

$$\tilde{i}_{\text{sp}}(\eta) = \text{tr}_{\text{sp}} \left[ (-1)^{F\bar{x}\bar{\Delta}} q^{E+j_R} y^{2j_L} \left( u\eta^{-\frac{4}{3}} \right)^{R_X - R_Y} \left( v\eta^{-\frac{2}{3}} \right)^{R_Y - R_Z} \eta^T \right], \quad (4.64a)$$

$$T \equiv \frac{1}{3}(R_X + R_Y + R_Z) + \frac{Y}{2}. \quad (4.64b)$$

So we use the variables  $u\eta^{-\frac{4}{3}}$  and  $v\eta^{-\frac{2}{3}}$  instead of  $u$  and  $v$  for  $SU(3)_R$  characters.

Now we can calculate the refined single-particle index of KK modes from the Table 2.10 and the  $T$  charges. We list  $T$  charges in Table 4.7 as well as  $Y$  charges, corresponding to KK modes listed in Table 2.10. The result is

$$\begin{aligned} \tilde{i}_{\text{sp}}^{\text{KK}}(\eta) &= \frac{1}{(1 - \frac{u}{u}q)(1 - \frac{v\eta}{u}q)(1 - \frac{\eta}{v}q)(1 - q^{\frac{3}{2}}y)(1 - q^{\frac{3}{2}}y^{-1})} \\ &\times \left[ \left( \frac{u}{\eta} + \frac{v\eta}{u} + \frac{\eta}{v} \right) q - \eta(y + y^{-1})q^{\frac{3}{2}} - (1 + \eta) \left( \frac{v}{\eta} + \frac{u}{v\eta} + \frac{\eta}{u} \right) q^2 \right. \\ &\quad + (\eta^{-1} + 1 + 2\eta + \eta^2)q^3 + (y + y^{-1}) \left( v + \frac{u}{v} + \frac{\eta^2}{u} \right) q^{\frac{7}{2}} \\ &\quad \left. - \left( u + \frac{v\eta^2}{u} + \frac{\eta^2}{v} \right) q^4 - (1 + \eta)(y + y^{-1})q^{\frac{9}{2}} + \eta q^6 \right]. \end{aligned} \quad (4.65)$$

Then the single-particle index of KK modes in a  $\mathbb{Z}_k$  S-fold theory labeled by  $S(\infty, k, p)$  is obtained as

$$\tilde{i}_{S(\infty, k, p)}^{\text{KK}} = \mathcal{P}_k \tilde{i}_{\text{sp}}^{\text{KK}}, \quad (4.66)$$

where  $\mathcal{P}_k$  is a projection operator defined as

$$\mathcal{P}_k f(\eta) = \frac{1}{k} \sum_{l=0}^{k-1} f(\eta = \omega_k^l). \quad (4.67)$$

$[j_L, j_R]_E^{(R_X, R_Y, R_Z)}$	$Y$	$T$
$[0, 0]_n^{(n, 0, 0)}$	0	$\frac{n}{3}$
$[\frac{1}{2}, 0]_{n+\frac{1}{2}}^{(n-\frac{1}{2}, \frac{1}{2}, \frac{1}{2})}$	-1	$\frac{n+2}{3}$
$[0, \frac{1}{2}]_{n+\frac{1}{2}}^{(n-\frac{1}{2}, \frac{1}{2}, -\frac{1}{2})}$	1	$\frac{n-2}{3}$
$[0, 1]_{n+1}^{(n-1, 0, 0)}$	2	$\frac{n-4}{3}$
$[0, 0]_{n+1}^{(n-1, 1, 1)}$	-2	$\frac{n+4}{3}$
$[\frac{1}{2}, \frac{1}{2}]_{n+1}^{(n-1, 1, 0)}$	0	$\frac{n}{3}$
$[\frac{1}{2}, 1]_{n+\frac{3}{2}}^{(n-\frac{3}{2}, \frac{1}{2}, \frac{1}{2})}$	1	$\frac{n-2}{3}$
$[0, \frac{1}{2}]_{n+\frac{3}{2}}^{(n-\frac{3}{2}, \frac{3}{2}, \frac{1}{2})}$	-1	$\frac{n+2}{3}$
$[0, 1]_{n+2}^{(n-2, 1, 1)}$	0	$\frac{n}{3}$

Table 4.7 A table for  $T$  charges and  $Y$  charges for KK modes listed in Table 2.10.  $T$  commutes with  $SU(3)_R$  symmetry, and we use the variables  $u\eta^{-\frac{4}{3}}$  and  $v\eta^{-\frac{2}{3}}$  for  $SU(3)_R$  characters.

The multi-particle index is now

$$\mathcal{I}_{S(\infty, k, p)}^{\text{KK}} = \text{Pexp}(i_{S(\infty, k, p)}^{\text{KK}}). \quad (4.68)$$

Note that the difference of the discrete torsion is absent in the large  $N$  limit, so the result is the same for all possible  $p$ .

We give some comments for each  $k = 2, 3, 4, 6$  following.

#### $k = 2$ orientifold

If we take  $k = 2$ , this is the orientifold case. Then we can compare the KK index with the index on the CFT side in the large  $N$  limit. Actually, we can show that

$$\mathcal{I}_{S(\infty, k=2, p)}^{\text{AdS}} = \mathcal{I}_{SO(\infty)}^{\text{CFT}}, \quad (4.69)$$

where the right hand side is given by (4.30).

#### $k = 3, 4, 6$ S-fold

In this case, the index has a different behavior from the index of  $\mathcal{N} = 4$  theories. In  $\mathcal{N} = 4$  theories, there is the  $SU(4)_R$  symmetry, and the index respects  $SU(3)_R$  due to the choice of the supercharge which is used to define the index. However, now, there is only an  $\mathcal{N} = 3$  supersymmetry. Then the index respects  $U(2)_R \subset U(3)_R$  and the index is represented by the  $U(2)_R$  character  $\bar{\chi}_n(u^{-1}v, v^{-1})$  defined by (A.31). Indeed, the KK

indices for  $k = 3, 4, 6$  up to  $q^{\frac{13}{2}}$  become

$$\begin{aligned}
\mathcal{I}_{S(\infty,3,p)}^{\text{KK}} &= 1 + u\bar{\chi}_1 q^2 - u\chi_1^J q^{\frac{5}{2}} + (-1 + u^3 - u\bar{\chi}_2 + \bar{\chi}_3)q^3 + \chi_1^J(2u\bar{\chi}_1 - \bar{\chi}_2)q^{\frac{7}{2}} \\
&+ (-u\chi_2^J - u + 2\bar{\chi}_1 - u^3\bar{\chi}_1 - \frac{1}{u}\bar{\chi}_2 + 2u^2\bar{\chi}_2)q^4 \\
&+ \chi_1^J(-2 + u^3 + \frac{1}{u}\bar{\chi}_1 - 2u^2\bar{\chi}_1 - u\bar{\chi}_2 + \bar{\chi}_3)q^{\frac{9}{2}} \\
&+ (\chi_2^J(2u\bar{\chi}_1 - \bar{\chi}_2) - \frac{1}{u} + 3u^2 - 2u\bar{\chi}_1 + 2u^4\bar{\chi}_1 - 2u^2\bar{\chi}_3 + 2u\bar{\chi}_4)q^5 \\
&+ (-u\chi_3^J + \chi_1^J(3u - 2u^4 + \bar{\chi}_1 - u^3\bar{\chi}_1 - \frac{1}{u}\bar{\chi}_2 + 5u^2\bar{\chi}_2 - 3u\bar{\chi}_3))q^{\frac{11}{2}} \\
&+ (\chi_2^J(-2 + u^3 + \frac{1}{u}\bar{\chi}_1 - 4u^2\bar{\chi}_1 + \bar{\chi}_3) + 1 - 3u^3 + 2u^6 - \frac{1}{u}\bar{\chi}_1 - 4u^2\bar{\chi}_1 \\
&\quad + \frac{1}{u^2}\bar{\chi}_2 + 7u\bar{\chi}_2 - 3u^4\bar{\chi}_2 - 4\bar{\chi}_3 + 4u^3\bar{\chi}_3 - 2u\bar{\chi}_5 + 2\bar{\chi}_6)q^6 \\
&+ \mathcal{O}(q^{\frac{13}{2}}), \tag{4.70}
\end{aligned}$$

$$\begin{aligned}
\mathcal{I}_{S(\infty,4,p)}^{\text{KK}} &= 1 + u\bar{\chi}_1 q^2 - u\chi_1^J q^{\frac{5}{2}} + (-1 - u\bar{\chi}_2)q^3 + 2u\chi_1^J \bar{\chi}_1 q^{\frac{7}{2}} \\
&+ (-u + u^4 - u\chi_2^J + \bar{\chi}_1 + 2u^2\bar{\chi}_2 + \bar{\chi}_4)q^4 \\
&+ \chi_1^J(-2 - 2u^2\bar{\chi}_1 - u\bar{\chi}_2 - \bar{\chi}_3)q^{\frac{9}{2}} \\
&+ (2u\chi_2^J \bar{\chi}_1 + 2u^2 - 2u\bar{\chi}_1 - u^4\bar{\chi}_1 + \bar{\chi}_2 - \frac{1}{u}\bar{\chi}_3 - 2u^2\bar{\chi}_3)q^5 \\
&+ (-u\chi_3^J + \chi_1^J(3u + u^4 + \bar{\chi}_1 + \frac{1}{u}\bar{\chi}_2 + 5u^2\bar{\chi}_2 + \bar{\chi}_4))q^{\frac{11}{2}} \\
&+ (\chi_2^J(-2 - 4u^2\bar{\chi}_1 - u\bar{\chi}_2 - \bar{\chi}_3) + u^3 - \frac{1}{u}\bar{\chi}_1 - 4u^2\bar{\chi}_1 + 2u^5\bar{\chi}_1 \\
&\quad + 4u\bar{\chi}_2 + 3u^2\bar{\chi}_3 + 2u\bar{\chi}_5)q^6 + \mathcal{O}(q^{\frac{13}{2}}), \tag{4.71}
\end{aligned}$$

$$\begin{aligned}
\mathcal{I}_{S(\infty,6,p)}^{\text{KK}} &= 1 + u\bar{\chi}_1 q^2 - u\chi_1^J q^{\frac{5}{2}} + (-1 - u\bar{\chi}_2)q^3 + 2u\chi_1^J \bar{\chi}_1 q^{\frac{7}{2}} \\
&+ (-u - \chi_2^J + \bar{\chi}_1 + 2u^2\bar{\chi}_2)q^4 + \chi_1^J(-2 - 2u^2\bar{\chi}_1 - u\bar{\chi}_2)q^{\frac{9}{2}} \\
&+ (2u^2 - 2u\bar{\chi}_1 + 2u\chi_2^J \bar{\chi}_1 - 2u^2\bar{\chi}_3)q^5 \\
&+ (-u\chi_3^J + \chi_1^J(3u + \bar{\chi}_1 + 5u^2\bar{\chi}_2))q^{\frac{11}{2}} \\
&+ (\chi_2^J(-2 - 4u^2\bar{\chi}_1 - u\bar{\chi}_2) + u^6 - 4u^2\bar{\chi}_1 + 4u\bar{\chi}_2 + 3u^2\bar{\chi}_3 + \bar{\chi}_6)q^6 \\
&+ \mathcal{O}(q^{\frac{13}{2}}). \tag{4.72}
\end{aligned}$$

The fact that the index is represented by the  $U(2)_R$  character indicates that the corresponding theory has  $\mathcal{N} = 3$  supersymmetry. Namely, we can read off the supersymmetry

of the theory from the characters of the  $R$ -symmetry.

## 4.5 Finite $N$ corrections

Let us go to the topic of the finite  $N$  corrections to the BPS partition function and superconformal index of S-fold theories. First, we consider the finite  $N$  corrections to the BPS partition function. After that, we move on to the discussion of the superconformal index.

### 4.5.1 BPS partition function

We consider the finite  $N$  corrections to the BPS partition functions of S-fold theories by considering the single wrapped D3-branes on  $S^3/\mathbb{Z}_k \subset S^5/\mathbb{Z}_k$ . Fortunately, we know the BPS partition functions on the CFT side exactly, and we can compare the finite  $N$  corrections with the CFT results. Note that wrapped D3-branes are only present when the discrete torsion is trivial:  $p = 0$ , so we only consider the trivial torsion case here. The discussions are based on the author's and his collaborators' paper [22].

In the last chapter, we have already done the analysis of finite  $N$  corrections for the  $\mathcal{N} = 4$   $U(N)$  SYM, in which a generic configuration of the single wrapped D3-branes is given by

$$f(X, Y, Z) = aX + bY + cZ = 0. \quad (4.73)$$

Then the complex coefficients  $(a, b, c)$  form  $\mathbb{C}P^2$  as a phase space of single-wrapped D3-branes. Actually, the following analysis is similar to  $\mathcal{N} = 4$   $U(N)$  SYM case.

Now, we have an additional constraint for the holomorphic surface  $f(X, Y, Z) = 0$  in the S-fold background. Since the overall factor does not affect the shape of the holomorphic surface, a  $\mathbb{Z}_k$  S-fold identification gives a constraint

$$f(\omega_k^{-1}X, \omega_k Y, \omega_k Z) = \omega_k^m f(X, Y, Z), \quad (4.74)$$

where an integer  $m$  is the winding number of wrapped D3-branes. This is classified by  $H_3(S^5/\mathbb{Z}_k, \mathbb{Z}) = \mathbb{Z}_k$ , so  $m$  is an integer modulo  $k$ .

In fact, the constraint (4.74) restricts the possible form of the holomorphic function, that is, the possible shape of wrapped D3-branes, depending on the value of  $k$ . In what follows, we consider  $k = 2$  orientifold and  $k = 3, 4, 6$  S-folds separately.

#### $k = 2$ orientifold

In this case, the most general form of the single-wrapping holomorphic surface satisfying the constraint (4.74) is

$$aX + bY + cZ = 0. \quad (4.75)$$

This is actually the same as the  $AdS_5 \times S^5$  case. Thus the discussion is almost the same. We can expect that the single-particle BPS partition function has at least two zero modes because the phase space is  $\mathbb{C}P^2$ . And the total BPS partition function may be obtained by the summation over the  $X = 0$ ,  $Y = 0$ , and  $Z = 0$  configurations.

Let us check these expectations. The single-particle BPS partition function of the  $Z = 0$  configuration can be derived by the projection (4.61) with  $k = 2$  for (3.37):

$$\begin{aligned} i_{Z=0}^{\text{BPS}, \mathbb{Z}_2} &= \mathcal{P}_2 i_{\text{sp}}^{\text{BPS}} = \frac{x+y}{z(1-q^2x^2)(1-q^2y^2)} \\ &= \left(\frac{x}{z} + \frac{y}{z}\right) + \mathcal{O}(q^2). \end{aligned} \quad (4.76)$$

We found two zero modes. This is consistent with the fact that the phase space is  $\mathbb{C}P^2$ . We have already analyzed this situation in the last chapter, and we know that in this case, the summation over the  $X = 0$ ,  $Y = 0$ , and  $Z = 0$  configurations give the total BPS partition function. The BPS partition function of these configurations are related each other by the Weyl completion  $(x, y, z) \rightarrow (y, z, x)$  and  $(x, y, z) \rightarrow (z, x, y)$ .

A different point from the  $AdS_5 \times S^5$  case is the absence of a tachyonic mode. This can be understood as the effect of the orientifold. In the  $S^5$  case, the configuration  $X = c$  can exist, and this is the lower energy configuration than  $X = 0$ , where  $c$  is a non-zero constant. However, in the orientifold case, such configurations are forbidden by the orientifold projection. That is why a tachyonic mode is absent.

Now the finite  $N$  corrections to the BPS partition function of the single wrapping is given by

$$Z_{\mathbb{Z}_2}^{\text{D3}} = (qx)^N \text{Pexp}(i_{X=0}^{\text{BPS}, \mathbb{Z}_2}) + (qz)^N \text{Pexp}(i_{Y=0}^{\text{BPS}, \mathbb{Z}_2}) + (qz)^N \text{Pexp}(i_{Z=0}^{\text{BPS}, \mathbb{Z}_2}), \quad (4.77)$$

and the BPS partition function on the AdS side is

$$Z_{\mathbb{Z}_2}^{\text{AdS}} = Z_{\mathbb{Z}_2}^{\text{KK}}(1 + Z_{\mathbb{Z}_2}^{\text{D3}}), \quad (4.78)$$

where  $Z_{\mathbb{Z}_2}^{\text{KK}} = \text{Pexp}(I_0^{\mathbb{Z}_2} - 1)$ .  $Z_{\mathbb{Z}_2}^{\text{KK}} Z_{\mathbb{Z}_2}^{\text{D3}}$  must correspond to the Pfaffian sector of the BPS partition function of  $\mathcal{N} = 4$   $SO(2N)$  SYM. We checked the following relation up to  $N = 3$ :

$$Z_{S(N,2,1)}^{\text{CFT}} = Z_{\mathbb{Z}_2}^{\text{AdS}} + \mathcal{O}(q^{2N+2}). \quad (4.79)$$

### $k = 3, 4, 6$ S-folds

In fact, the constraint (4.74) restricts the possible form of the holomorphic function, that is, the possible shape of wrapped D3-branes. Then the most general single wrapped

D3-branes are represented by holomorphic surfaces

$$X = 0, \quad (4.80)$$

$$bY + cZ = 0, \quad (4.81)$$

and we cannot consider  $aX + bY + cZ = 0$  because it does not satisfy (4.74). The first configurations have the winding number  $m = -1$ , and the second one has  $m = 1$ .

First, let us see the configuration given by (4.80). The first task is to find the single-particle BPS partition function on the wrapped D3-brane  $X = 0$ . Actually, this is very easy to do. All we have to do is to perform the projection (4.61) to the single-particle BPS partition function of  $X = 0$ :

$$\frac{(qx)^{-1}}{(1-xy)(1-qz)}. \quad (4.82)$$

Thus we have

$$i_{X=0}^{\text{BPS}, \mathbb{Z}_k} = \mathcal{P}_k \left( \frac{(qx)^{-1}}{(1-xy)(1-qz)} \right) = \frac{1}{k} \sum_{m=0}^{k-1} \frac{(q\omega_k^{-1}x)^{-1}}{(1-q\omega_k y)(1-q\omega_k z)}. \quad (4.83)$$

Hence the total contribution is obtained by its plethystic exponential and the classical contribution  $(qx)^N$ :

$$Z_{X=0}^{\mathbb{Z}_k} = (qx)^N \text{Pexp}(i_{X=0}^{\text{BPS}, \mathbb{Z}_k}). \quad (4.84)$$

Let us check whether the tachyonic mode and zero modes exist or not for  $k = 3$  as an example. The expansion of (4.83) with  $k = 3$  is

$$i_{X=0}^{\text{BPS}, \mathbb{Z}_3} = \frac{(y^2 + yz + z^2)q}{x(1-q^3y^3)(1-q^3z^3)} = \frac{y^2 + yz + z^2}{x}q + \mathcal{O}(q^2). \quad (4.85)$$

Thus there are only zero modes. This is, in fact, the natural result because the presence of configurations with energy smaller than  $X = 0$  is forbidden by the constraint (4.74).

Second, we consider the configuration (4.81). Let us focus on the  $Y = 0$  by taking  $(b, c) = (1, 0)$ . Then the single-particle BPS partition function can be derived by the Weyl completion  $(x, y, z) \rightarrow (y, z, x)$  before the projection (4.61). The result is

$$i_{Y=0}^{\text{BPS}, \mathbb{Z}_k} = \mathcal{P}_k \left( \frac{(qy)^{-1}}{(1-qz)(1-qx)} \right) = \frac{1}{k} \sum_{m=0}^{k-1} \frac{(q\omega_k y)^{-1}}{(1-q\omega_k z)(1-q\omega_k^{-1}x)}. \quad (4.86)$$

Let us check the presence of tachyonic and zero modes in the single-particle BPS partition

function. The expansion of the  $k = 3$  case as an example is

$$i_{Y=0}^{\text{BPS}, \mathbb{Z}_3} = \frac{z + x^2 q + xz^2 q^2}{y(1 - q^3 z^3)(1 - q^3 x^3)} = \frac{z}{y} + \frac{x^2}{y} q + \mathcal{O}(q^2). \quad (4.87)$$

Now we found a zero mode. When we perform the plethystic exponential, this term with the classical contribution gives a factor

$$(qy)^N \text{Pexp} \left( \frac{z}{y} \right) = \frac{(qy)^N}{1 - \frac{z}{y}} = q^N (y^N + y^{N-1} z + \dots + yz^{N-1} + z^N + y^{-1} z^{N+1} + \dots). \quad (4.88)$$

This is evaluated in the region  $|\frac{z}{y}| < 1$ . The infinite series includes unphysical terms. However, they are canceled by the  $Z = 0$  contribution in the same fugacity region  $|\frac{z}{y}| < 1$ :

$$(qz)^N \text{Pexp} \left( \frac{y}{z} \right) = -q^N (y^{-1} z^{N+1} + \dots). \quad (4.89)$$

Then the summation over these terms gives

$$q^N (y^N + y^{N-1} z + \dots + yz^{N-1} + z^N). \quad (4.90)$$

These terms are summarized into the  $U(2)$  character  $\chi_N(y, z)$ . This is an analogy of the fact that the summation over the  $X = 0$ ,  $Y = 0$ , and  $Z = 0$  configurations gave the  $U(3)$  character in the orientifold and  $S^5$  cases. Here the summation over the contributions of  $Y = 0$  and  $Z = 0$  configurations gives all the single wrapping contributions with the winding number  $m = 1$ .

We have seen that the  $k = 3$  case as an example. We can also do the same analysis for  $k = 4, 6$  cases. Finally, we find the same expression of the final result as the orientifold and  $S^5$  case:

$$Z_{\mathbb{Z}_k}^{\text{D3}} = (qx)^N \text{Pexp}(i_{X=0}^{\text{BPS}, \mathbb{Z}_k}) + (qz)^N \text{Pexp}(i_{Y=0}^{\text{BPS}, \mathbb{Z}_k}) + (qz)^N \text{Pexp}(i_{Z=0}^{\text{BPS}, \mathbb{Z}_k}), \quad (4.91)$$

where the first term gives rise to  $m = -1$  sector, and other terms give  $m = 1$  sector. We can also check the following result up to  $N = 3$ .

$$Z_{S(N,3,1)}^{\text{CFT}} = Z_{\mathbb{Z}_k}^{\text{AdS}} + \mathcal{O}(q^{2N+1}), \quad (4.92)$$

$$Z_{S(N,4,1)}^{\text{CFT}} = Z_{\mathbb{Z}_k}^{\text{AdS}} + \mathcal{O}(q^{2N}), \quad (4.93)$$

$$Z_{S(N,6,1)}^{\text{CFT}} = Z_{\mathbb{Z}_k}^{\text{AdS}} + \mathcal{O}(q^{2N}). \quad (4.94)$$

Modes	$[j_L, j_R]_E^{(R, \bar{R}, R_Z)}$	$Y$	Contribution
$\bar{\phi}^{(l)}$	$[0, 0]_{l-1}^{([\frac{l}{2}], \frac{l}{2}, -1)}$	0	$q^{l-1}(u\eta^{-2})^{2R}v^{\frac{l}{2}-R+1}\eta^{-1}$
$\bar{\chi}^{(l)}$	$[0, \frac{1}{2}]_{l-\frac{1}{2}}^{([\frac{l}{2}], \frac{l-1}{2}, -\frac{1}{2})}$	1	$-q^l(u\eta^{-2})^{2R}v^{\frac{l-1}{2}-R+\frac{1}{2}}\eta^{-1}$
$\psi^{(l)}$	$[[\frac{1}{2}], 0]_{l-\frac{1}{2}}^{([\frac{l-1}{2}], \frac{l}{2}, -\frac{1}{2})}$	-1	$-q^{l-\frac{1}{2}}\chi_1^J(u\eta^{-2})^{2R}v^{\frac{l}{2}-R+\frac{1}{2}}$
$w^{(l)}$	$[[\frac{1}{2}], \frac{1}{2}]_l^{([\frac{l-2}{2}], \frac{l-1}{2}, 0)}$	0	$q^{l+\frac{1}{2}}\chi_1^J(u\eta^{-2})^{2R}v^{\frac{l-1}{2}-R}$
$F^{(l)}$	$[0, 0]_l^{([\frac{l-2}{2}], \frac{l}{2}, 0)}$	-2	$q^l(u\eta^{-2})^{2R}v^{\frac{l}{2}-R}\eta$
$\chi^{(l)}$	$[0, \frac{1}{2}]_{l+\frac{1}{2}}^{([\frac{l-2}{2}], \frac{l-1}{2}, \frac{1}{2})}$	-1	$-q^{l+1}(u\eta^{-2})^{2R}v^{\frac{l-1}{2}-R-\frac{1}{2}}\eta$

Table 4.8 The BPS massless modes arising on the wrapped D3-brane. Summing all contributions shown here, we find the refined single-particle index for the fluctuations of the wrapped D3-brane  $Z = 0$ .

### 4.5.2 Superconformal index

Here we consider the finite  $N$  corrections to the superconformal index of S-fold theories. Unlike the BPS partition function, there is no general formula to find the index of S-fold theories due to the lack of the Lagrangian, so our analysis is the first predictions of the index.

The strategy is almost the same as that of the BPS partition function. The only problem we have to solve is to obtain the refined single-particle index of wrapped D3-branes for  $X = 0$ ,  $Y = 0$ , and  $Z = 0$  configurations. Then all we have to do is to find the  $U(1)_Y$  charges for the fluctuation modes on wrapped D3-branes, which are listed in Table 3.3.

To find the  $U(1)_Y$  charges for massless modes on wrapped D3-branes, let us focus on the  $Z = 0$  configuration. We know all the massless modes shown in Table 3.3 and the structure of the supersymmetry multiplet shown in Fig. 3.1. So it is enough to find the  $U(1)_Y$  charge of  $\bar{\phi}^l$ . Because  $\bar{\phi}^l$  has already appeared in the BPS partition function, its transformation law is the  $\mathbb{Z}_k$  orbifold projection. It states that there is no  $U(1)_Y$  charge for  $\bar{\phi}^l$ . From this fact, we can find the  $U(1)_Y$  charge for all massless fields on  $Z = 0$ , as shown in Table 4.8.

The refined single-particle index of the  $Z = 0$  configuration, obtained from the information of Table 3.3 and Table 4.8, is then

$$\tilde{i}_{\text{sp}}^{Z=0}(\eta) = \frac{\frac{v}{\eta}q^{-1} - (y + y^{-1})q^{\frac{1}{2}} - (\frac{u}{\eta^2} + \frac{v}{u})q + (y + y^{-1})q^{\frac{3}{2}} + v(\eta^{-1} + \eta)q^2 - \eta q^3}{(1 - \frac{u}{\eta}q)(1 - \frac{v\eta}{u}q)}. \quad (4.95)$$

The single-particle index of the  $Z = 0$  configuration in a  $\mathbb{Z}_k$  S-fold background is

$$i_{Z=0}^{\mathbb{Z}_k} = \mathcal{P}_k \widetilde{i}_{\text{sp}}^{Z=0}(\eta). \quad (4.96)$$

For  $X = 0$  and  $Y = 0$  configurations, the refined single-particle index cannot be obtained by the ordinary Weyl completion for the refined single-particle index due to the existence of the  $\eta$  fugacity. This is because the corresponding generator to the  $\eta$  fugacity is  $-R_X + R_Y + R_Z - Y/2$ , and it does not commute with  $SU(3)_R$  generators  $R_X - R_Y$  and  $R_Y - R_Z$ . Instead of the  $SU(3)_R$  character, we define the ‘‘refined  $SU(3)_R$  character’’ by including the  $\eta$  fugacity as

$$\chi'_{(m,n)}(u, v, \eta) = \text{tr}[u^{R_X - R_Y} v^{R_Y - R_Z} \eta^{-R_X + R_Y + R_Z - Y/2}]. \quad (4.97)$$

Then the refined character corresponding to the representation to which  $(\overline{Q}_2, \overline{Q}_3, \overline{Q}_4)$  belong is

$$\chi'_{(1,0)}(u, v, \eta) = \frac{u}{\eta^2} + \frac{v}{u} + \frac{1}{v}. \quad (4.98)$$

This implies that our new Weyl completion should be defined as follows:

$$Z = 0 \rightarrow X = 0 : \left( \frac{u}{\eta^2}, \frac{v}{u}, \frac{1}{v} \right) \rightarrow \left( \frac{v}{u}, \frac{1}{v}, \frac{u}{\eta^2} \right), \quad (4.99)$$

$$Z = 0 \rightarrow Y = 0 : \left( \frac{u}{\eta^2}, \frac{v}{u}, \frac{1}{v} \right) \rightarrow \left( \frac{1}{v}, \frac{u}{\eta^2}, \frac{v}{u} \right). \quad (4.100)$$

By using this rule, we can obtain the refined single-particle index of  $X = 0$  and  $Y = 0$  configurations:

$$\widetilde{i}_{\text{sp}}^{X=0}(\eta) = \frac{\frac{\eta}{u}q^{-1} - (y + y^{-1})q^{\frac{1}{2}} - (\frac{v}{u} + \frac{1}{v})q + (y + y^{-1})q^{\frac{3}{2}} + u^{-1}(\eta + \eta^3)q^2 - \eta q^3}{(1 - \frac{v\eta}{u}q)(1 - \frac{\eta}{v}q)}, \quad (4.101)$$

$$\widetilde{i}_{\text{sp}}^{Y=0}(\eta) = \frac{\frac{u}{v\eta}q^{-1} - (y + y^{-1})q^{\frac{1}{2}} - (\frac{1}{v} + \frac{u}{\eta^2})q + (y + y^{-1})q^{\frac{3}{2}} + \frac{u}{v}(\eta^{-1} + \eta)q^2 - \eta q^3}{(1 - \frac{\eta}{v}q)(1 - \frac{u}{\eta}q)}. \quad (4.102)$$

In what follows, we see the orientifold case and  $k = 3, 4, 6$  S-fold cases separately.

### $k = 2$ orientifold

Actually, the flow of the discussion is the same as the BPS partition function. The most general configuration of the single wrapping is  $aX + bY + cZ = 0$ , and the summation over  $X, Y, Z = 0$  gives the  $SU(3)_R$  character corresponding to the fact that the phase space is

$\mathbb{C}P^2$ . Then the index of the wrapped D3-branes is given by

$$\mathcal{I}_{\mathbb{Z}_2}^{\text{D3}} = (qu)^N \text{Pexp}(\mathcal{P}_2 \tilde{i}_{\text{sp}}^{X=0}(\eta)) + \left(q \frac{v}{u}\right)^N \text{Pexp}(\mathcal{P}_2 \tilde{i}_{\text{sp}}^{Y=0}(\eta)) + \left(q \frac{1}{v}\right)^N \text{Pexp}(\mathcal{P}_2 \tilde{i}_{\text{sp}}^{Z=0}(\eta)). \quad (4.103)$$

Then the superconformal index on the orientifold background is

$$\mathcal{I}_{S(N,2,0)}^{\text{AdS}} = \mathcal{I}_{\mathbb{Z}_2}^{\text{KK}}(1 + \mathcal{I}_{\mathbb{Z}_2}^{\text{D3}}), \quad (4.104)$$

where  $\mathcal{I}_{\mathbb{Z}_2}^{\text{KK}} \mathcal{I}_{\mathbb{Z}_2}^{\text{D3}}$  should correspond to the Pfaffian sector on the CFT side. We checked the following relations up to  $N = 3$ :

$$\mathcal{I}_{SO(2N)}^{\text{CFT}} = \mathcal{I}_{S(N,2,0)}^{\text{AdS}} + \mathcal{O}(q^{2N+1}). \quad (4.105)$$

### $k = 3, 4, 6$ S-folds

Again, the procedure to find the finite  $N$  corrections to the index is the same as the BPS partition function. In this case there is two winding sectors  $m = -1$  and  $m = 1$ . The first one and second one correspond to  $X = 0$  and  $bY + cZ = 0$  configuration, respectively. Since the phase space of  $m = 1$  sector is  $\mathbb{C}P^1$ , the single-particle index for  $Y = 0$  and  $Z = 0$  has the corresponding zero mode, and summation over two configurations of  $m = 1$  gives the  $U(2)_R$  character  $\bar{\chi}_n(u^{-1}v, v^{-1})$  defined in (A.31). This fact reflects an  $\mathcal{N} = 3$  supersymmetry of S-fold theories for  $k = 3, 4, 6$ .

Our formula of the finite  $N$  corrections for a  $\mathbb{Z}_k$  S-fold background is now given by

$$\mathcal{I}_{S(N,k,0)}^{\text{AdS}} = \mathcal{I}_{\mathbb{Z}_k}^{\text{KK}}(1 + \mathcal{I}_{\mathbb{Z}_k}^{\text{D3}}), \quad (4.106)$$

$$\mathcal{I}_{\mathbb{Z}_k}^{\text{D3}} = (qu)^N \text{Pexp}(\mathcal{P}_k \tilde{i}_{\text{sp}}^{X=0}(\eta)) + \left(q \frac{v}{u}\right)^N \text{Pexp}(\mathcal{P}_k \tilde{i}_{\text{sp}}^{Y=0}(\eta)) + \left(q \frac{1}{v}\right)^N \text{Pexp}(\mathcal{P}_k \tilde{i}_{\text{sp}}^{Z=0}(\eta)). \quad (4.107)$$

This formula gives the prediction of the index for S-fold theories up to an order from which the double wrapping starts.

Let us make sure that the index is indeed written by the  $U(2)_R$  character as evidence of an  $\mathcal{N} = 3$  supersymmetry. We take up  $S(3, 3, 0)$  as an example here. Then our formula

gives

$$\begin{aligned}
\mathcal{I}_{S(3,3,0)}^{\text{AdS}} = & 1 + u\bar{\chi}_1 q^2 - u\chi_1^J q^{\frac{5}{2}} + (-1 + 2u^3 - u\bar{\chi}_2 + 2\bar{\chi}_3)q^3 \\
& + \chi_1^J(2u\bar{\chi}_1 - 2\bar{\chi}_2)q^{\frac{7}{2}} + (-u - u\chi_2^J + 3\bar{\chi}_1 - 2u^3\bar{\chi}_1 - 2u^{-1}\bar{\chi}_2 + 4u^2\bar{\chi}_2)q^4 \\
& + \chi_1^J(-2 + 2u^3 + 2\frac{1}{u}\bar{\chi}_1 - 4u^2\bar{\chi}_1 - u\bar{\chi}_2 + 2\bar{\chi}_3)q^{\frac{9}{2}} \\
& + (\chi_2^J(2u\bar{\chi}_1 - 2\bar{\chi}_2) + 6u^2 - 4u\bar{\chi}_1 + 4u^4\bar{\chi}_1 - 4u^2\bar{\chi}_3 + 4u\bar{\chi}_4)q^5 \\
& + (5u\chi_1^J - 4u^4\chi_1^J - u\chi_3^J - \chi_1^J\bar{\chi}_1 - 2u^3\chi_1^J\bar{\chi}_1 - 2u^{-1}\chi_1^J\bar{\chi}_2 \\
& \quad + 9u^2\chi_1^J\bar{\chi}_2 - 6u\chi_1^J\bar{\chi}_3)q^{\frac{11}{2}} \\
& + (2 - 6u^3 + 4u^6 + 2u^3\chi_2^J - 4u^{-1}\bar{\chi}_1 - 5u^2\bar{\chi}_1 + 2u^{-1}\chi_2^J\bar{\chi}_1 \\
& \quad - 6u^2\chi_2^J\bar{\chi}_1 + 3u^{-2}\bar{\chi}_2 + 14u\bar{\chi}_2 - 6u^4\bar{\chi}_2 + u\chi_2^J\bar{\chi}_2 - 8\bar{\chi}_3 \\
& \quad + 8u^3\bar{\chi}_3 + 2\chi_2^J\bar{\chi}_3 + u^{-1}\bar{\chi}_4 - 4u\bar{\chi}_5 + 4\bar{\chi}_6)q^6 \\
& + (6u^{-1}\chi_1^J + 3u^2\chi_1^J + u^2\chi_3^J - 3u^{-2}\chi_1^J\bar{\chi}_1 - 17u\chi_1^J\bar{\chi}_1 \\
& \quad + 12u^4\chi_1^J\bar{\chi}_1 + 2u\chi_3^J\bar{\chi}_1 + 16\chi_1^J\bar{\chi}_2 - 12u^3\chi_1^J\bar{\chi}_2 - 2\chi_3^J\bar{\chi}_2 \\
& \quad - 4u^{-1}\chi_1^J\bar{\chi}_3 - 6u^2\chi_1^J\bar{\chi}_3 + 12u\chi_1^J\bar{\chi}_4 - 5\chi_1^J\bar{\chi}_5)q^{\frac{13}{2}} + \mathcal{O}(q^7). \tag{4.108}
\end{aligned}$$

This index is never unified into the  $SU(3)_R$  character. Thus a theory  $S(3, 3, 0)$  indeed has an  $\mathcal{N} = 3$  supersymmetry.

## 4.6 Consistency check

Let us check the consistency with some known results. We can do two checks. The first one is to check the supersymmetry enhancement in terms of the index. If the enhancement occurs, the index should be unified into the  $SU(3)_R$  characters rather than the  $U(2)_R$  character. The second check is to compare our result of  $S(3, 3, 0)$  with Zafrir's result calculated recently. He proposed an  $\mathcal{N} = 1$  model is dual to  $S(3, 3, 0)$ , and calculated the index of this model. So his calculation should agree with our prediction given in (4.108).

### 4.6.1 Supersymmetry enhancement

First, let us consider the supersymmetry enhancement of rank one and two S-fold theories. It is expected from the general discussion of an  $\mathcal{N} = 3$  superconformal algebra, and Aharony and Tachikawa conjectured that the rank one and two S-fold theories with  $k = 3, 4, 6$  are equivalent to the  $\mathcal{N} = 4$  SYM with the gauge group  $U(1)$ ,  $SU(3)$ ,  $SO(5)$  and  $G_2$ .

Here we focus on the  $S(2, 6, 0)$  as an example. It is expected that this theory is equivalent

to the  $\mathcal{N} = 4$   $G_2$  SYM. Our formula (4.107) gives the following amazing result:

$$\begin{aligned}
\mathcal{I}_{S(2,6,0)}^{\text{AdS}} &= 1 + \underbrace{(u^2 + u\bar{\chi}_1 + \bar{\chi}_2)}_{\chi(2,0)} q^2 - \chi_1^J \underbrace{(u + \bar{\chi}_1)}_{\chi(1,0)} q^{\frac{5}{2}} - \underbrace{(u^{-1}\bar{\chi}_1 + u^2\bar{\chi}_1 + u\bar{\chi}_2)}_{\chi(1,1)-1} q^3 \\
&+ \chi_1^J \underbrace{(u^{-1} + u^2 + 2u\bar{\chi}_1 + \bar{\chi}_2)}_{\chi(0,1)+\chi(2,0)} q^{\frac{7}{2}} \\
&+ (-u\chi_2^J + \bar{\chi}_1 + u^3\bar{\chi}_1 - \chi_2^J\bar{\chi}_1 + 2u^2\bar{\chi}_2 + u\bar{\chi}_3)q^4 \\
&- \chi_1^J(2 + u^3 + u^{-1}\bar{\chi}_1 + 3u^2\bar{\chi}_1 + 3u\bar{\chi}_2)q^{\frac{9}{2}} \\
&+ (-u^{-1} + u^{-1}\chi_2^J + u^2\chi_2^J + 3u\chi_2^J\bar{\chi}_1 - 3\bar{\chi}_2 - 2u^3\bar{\chi}_2 + \chi_2^J\bar{\chi}_2 - 2u^2\bar{\chi}_3 - u\bar{\chi}_4)q^5 \\
&+ ((3u + 7\bar{\chi}_1 + 4u^3\bar{\chi}_1 + 5u^2\bar{\chi}_2 + 4u\bar{\chi}_3)\chi_1^J - (u + \bar{\chi}_1)\chi_3^J)q^{\frac{11}{2}} \\
&+ (-4 - 2u^3 + u^6 - 5\chi_2^J - 2u^3\chi_2^J + (3u^{-1} + u^5 - u^{-1}\chi_2^J - 5u^2\chi_2^J)\bar{\chi}_1 \\
&+ (-u + 2u^4 - 6u\chi_2^J)\bar{\chi}_2 + (2 + 4u^3)\bar{\chi}_3 + 2u^2\bar{\chi}_4 + u\bar{\chi}_5 + \bar{\chi}_6)q^6 + \mathcal{O}(q^{\frac{13}{2}}).
\end{aligned} \tag{4.109}$$

The first few terms are indeed summarized into the  $SU(3)_R$  characters. We expect that the double wrapping starts from  $q^4$  because the double wrapping has an order of  $2N$  ( $N = 2$ ) energy. If we take into account the multiple wrapping, the index would be written in terms of  $SU(3)_R$  characters more. Note that the summarizing way is quite non-trivial. In the level of the phase space of holomorphic surfaces,  $\mathcal{N} = 4$  supersymmetry could not appear. However, the enhancement is indeed present. We can also show that

$$\mathcal{I}_{S(2,6,0)}^{\text{AdS}} = \mathcal{I}_{G_2}^{\text{CFT}} + \mathcal{O}(q^4). \tag{4.110}$$

Thus, we confirmed the Aharony-Tachikawa conjecture in the terms of the superconformal index.

We also confirmed the following relations:

$$\mathcal{I}_{S(1,3,0)}^{\text{AdS}} = \mathcal{I}_{U(1)}^{\text{CFT}} + \mathcal{O}(q^3), \tag{4.111}$$

$$\mathcal{I}_{S(1,4,0)}^{\text{AdS}} = \mathcal{I}_{U(1)}^{\text{CFT}} + \mathcal{O}(q^2), \tag{4.112}$$

$$\mathcal{I}_{S(1,6,0)}^{\text{AdS}} = \mathcal{I}_{U(1)}^{\text{CFT}} + \mathcal{O}(q^2), \tag{4.113}$$

$$\mathcal{I}_{S(2,3,0)}^{\text{AdS}} = \mathcal{I}_{SU(3)}^{\text{CFT}} + \mathcal{O}(q^5), \tag{4.114}$$

$$\mathcal{I}_{S(2,4,0)}^{\text{AdS}} = \mathcal{I}_{SO(5)}^{\text{CFT}} + \mathcal{O}(q^4). \tag{4.115}$$

All results are consistent with the emergence of the double wrapping.

### 4.6.2 Comparison with Zafrir's result

Very recently, Zafrir discovered certain Lagrangian theories that flow to  $\mathcal{N} = 3$  SCFTs with a free chiral field [21]. Since the superconformal index is an RG flow invariant, it

is possible to calculate the index of the system, including an  $\mathcal{N} = 3$  SCFT and a free field. Then we need to remove the latter contribution. This can be done by using the procedure given in [43]. Note that the procedure given by Zafrir is not applicable to all  $\mathcal{N} = 3$  theories. He showed the cases of  $S(3, 1, 1)$  and  $S(3, 3, 0)$ . The latter case is the rank 3  $\mathbb{Z}_3$  S-fold theory with the trivial torsion, so we compare our result (4.108) with the result given in [21]. The Zafrir's result of the  $S(3, 3, 0)$  theory is given by [21]

$$\begin{aligned} \mathcal{I}_{\text{Zafrir}} = & 1 + 2(pq)^{\frac{2}{3}} - (pq)^{\frac{1}{3}}(p+q) + 6pq - 2(pq)^{\frac{2}{3}}(p+q) + 6(pq)^{\frac{4}{3}} - (pq)^{\frac{1}{3}}(p^2+q^2) \\ & + (pq)(p+q) + 8(pq)^{\frac{5}{3}} - 2(pq)^{\frac{2}{3}}(p^2+q^2) - 9(pq)^{\frac{4}{3}}(p+q) - (pq)^{\frac{1}{3}}(p^3+q^3) \\ & + 29(pq)^2 + 5(pq)(p^2+q^2) - 6(pq)^{\frac{5}{3}}(p+q) - (pq)^{\frac{2}{3}}(p^3+q^3) + \dots \end{aligned} \quad (4.116)$$

This is written in the ‘‘standard notation’’ [44, 45]. In order to compare it with (4.108), we need the following replacement from the standard notation  $(p, q)$  to our notation  $(q, y, u, v)$  with  $u = v = 1$ :

$$p \rightarrow q^{\frac{3}{2}}y, \quad q \rightarrow q^{\frac{3}{2}}y^{-1}. \quad (4.117)$$

Then we find the agreement

$$\mathcal{I}_{S(3,3,0)}|_{u=v=1} = \mathcal{I}_{\text{Zafrir}} + \mathcal{O}(q^6), \quad (4.118)$$

where  $\mathcal{I}_{S(3,3,0)}$  is given in (4.108). The error is consistent with the double wrapping contributions. This is the first non-trivial confirmation of our predictions for S-fold theories and ensures the correctness of our calculations of the finite  $N$  corrections to the index for S-fold theories.

## Chapter 5

# Conclusions and Discussions

In this chapter, we give the conclusions of this thesis and the discussions.

In this thesis, we developed the calculation method of the superconformal index on the AdS side in the finite  $N$  region of the AdS/CFT correspondence. Then we applied our method to the S-fold theories whose Lagrangian is not known. For this purpose, we started from the review of basic concepts of the partition function, Witten index, superconformal symmetry, superconformal index, and the BPS partition function in Chapter 1.

In Chapter 2, we reviewed  $\mathcal{N} = 4$  SYM and type IIB string theory to discuss the AdS/CFT correspondence between these theories. We also gave the concrete expressions of the superconformal index and the BPS partition function of  $\mathcal{N} = 4$   $U(N)$  SYM. Then we gave the precise statement of the AdS/CFT correspondence. We also performed the calculation of the index and the BPS partition function on the AdS side in the large  $N$  limit and confirmed the agreement with those on the CFT side.

In Chapter 3, we studied the finite  $N$  corrections to the BPS partition function and the superconformal index. It is expected that D3-branes wrapped on three-cycles in  $S^5$  give the finite  $N$  corrections [17, 19, 29]. Then we analyzed the single wrapped D3-brane by considering massless fields living on the wrapped D3-brane. First, we considered the finite  $N$  corrections to the BPS partition function to study the structure of the finite  $N$  corrections on the AdS side. We calculated the single-particle BPS partition function of three single wrapped D3-branes whose configurations are  $X = 0$ ,  $Y = 0$ , and  $Z = 0$ . We found that there are a tachyonic term and two zero modes. The tachyonic term is the negative power of the fugacity  $q$ , and we needed the special treatment as

$$\text{Pexp}(q^{-1}) = \frac{1}{1 - q^{-1}} = -\frac{q}{1 - q} = -q\text{Pexp}(q). \quad (5.1)$$

The zero modes are related to the  $U(3)_R$  symmetry and have the unphysical infinite contributions. These contributions are canceled each other by summing the contributions from  $X = 0$ ,  $Y = 0$ , and  $Z = 0$ . The significant observation is that the summation of these three contributions is just the Weyl character formula. Then we proposed the

formula which gives the finite  $N$  corrections to the BPS partition function as

$$Z_{\text{finite } N}^{\text{AdS}} = Z_{\text{large } N}^{\text{AdS}}(1 + Z_{X=0}^{\text{D3}} + Z_{Y=0}^{\text{D3}} + Z_{Z=0}^{\text{D3}}) + \mathcal{O}(q^{2N+5}). \quad (5.2)$$

We confirmed that results obtained by this formula agree with the results on the CFT side up to  $q^{2N+5}$ . It is expected that the error comes from the double wrapping contributions.

After the computation of the BPS partition function, we considered the superconformal index. The same technique as the case of the BPS partition function can be applied, and we proposed a similar formula to (5.2):

$$\mathcal{I}_{\text{finite } N}^{\text{AdS}} = \mathcal{I}_{\text{large } N}^{\text{AdS}}(1 + \mathcal{I}_{X=0}^{\text{D3}} + \mathcal{I}_{Y=0}^{\text{D3}} + \mathcal{I}_{Z=0}^{\text{D3}}) + \mathcal{O}(q^{2N+4}). \quad (5.3)$$

We also confirmed that the results given by this formula on the AdS side agree with the results on the CFT side up to the expected order of the fugacity  $q$ .

In Chapter 4, we investigated the orientifold theories and the S-fold theories. First, we reviewed the orientifold in type IIB string theory, and after that, we defined the S-fold action and the S-fold theories. We constructed the BPS partition functions for S-fold theories by using the oscillator formalism that we developed in Chapter 2. Moreover, we applied our formula (5.3) with the minor modification due to the S-fold invariance. In [20], it is expected that the rank one S-fold theories are equivalent to  $\mathcal{N} = 4$   $U(1)$  Maxwell theory and rank two S-fold theories for  $k = 3, 4, 6$  are equivalent to  $\mathcal{N} = 4$  SYM with  $SU(3)$ ,  $SO(5)$ , and  $G_2$  gauge groups, respectively (Aharony-Tachikawa (AT) conjecture). We confirmed the agreement of the index for these S-fold theories with the index for these  $\mathcal{N} = 4$  theories. The UV Lagrangian for  $S(3, 3, 0)$  S-fold theories was found, and the index of this theory was calculated by Zafrir [21]. So we finally confirmed the agreement of our prediction with the result given in [21].

There are many unsolved problems. First, we have no clear physical explanation of the treatment of the tachyonic mode (5.1). To ensure the convergence of the left-hand side of (5.1), we need the condition  $q > 1$ , while we need  $q < 1$  for the right-hand side of (5.1). Up to now, all we can do is to regard this treatment as the analytic continuation. We hope that there is a certain physical meaning of this treatment.

Second, the multiple wrapping contributions are not included in the formula (5.3). For AdS/CFT regarding  $\mathcal{N} = 4$   $U(N)$  SYM, we expect that contributions of the  $n$ -ple wrapped D3-branes may be obtained by considering the  $U(n)$  gauge theory on the wrapped D3-branes. However, it is necessary to perform the gauge integral like (3.76), and the pole selection rule of this integral is unclear.

If we consider the Schur limit [46] of the superconformal index defined by

$$\mathcal{I}_{\text{Schur}}(q, u) = \lim_{y \rightarrow q^{-\frac{1}{2}}, v \rightarrow 1} \mathcal{I}(q, y, u, v), \quad (5.4)$$

the structure of the gauge integral becomes much simpler. The index (5.4) is called the Schur index. Then the analysis of the multiple wrapped D3-branes is simplified, and we

performed the analysis in the author's and his collaborators' paper [47]. Our analysis shows that there are “the intersection string contributions” as well as the multiple wrapping contributions. Note that in the Schur limit, the contributions from the configurations including  $Z$  vanish. Let us consider the configuration  $X^{n-k}Y^k = 0$ . Then we have the  $U(n-k) \times U(k)$  gauge theory. The intersection string between  $X^{n-k} = 0$  and  $Y^k = 0$  corresponds to the bi-fundamental field of the  $U(n-k) \times U(k)$  theory. Roughly speaking, the contributions of the  $n$ -ple wrapped D3-branes is then

$$\mathcal{I}_{n,N}^{\text{D3}} = q^{nN} \sum_{k=0}^n \int_{U(n-k) \times U(k)} d\mu \text{Pexp}(i_{\text{sp}}^{X=0} \chi_{\text{adj}}^{U(n-k)} + i_{\text{sp}}^{Y=0} \chi_{\text{adj}}^{U(k)} + i_{\text{sp}}^{\text{int}} \chi_{\text{bi-fund}}), \quad (5.5)$$

where  $i_{\text{sp}}^{\text{int}}$  is the single-particle index of the contributions from the intersection string. We confirmed that the results up to  $n = 4$  completely agree with the CFT results [47]. We expect that the same structure holds even for the superconformal index.

There are also various extensions of our analysis [22] that are not contained in this thesis. These extensions were given by the author's and his collaborators' papers [48–50].

The significant benefit of our method to compute the finite  $N$  corrections is that it is applicable for any AdS/CFT in principle. The simplest extension is the quiver gauge theories realized on D3-branes put on Abelian orbifolds. AdS/CFT for orbifold  $S^5/\Gamma$  was suggested in [51, 52]. Thus we can apply our formula to this AdS/CFT to calculate the superconformal index. Since the quiver gauge theories have the explicit Lagrangian, the index is calculable. That is, our task is the confirmation of the agreement of the index on both sides. In particular, the D3-branes wrapped on the non-trivial three-cycles in  $S^5/\Gamma$  correspond to the baryonic operators defined as operators including the determinant operator. This situation is quite similar to the S-fold theories. Then, the wrapped D3-brane contributions may be obtained by an appropriate projection of  $\mathcal{I}^{\text{D3}}$  associated with the orbifold. In fact, our analysis with the orbifold projection does work, and the agreement up to the double wrapping contributions was confirmed in [48].

We also generalized the analysis of the orbifold quiver gauge theories to the toric quiver gauge theories [49]. The toric quiver gauge theories are realized on D3-branes put on a toric Calabi-Yau (CY) three-fold. The realized gauge theory depends on toric CY three-folds, and there is a systematic prescription [53, 54] to determine the gauge theory from the toric data of the CY three-fold. The corresponding AdS dual is given by type IIB string theory on  $AdS_5 \times SE_5$ , where  $SE_5$  is the five-dimensional Sasaki-Einstein manifold. The simple example is the Klebanov-Witten theory [55] and its AdS dual is type IIB string theory on  $AdS_5 \times T^{1,1}$ . The index is also calculable for toric quiver gauge theories, so the task is also the confirmation of the agreement of the index on both sides. Note that  $\mathcal{N} = 4$   $U(N)$  SYM and the orbifold quiver gauge theories are simple examples of toric quiver gauge theories. Thus we can guess the relationship between our method presented in this thesis and the toric data. In fact, we proposed the generalization of our method to the toric CY cases and showed that all the results are consistent with the CFT results [49].

Our method is also applicable in other dimensions. In [50], we analyzed the

three-dimensional Aharony-Bergman-Jafferis-Maldacena (ABJM) theory [56] and the six-dimensional (6d)  $\mathcal{N} = (2, 0)$  theories. The ABJM theory is realized on M2-branes in M-theory, while 6d  $\mathcal{N} = (2, 0)$  theories are realized on M5-branes. The corresponding AdS duals are M-theory on  $AdS_4 \times S^7$  and  $AdS_7 \times S^4$ . We calculated the finite  $N$  corrections to the index as contributions from M5-branes in  $S^7$ . Because the Lagrangian of the ABJM theory is known, and we confirmed the agreement of the index on both sides. On the other hand, the Lagrangian of 6d  $\mathcal{N} = (2, 0)$  theories are unknown, so we predicted the index from the contributions of M2-branes in  $S^4$ . For the rank one theory (realized on one M5-brane), it is known that the theory is free, and we can calculate the index. In this case, we confirmed the agreement of the index on both sides.

All of these analyses show that our method is very powerful in calculating the index for various AdS/CFTs.

There are various future directions. Up to now, our results of S-fold theories are still the prediction except for few examples. Thus the check of our results is important. A way to do it is to use the  $\mathcal{N} = 2$  SCFT/chiral algebra correspondence [57]. This correspondence comes from the fact that the four-dimensional  $\mathcal{N} = 2$  superconformal algebra contains the two-dimensional chiral algebra. Concretely, the Schur index of an  $\mathcal{N} = 2$  SCFT is equivalent to the vacuum character of the corresponding two-dimensional chiral algebra [57]. This means that if we identify the chiral algebra corresponding to S-fold theories, we may be able to calculate the Schur index of S-fold theories from the vacuum character. Our prediction for the Schur index is also given in [22], so we can compare these results. Note that the chiral algebra corresponding to rank one S-fold theories were already given in [58]. However, the rank one S-fold theory with the trivial torsion is the free theory, and we need the chiral algebras corresponding to higher rank S-fold theories.

Another future direction is to apply our method to AdS/CFT regarding AD theories. Some of the AdS dual to AD theories are given in [59, 60]. Then we may be able to calculate the finite  $N$  corrections to the index as well as the contributions of KK modes. Another interesting example is AdS/CFT regarding  $T_N$  theories [61]. The superconformal index of  $T_N$  theories has not been given yet, and we may be able to calculate the index for these theories by using their AdS dual given in [62].

# Appendix A

## Conventions and Notations

In this appendix we summarize the spinor conventions for four-dimensional theories and the notations for group theory.

### A.1 Spinor convention for four-dimensional theories

In this section we would like to explain our spinor notation. Our spinor convention is almost the same as that used in [63].

In four-dimensional (4d) theories, the four-vector  $x^\mu$  ( $\mu = 0, 1, 2, 3$ ) is the position vector. The flat Minkowski metric is denoted by  $\eta_{\mu\nu}$ . We use the following convention:

$$\eta_{\mu\nu} = \text{diag}(-1, 1, 1, 1). \quad (\text{A.1})$$

The 4d gamma matrices  $\gamma^\mu$  satisfy the Clifford algebra

$$\{\gamma^\mu, \gamma^\nu\} = -2\eta^{\mu\nu}. \quad (\text{A.2})$$

Let  $\psi_\alpha$  be a left-handed two component Weyl spinor and let  $\bar{\chi}^{\dot{\alpha}}$  be a right-handed two-component Weyl spinor. The Hermite conjugate of Weyl spinors are

$$(\psi_\alpha)^\dagger = \bar{\psi}_{\dot{\alpha}}, \quad (\bar{\chi}^{\dot{\alpha}})^\dagger = \chi^\alpha. \quad (\text{A.3})$$

The contractions of spinors are given by

$$\psi\xi = \psi^\alpha \xi_\alpha, \quad \bar{\chi}\bar{\zeta} = \bar{\chi}_{\dot{\alpha}} \bar{\zeta}^{\dot{\alpha}}. \quad (\text{A.4})$$

The anti-symmetric epsilon tensor raises and lowers the spinor indices as

$$\psi^\alpha = \epsilon^{\alpha\beta} \psi_\beta, \quad \psi_\alpha = \epsilon_{\alpha\beta} \psi^\beta, \quad (\text{A.5})$$

$$\bar{\chi}_{\dot{\alpha}} = \epsilon_{\dot{\alpha}\dot{\beta}} \bar{\chi}^{\dot{\beta}}, \quad \bar{\chi}^{\dot{\alpha}} = \epsilon^{\dot{\alpha}\dot{\beta}} \bar{\chi}_{\dot{\beta}}, \quad (\text{A.6})$$

where the anti-symmetric epsilon tensor satisfies

$$\epsilon_{12} = \epsilon^{21} = -1, \quad (\text{A.7})$$

$$\epsilon^{12} = \epsilon_{21} = 1 \quad (\text{A.8})$$

$$\epsilon_{\alpha\beta}\epsilon^{\beta\gamma} = \epsilon^{\gamma\beta}\epsilon_{\beta\alpha} = \delta_{\alpha}^{\gamma}, \quad (\text{A.9})$$

$$\epsilon_{\dot{\alpha}\dot{\beta}}\epsilon^{\dot{\beta}\dot{\gamma}} = \epsilon^{\dot{\gamma}\dot{\beta}}\epsilon_{\dot{\beta}\dot{\alpha}} = \delta_{\dot{\alpha}}^{\dot{\gamma}}. \quad (\text{A.10})$$

The four-Pauli matrices  $\sigma^{\mu}$  and  $\bar{\sigma}^{\mu}$  are defined by

$$(\sigma^{\mu})_{\alpha\dot{\alpha}} = (1, \sigma^i), \quad (\bar{\sigma}^{\mu})^{\dot{\alpha}\alpha} = (1, -\sigma^i), \quad (\text{A.11})$$

where

$$\sigma^1 = \begin{pmatrix} 0 & 1 \\ 1 & 0 \end{pmatrix}, \quad \sigma^2 = \begin{pmatrix} 0 & -i \\ i & 0 \end{pmatrix}, \quad \sigma^3 = \begin{pmatrix} 1 & 0 \\ 0 & -1 \end{pmatrix}. \quad (\text{A.12})$$

The four-Pauli matrices satisfy

$$(\sigma^{\mu})_{\alpha\dot{\alpha}}(\bar{\sigma}_{\mu})^{\dot{\beta}\beta} = -2\delta_{\alpha}^{\beta}\delta_{\dot{\alpha}}^{\dot{\beta}}. \quad (\text{A.13})$$

The gamma matrices  $\gamma^{\mu}$  are related with the four-Pauli matrices as

$$\gamma^{\mu} = \begin{pmatrix} 0 & \sigma^{\mu} \\ \bar{\sigma}^{\mu} & 0 \end{pmatrix}. \quad (\text{A.14})$$

It is convenient to define the anti-symmetric gamma and four-Pauli matrices as

$$\gamma^{\mu\nu} = \frac{1}{2}[\gamma^{\mu}, \gamma^{\nu}] = \begin{pmatrix} \sigma^{\mu\nu} & 0 \\ 0 & \bar{\sigma}^{\mu\nu} \end{pmatrix}, \quad (\text{A.15})$$

$$(\sigma^{\mu\nu})_{\alpha}^{\beta} = \frac{1}{2}(\sigma^{\mu}\bar{\sigma}^{\nu} - \sigma^{\nu}\bar{\sigma}^{\mu})_{\alpha}^{\beta}, \quad (\text{A.16})$$

$$(\bar{\sigma}^{\mu\nu})^{\dot{\alpha}}_{\dot{\beta}} = \frac{1}{2}(\bar{\sigma}^{\mu}\sigma^{\nu} - \bar{\sigma}^{\nu}\sigma^{\mu})^{\dot{\alpha}}_{\dot{\beta}}. \quad (\text{A.17})$$

The four-component Dirac spinor  $\Psi_D$  is made of a left-handed Weyl spinor  $\psi_{\alpha}$  and a right-handed Weyl spinor  $\bar{\chi}^{\dot{\alpha}}$  as

$$\Psi_D = \begin{pmatrix} \psi_{\alpha} \\ \bar{\chi}^{\dot{\alpha}} \end{pmatrix}. \quad (\text{A.18})$$

The Dirac conjugate  $\bar{\Psi}_D$  is defined as

$$\bar{\Psi}_D = \Psi_D^{\dagger}\gamma^0. \quad (\text{A.19})$$

The Majorana condition is defined by

$$\bar{\Psi}_D = \Psi_D^T C, \quad C = \begin{pmatrix} -\epsilon^{\alpha\beta} & 0 \\ 0 & -\epsilon_{\dot{\alpha}\dot{\beta}} \end{pmatrix} = -i\gamma^2\gamma^0. \quad (\text{A.20})$$

The Majorana spinor satisfying the Majorana condition is

$$\Psi_M = \begin{pmatrix} \psi_\alpha \\ \bar{\psi}^{\dot{\alpha}} \end{pmatrix}. \quad (\text{A.21})$$

The Dirac and Majorana kinetic terms are given by

$$\mathcal{L}_D = i\bar{\Psi}_D\gamma^\mu\partial_\mu\Psi_D \sim i\bar{\psi}\bar{\sigma}^\mu\partial_\mu\psi + i\bar{\chi}\bar{\sigma}^\mu\partial_\mu\chi, \quad (\text{A.22})$$

$$\mathcal{L}_M = \frac{i}{2}\bar{\Psi}_M\gamma^\mu\partial_\mu\Psi_M \sim i\bar{\psi}\bar{\sigma}^\mu\partial_\mu\psi, \quad (\text{A.23})$$

where the symbol “ $\sim$ ” means that we neglect total derivatives.

## A.2 Notations of group theory

Here we would like to define and fix the notations for group theory. We only consider Lie groups.

### A.2.1 Dynkin label

Let us consider a Lie group  $G$  with simple roots  $\alpha^j$  ( $j = 1, \dots, \text{rank}G$ ). Let  $\mu^j$  be the fundamental weight satisfying

$$\frac{2\alpha^j \cdot \mu^k}{(\alpha^j)^2} = \delta_{jk}. \quad (\text{A.24})$$

Then the highest weight of an arbitrary irreducible representation of a Lie group  $G$  can always be written as

$$\mu = \sum_{j=1}^{\text{rank}G} \ell^j \mu^j, \quad (\text{A.25})$$

where  $\ell^j$  is a non-negative integer called the Dynkin label. Thus we can label an irreducible representation by the Dynkin label. We often use the notation

$$(\ell^1, \dots, \ell^{\text{rank}G}) \quad (\text{A.26})$$

to express an irreducible representation with the highest weight  $\mu = \sum_j \ell^j \mu^j$  of  $G$ .

### A.2.2 Character formula

A character  $\chi_{\mathcal{R}}(u)$  of a representation  $\mathcal{R}$  of a Lie group  $G$  is defined by

$$\chi_{\mathcal{R}}(u) = \text{tr}_{\mathcal{R}} \left( \prod_{j=1}^{\text{rank}G} u_j^{H_j} \right), \quad (\text{A.27})$$

where  $H_j$  is the Cartan generator of  $G$ . There is a formula to calculate the character for a given representation  $\mathcal{R}$  with the highest weight  $\mu$ . It is given by

$$\chi_{\mathcal{R}}(u) = \frac{\sum_{\sigma \in \mathcal{W}} \text{sign}(\sigma) u^{\sigma(\mu+\rho)}}{\prod_{\alpha \in R_+} (u^{\frac{\alpha}{2}} - u^{-\frac{\alpha}{2}})}, \quad (\text{A.28})$$

where  $R_+$  is a set of positive roots and  $\mathcal{W}$  is a set of Weyl reflections.  $\rho$  is defined by

$$\rho = \frac{1}{2} \sum_{\alpha \in R_+} \alpha. \quad (\text{A.29})$$

We used the vector notation

$$u^\mu = \prod_{j=1}^{\text{rank}G} u_j^{\mu_j}. \quad (\text{A.30})$$

The formula (A.28) is called the Weyl character formula.

For convenience, we show the Weyl character formula for  $U(2)$  and  $U(3)$ . The  $U(2)$  character  $\bar{\chi}_n(a, b)$  is given by

$$\bar{\chi}_n(a, b) = \frac{a^{n+1} - b^{n+1}}{a - b}. \quad (\text{A.31})$$

The  $U(3)$  character  $\bar{\chi}_{(m,n)}(a, b, c)$  is given by

$$\bar{\chi}_{(m,n)}(a, b, c) = -\frac{abc}{(a-b)(b-c)(c-a)} \begin{vmatrix} a^{m+1} & 1 & a^{-n-1} \\ b^{m+1} & 1 & b^{-n-1} \\ c^{m+1} & 1 & c^{-n-1} \end{vmatrix}. \quad (\text{A.32})$$

Then the  $SU(2)$  character  $\chi_n(u)$  and the  $SU(3)$  character  $\chi_{(m,n)}(u, v)$  are given by

$$\chi_n(u) = \bar{\chi}_n(u, u^{-1}), \quad (\text{A.33})$$

$$\chi_{(m,n)}(u, v) = \bar{\chi}_{(m,n)}(u, u^{-1}v, v^{-1}). \quad (\text{A.34})$$

# Bibliography

- [1] L. Brink, J. H. Schwarz and J. Scherk, “Supersymmetric Yang-Mills Theories,” Nucl. Phys. B **121**, 77-92 (1977) doi:10.1016/0550-3213(77)90328-5
- [2] F. Gliozzi, J. Scherk and D. I. Olive, “Supersymmetry, Supergravity Theories and the Dual Spinor Model,” Nucl. Phys. B **122**, 253-290 (1977) doi:10.1016/0550-3213(77)90206-1
- [3] N. Seiberg and E. Witten, “Electric - magnetic duality, monopole condensation, and confinement in N=2 supersymmetric Yang-Mills theory,” Nucl. Phys. B **426**, 19-52 (1994) [erratum: Nucl. Phys. B **430**, 485-486 (1994)] doi:10.1016/0550-3213(94)90124-4 [arXiv:hep-th/9407087 [hep-th]].
- [4] N. Seiberg and E. Witten, “Monopoles, duality and chiral symmetry breaking in N=2 supersymmetric QCD,” Nucl. Phys. B **431**, 484-550 (1994) doi:10.1016/0550-3213(94)90214-3 [arXiv:hep-th/9408099 [hep-th]].
- [5] P. C. Argyres and M. R. Douglas, “New phenomena in SU(3) supersymmetric gauge theory,” Nucl. Phys. B **448**, 93-126 (1995) doi:10.1016/0550-3213(95)00281-V [arXiv:hep-th/9505062 [hep-th]].
- [6] P. C. Argyres, M. R. Plesser, N. Seiberg and E. Witten, “New N=2 superconformal field theories in four-dimensions,” Nucl. Phys. B **461**, 71-84 (1996) doi:10.1016/0550-3213(95)00671-0 [arXiv:hep-th/9511154 [hep-th]].
- [7] T. Eguchi, K. Hori, K. Ito and S. K. Yang, “Study of N=2 superconformal field theories in four-dimensions,” Nucl. Phys. B **471**, 430-444 (1996) doi:10.1016/0550-3213(96)00188-5 [arXiv:hep-th/9603002 [hep-th]].
- [8] K. Ito, “A-D-E singularity and the Seiberg-Witten theory,” Prog. Theor. Phys. Suppl. **135**, 94-108 (1999) doi:10.1143/PTPS.135.94 [arXiv:hep-th/9906023 [hep-th]].
- [9] D. Gaiotto, N. Seiberg and Y. Tachikawa, “Comments on scaling limits of 4d N=2 theories,” JHEP **01**, 078 (2011) doi:10.1007/JHEP01(2011)078 [arXiv:1011.4568 [hep-th]].

- [10] K. Maruyoshi and J. Song, “Enhancement of Supersymmetry via Renormalization Group Flow and the Superconformal Index,” *Phys. Rev. Lett.* **118**, no.15, 151602 (2017) doi:10.1103/PhysRevLett.118.151602 [arXiv:1606.05632 [hep-th]].
- [11] J. M. Maldacena, “The Large N limit of superconformal field theories and supergravity,” *Int. J. Theor. Phys.* **38**, 1113-1133 (1999) doi:10.1023/A:1026654312961 [arXiv:hep-th/9711200 [hep-th]].
- [12] E. Witten, “Bound states of strings and p-branes,” *Nucl. Phys. B* **460**, 335-350 (1996) doi:10.1016/0550-3213(95)00610-9 [arXiv:hep-th/9510135 [hep-th]].
- [13] G. T. Horowitz and A. Strominger, “Black strings and P-branes,” *Nucl. Phys. B* **360**, 197-209 (1991) doi:10.1016/0550-3213(91)90440-9
- [14] T. Sakai and S. Sugimoto, “Low energy hadron physics in holographic QCD,” *Prog. Theor. Phys.* **113**, 843-882 (2005) doi:10.1143/PTP.113.843 [arXiv:hep-th/0412141 [hep-th]].
- [15] T. Sakai and S. Sugimoto, “More on a holographic dual of QCD,” *Prog. Theor. Phys.* **114**, 1083-1118 (2005) doi:10.1143/PTP.114.1083 [arXiv:hep-th/0507073 [hep-th]].
- [16] J. Kinney, J. M. Maldacena, S. Minwalla and S. Raju, “An Index for 4 dimensional super conformal theories,” *Commun. Math. Phys.* **275**, 209-254 (2007) doi:10.1007/s00220-007-0258-7 [arXiv:hep-th/0510251 [hep-th]].
- [17] J. McGreevy, L. Susskind and N. Toumbas, “Invasion of the giant gravitons from Anti-de Sitter space,” *JHEP* **06**, 008 (2000) doi:10.1088/1126-6708/2000/06/008 [arXiv:hep-th/0003075 [hep-th]].
- [18] I. Garc’ia-Etxebarria and D. Regalado, “ $\mathcal{N} = 3$  four dimensional field theories,” *JHEP* **03**, 083 (2016) doi:10.1007/JHEP03(2016)083 [arXiv:1512.06434 [hep-th]].
- [19] Y. Imamura and S. Yokoyama, “Superconformal index of  $\mathcal{N} = 3$  orientifold theories,” *J. Phys. A* **49**, no.43, 435401 (2016) doi:10.1088/1751-8113/49/43/435401 [arXiv:1603.00851 [hep-th]].
- [20] O. Aharony and Y. Tachikawa, “S-folds and 4d  $N=3$  superconformal field theories,” *JHEP* **06**, 044 (2016) doi:10.1007/JHEP06(2016)044 [arXiv:1602.08638 [hep-th]].
- [21] G. Zafrir, “An  $\mathcal{N} = 1$  Lagrangian for an  $\mathcal{N} = 3$  SCFT,” *JHEP* **01**, 062 (2021) doi:10.1007/JHEP01(2021)062 [arXiv:2007.14955 [hep-th]].
- [22] R. Arai and Y. Imamura, “Finite  $N$  Corrections to the Superconformal Index of S-fold Theories,” *PTEP* **2019**, no.8, 083B04 (2019) doi:10.1093/ptep/ptz088

- 
- [arXiv:1904.09776 [hep-th]].
- [23] R. Arai, S. Fujiwara and Y. Imamura, “BPS Partition Functions for S-folds,” *JHEP* **03**, 172 (2019) doi:10.1007/JHEP03(2019)172 [arXiv:1901.00023 [hep-th]].
- [24] E. Witten, “Constraints on Supersymmetry Breaking,” *Nucl. Phys. B* **202**, 253 (1982) doi:10.1016/0550-3213(82)90071-2
- [25] V. Pestun, “Localization of gauge theory on a four-sphere and supersymmetric Wilson loops,” *Commun. Math. Phys.* **313**, 71-129 (2012) doi:10.1007/s00220-012-1485-0 [arXiv:0712.2824 [hep-th]].
- [26] G. Mack and A. Salam, “Finite component field representations of the conformal group,” *Annals Phys.* **53**, 174-202 (1969) doi:10.1016/0003-4916(69)90278-4
- [27] D. A. Kastor, E. J. Martinec and S. H. Shenker, “RG Flow in N=1 Discrete Series,” *Nucl. Phys. B* **316**, 590-608 (1989) doi:10.1016/0550-3213(89)90060-6
- [28] F. Cachazo, M. R. Douglas, N. Seiberg and E. Witten, “Chiral rings and anomalies in supersymmetric gauge theory,” *JHEP* **12**, 071 (2002) doi:10.1088/1126-6708/2002/12/071 [arXiv:hep-th/0211170 [hep-th]].
- [29] I. Biswas, D. Gaiotto, S. Lahiri and S. Minwalla, “Supersymmetric states of N=4 Yang-Mills from giant gravitons,” *JHEP* **12**, 006 (2007) doi:10.1088/1126-6708/2007/12/006 [arXiv:hep-th/0606087 [hep-th]].
- [30] S. Benvenuti, B. Feng, A. Hanany and Y. H. He, “Counting BPS Operators in Gauge Theories: Quivers, Syzygies and Plethystics,” *JHEP* **11**, 050 (2007) doi:10.1088/1126-6708/2007/11/050 [arXiv:hep-th/0608050 [hep-th]].
- [31] J. Polchinski, “Dirichlet Branes and Ramond-Ramond charges,” *Phys. Rev. Lett.* **75**, 4724-4727 (1995) doi:10.1103/PhysRevLett.75.4724 [arXiv:hep-th/9510017 [hep-th]].
- [32] J. Polchinski, S. Chaudhuri and C. V. Johnson, “Notes on D-branes,” [arXiv:hep-th/9602052 [hep-th]].
- [33] E. Witten, “Anti-de Sitter space and holography,” *Adv. Theor. Math. Phys.* **2**, 253-291 (1998) doi:10.4310/ATMP.1998.v2.n2.a2 [arXiv:hep-th/9802150 [hep-th]].
- [34] M. Gunaydin and N. Marcus, “The Spectrum of the  $s^{*5}$  Compactification of the Chiral N=2, D=10 Supergravity and the Unitary Supermultiplets of  $U(2, 2/4)$ ,” *Class. Quant. Grav.* **2**, L11 (1985) doi:10.1088/0264-9381/2/2/001
- [35] Y. Y. Goldschmidt, “ $1/N$  Expansion in Two-dimensional Lattice Gauge Theory,” *J. Math. Phys.* **21**, 1842 (1980) doi:10.1063/1.524600

- [36] A. Mikhailov, “Giant gravitons from holomorphic surfaces,” *JHEP* **11**, 027 (2000) doi:10.1088/1126-6708/2000/11/027 [arXiv:hep-th/0010206 [hep-th]].
- [37] A. Echeverria-Enriquez, M. C. Munoz-Lecanda, N. Roman-Roy and C. Victoria-Monge, “Mathematical foundations of geometric quantization,” *Extracta Math.* **13**, 135-238 (1998) [arXiv:math-ph/9904008 [math-ph]].
- [38] O. Aharony and M. Evtikhiev, “On four dimensional  $N = 3$  superconformal theories,” *JHEP* **04**, 040 (2016) doi:10.1007/JHEP04(2016)040 [arXiv:1512.03524 [hep-th]].
- [39] E. Witten, “Baryons and branes in anti-de Sitter space,” *JHEP* **07**, 006 (1998) doi:10.1088/1126-6708/1998/07/006 [arXiv:hep-th/9805112 [hep-th]].
- [40] P. Goddard, J. Nuyts and D. I. Olive, “Gauge Theories and Magnetic Charge,” *Nucl. Phys. B* **125**, 1-28 (1977) doi:10.1016/0550-3213(77)90221-8
- [41] J. H. Schwarz, “Covariant Field Equations of Chiral  $N=2$   $D=10$  Supergravity,” *Nucl. Phys. B* **226**, 269 (1983) doi:10.1016/0550-3213(83)90192-X
- [42] J. H. Schwarz and P. C. West, “Symmetries and Transformations of Chiral  $N=2$   $D=10$  Supergravity,” *Phys. Lett. B* **126**, 301-304 (1983) doi:10.1016/0370-2693(83)90168-5
- [43] S. Benvenuti and S. Giacomelli, “Supersymmetric gauge theories with decoupled operators and chiral ring stability,” *Phys. Rev. Lett.* **119**, no.25, 251601 (2017) doi:10.1103/PhysRevLett.119.251601 [arXiv:1706.02225 [hep-th]].
- [44] F. A. Dolan and H. Osborn, “Applications of the Superconformal Index for Protected Operators and  $q$ -Hypergeometric Identities to  $N=1$  Dual Theories,” *Nucl. Phys. B* **818**, 137-178 (2009) doi:10.1016/j.nuclphysb.2009.01.028 [arXiv:0801.4947 [hep-th]].
- [45] L. Rastelli and S. S. Razamat, “The supersymmetric index in four dimensions,” *J. Phys. A* **50**, no.44, 443013 (2017) doi:10.1088/1751-8121/aa76a6 [arXiv:1608.02965 [hep-th]].
- [46] A. Gadde, L. Rastelli, S. S. Razamat and W. Yan, “Gauge Theories and Macdonald Polynomials,” *Commun. Math. Phys.* **319**, 147-193 (2013) doi:10.1007/s00220-012-1607-8 [arXiv:1110.3740 [hep-th]].
- [47] R. Arai, S. Fujiwara, Y. Imamura and T. Mori, “Schur index of the  $\mathcal{N} = 4$   $U(N)$  supersymmetric Yang-Mills theory via the AdS/CFT correspondence,” *Phys. Rev. D* **101**, no.8, 086017 (2020) doi:10.1103/PhysRevD.101.086017 [arXiv:2001.11667 [hep-th]].
- [48] R. Arai, S. Fujiwara, Y. Imamura and T. Mori, “Finite  $N$  corrections to the

- 
- superconformal index of orbifold quiver gauge theories,” JHEP **10**, 243 (2019) doi:10.1007/JHEP10(2019)243 [arXiv:1907.05660 [hep-th]].
- [49] R. Arai, S. Fujiwara, Y. Imamura and T. Mori, “Finite  $N$  corrections to the superconformal index of toric quiver gauge theories,” PTEP **2020**, no.4, 043B09 (2020) doi:10.1093/ptep/ptaa023 [arXiv:1911.10794 [hep-th]].
- [50] R. Arai, S. Fujiwara, Y. Imamura, T. Mori and D. Yokoyama, “Finite- $N$  corrections to the M-brane indices,” JHEP **11**, 093 (2020) doi:10.1007/JHEP11(2020)093 [arXiv:2007.05213 [hep-th]].
- [51] S. Kachru and E. Silverstein, “4-D conformal theories and strings on orbifolds,” Phys. Rev. Lett. **80**, 4855-4858 (1998) doi:10.1103/PhysRevLett.80.4855 [arXiv:hep-th/9802183 [hep-th]].
- [52] A. E. Lawrence, N. Nekrasov and C. Vafa, “On conformal field theories in four-dimensions,” Nucl. Phys. B **533**, 199-209 (1998) doi:10.1016/S0550-3213(98)00495-7 [arXiv:hep-th/9803015 [hep-th]].
- [53] B. Feng, A. Hanany and Y. H. He, “D-brane gauge theories from toric singularities and toric duality,” Nucl. Phys. B **595**, 165-200 (2001) doi:10.1016/S0550-3213(00)00699-4 [arXiv:hep-th/0003085 [hep-th]].
- [54] B. Feng, S. Franco, A. Hanany and Y. H. He, “Symmetries of toric duality,” JHEP **12**, 076 (2002) doi:10.1088/1126-6708/2002/12/076 [arXiv:hep-th/0205144 [hep-th]].
- [55] I. R. Klebanov and E. Witten, “Superconformal field theory on three-branes at a Calabi-Yau singularity,” Nucl. Phys. B **536**, 199-218 (1998) doi:10.1016/S0550-3213(98)00654-3 [arXiv:hep-th/9807080 [hep-th]].
- [56] O. Aharony, O. Bergman, D. L. Jafferis and J. Maldacena, “ $N=6$  superconformal Chern-Simons-matter theories, M2-branes and their gravity duals,” JHEP **10**, 091 (2008) doi:10.1088/1126-6708/2008/10/091 [arXiv:0806.1218 [hep-th]].
- [57] C. Beem, M. Lemos, P. Liendo, W. Peelaers, L. Rastelli and B. C. van Rees, “Infinite Chiral Symmetry in Four Dimensions,” Commun. Math. Phys. **336**, no.3, 1359-1433 (2015) doi:10.1007/s00220-014-2272-x [arXiv:1312.5344 [hep-th]].
- [58] T. Nishinaka and Y. Tachikawa, “On 4d rank-one  $\mathcal{N} = 3$  superconformal field theories,” JHEP **09**, 116 (2016) doi:10.1007/JHEP09(2016)116 [arXiv:1602.01503 [hep-th]].
- [59] O. Aharony, A. Fayyazuddin and J. M. Maldacena, “The Large  $N$  limit of  $N=2$ ,  $N=1$  field theories from three-branes in F theory,” JHEP **07**, 013 (1998) doi:10.1088/1126-

- 6708/1998/07/013 [arXiv:hep-th/9806159 [hep-th]].
- [60] A. Fayyazuddin and M. Spalinski, “Large N superconformal gauge theories and supergravity orientifolds,” *Nucl. Phys. B* **535**, 219-232 (1998) doi:10.1016/S0550-3213(98)00545-8 [arXiv:hep-th/9805096 [hep-th]].
- [61] D. Gaiotto, “N=2 dualities,” *JHEP* **08**, 034 (2012) doi:10.1007/JHEP08(2012)034 [arXiv:0904.2715 [hep-th]].
- [62] D. Gaiotto and J. Maldacena, “The Gravity duals of N=2 superconformal field theories,” *JHEP* **10**, 189 (2012) doi:10.1007/JHEP10(2012)189 [arXiv:0904.4466 [hep-th]].
- [63] S. P. Martin, “A Supersymmetry primer,” *Adv. Ser. Direct. High Energy Phys.* **21**, 1-153 (2010) doi:10.1142/9789812839657\_0001 [arXiv:hep-ph/9709356 [hep-ph]].