

論文 / 著書情報
Article / Book Information

Title	SkyScraper-I: Tethered Whole Windows Cleaning Robot-Design of Moving Mechanisms and Preliminary Experiments-
Author	SHIGEO HIROSE, Se-gon Roh, Noriaki Imaoka, Yusuke Nishida
Journal/Book name	IEEE/RSJ International Conference on Intelligent Robots and Systems, IROS, , ,
発行日 / Issue date	2010, 10
権利情報 / Copyright	(c)2010 IEEE. Personal use of this material is permitted. However, permission to reprint/republish this material for advertising or promotional purposes or for creating new collective works for resale or redistribution to servers or lists, or to reuse any copyrighted component of this work in other works must be obtained from the IEEE.

SkyScraper-I: Tethered Whole Windows Cleaning Robot

-Design of Moving Mechanisms and Preliminary Experiments-

Noriaki Imaoka, Se-gon Roh, Nishida Yusuke, and Shigeo Hirose*

Abstract— Many serious accidents are reported about the manual window cleaning task, and it is needed to automate the task for the majority of windows having no special guide frames for window cleaning machines. This paper proposes a novel tethered window cleaning robot named a “SkyScraper-I” and discusses its design. The SkyScraper-I has the functions to approach all the windows located on one side of a building by controlling the lengths of a pair of suspending tethers from the top of the building and to clean the whole surface of the windows. The robot consists of the vertically suspended sliding rod, a pair of clamping arms with clamping suction rollers on both ends, and a squeegee sliding mechanism to wipe the window. The clamping suction rollers have three functions: to fix the SkyScraper between the upper and lower frames of the window, to produce a suction force without touching the window, and to drive sideways for wiping all the window. From the several preliminary experiments, the SkyScraper-I demonstrated good mobility to move from window to window and to clean the surface of each window.

I. INTRODUCTION

Since the manual window cleaning task of buildings is very dangerous, introduction of automated window cleaning robots is strongly demanded; although some of the modern buildings often install special guide frames for window cleaning machine [1], the majority of buildings are not equipped with such guide frames.

Generally the window cleaning robot needs two types of mobility to realize the window cleaning task: “Mobility A” to move among the windows and “Mobility B” to drive a window cleaning squeegee on the surface of the window; in this paper, we call the robot with these two types of mobility the “whole windows cleaning robot”.

Until now, several types of window cleaning robots with special mobility have been proposed. Most of them have been focused on the Mobility B. Based on the suction capability of vacuum suckers, they have the driving wheels to make continuous moving motion on the window [2], or have the leg type mechanisms to make a discrete walking motion on the window [3], [4]. However, it is difficult to clean all surface of the window from one edge to the other edge of the window although they demonstrated the interesting wall-climbing motions on the windows.

Meanwhile, some robots have been developed considering the Mobility A. For example, the WindHopper [5] is sus-

ended by a pair of tethers and it can make a jumping motion to move from one window to another. Its posture is balanced by the control of the lengths of a pair of tethers while jumping by using four legs. For another example, a hovering robot with Mobility A by using a tether suspension and air thrusters has also been proposed [6].



Fig. 1. Whole Windows Cleaning Robot “SkyScraper-I”.

Likewise, existing window cleaning robots generally have Mobility A or Mobility B. However, few of them with these two kinds of mobility have been reported.

In this study, we propose a new concept of a window cleaning robot named a “SkyScraper-I” having both Mobility A and Mobility B (see Fig. 1). Based on this approach, the design of the mechanism of the SkyScraper-I is introduced and discussed. Then, its feasibility and effectiveness are demonstrated through the driving experiments and finally conclusions are followed.

II. PROPOSED DESIGN CONCEPT

A. Window-to-Window Locomotion (Mobility A)

For the window-to-window locomotion of the SkyScraper, we adopted the same method used for our former model WindHopper [5]. In the real operation, reels are installed on the top of the building and they make it possible to cover all windows of a building with ease. When having designed the WindHopper, we used a jumping motion in order to produce the separating and approaching motions from one window to another. Though it is possible to move among the windows

The authors are with Department of Mechanical and Aerospace Engineering, Tokyo Institute of Technology, 2-12-1 O-okayama, Meguro-ku, Tokyo, 152-8552, Japan.

* Corresponding Author, E-mail: hirose@mes.titech.ac.jp.

fast by using this method, there is possibility that the suspending tethers come in contact with the obstacles of a window such as windowsills, as shown in Fig. 2 when the robot cleans the window (Dynamic Type). For this reason, we introduce a static arm thrusting method (Static Type). In this new method, only when the robot cleans the window, the window cleaning mechanism is thrust to the window by driving the arm. Thus, the tethers can be separated from the obstacles at all the time.

	Dynamic Type	Static Type
Cleaning		
Tethered Driving		

Fig. 2. Comparison of the Tethered Driving on the Wall.

B. Locomotion for Cleaning of the Whole Surface of a Window (Mobility B)

To realize cleaning of the whole surface of a window, the authors noticed cleaning methods. The well-known window cleaning method is to use a rotating disk. It seems to be useful considering the fast cleaning speed but it cannot be enough to clean all the surfaces of the window; the edge areas of the window still remain unclean. To overcome this problem, we tried to find a way and finally concluded that the method using a squeegee would be very effective.

A squeegee that is a rubber spatula is widely used by the window cleaning human workers. The worker who is suspended by tethers approaches the window and paints a liquid detergent on the window, and then skillfully wipes the surface of the window by using the squeegee. This simple motion to wipe off the detergent makes the window very clean. The squeegee can also be closely approached to the edge areas of the window and thus suitable to clean the window surface entirely.

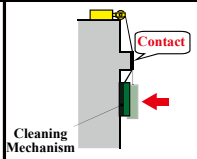
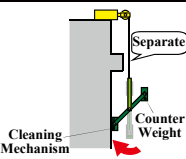
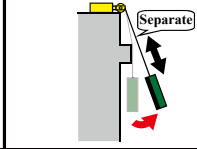
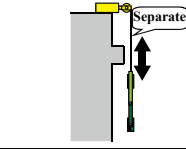
The authors developed the squeegee of 265 mm in widths as shown in Fig. 3 and did simple window cleaning experiment to measure the required force and the contact angle for cleaning the window. Changing the approach angle between the squeegee and the window surface as 90° , 60° , and 45° , we measured the required pushing force to wipe out and to clean the detergent, which had been painted on the window surface, by using the force sensor between the squeegee and the hand. Fig. 4 shows the wiped state of the window surface by the forces 3.2 N and 5.5 N when the angle θ between the squeegee and the window surface is 60° . The values of the force F and the angle θ are somewhat difficult to be generalized because they are influenced by the material, surface

hardness, flexibility, thickness, contact edge's sharpness, etc. of the squeegee. According to various tests, we chose the values. This preliminary test shows that the cleaning method by the squeegee can be applicable with comparatively small supporting forces.

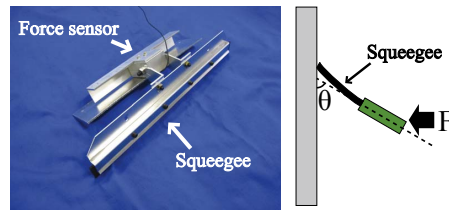

Fig. 3. Configuration of a Squeegee.

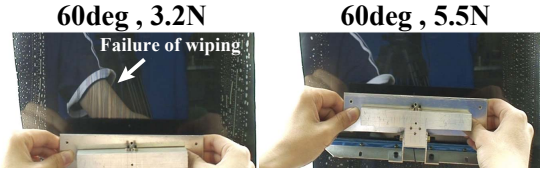

Fig. 4. Experiment of Window Cleaning Using the Squeegee.

Fig. 5 illustrate how to drive the squeegee on the window. Conventional method in Fig. 5 is that the robot with the squeegee attached around its body moves around the surface of the window. Under this method, it is noted that the trace by a sucker cannot be wiped and remain on the window when the robot is final position and the robot is going to leave the window. For this reason, we proposed a new method to clean the window without remaining the trace.

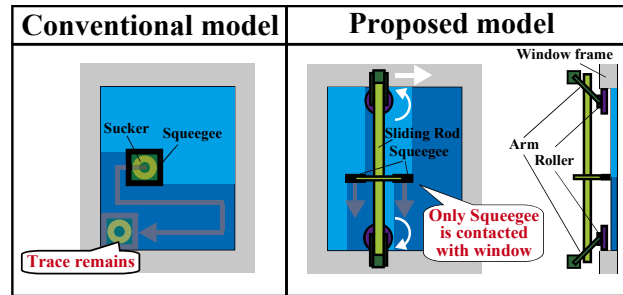

Fig. 5. Comparison of the driving squeegee on the window.

Generally, there are window frames around the windows to protect and support glass. Therefore, we focused the specific motion that uses these frames as the guides of the robot, as illustrated in Fig. 5. The driving method called a WFC (Window Frames Clamping) driving is to clamp the frames of the top and bottom of the window by giving a slope to two arms and gripping two rollers on the ends of the arms without contacting with the surface of the window. After the rollers are clamped between the frames, the squeegees are thrust to the window and driven along a vertical sliding rod to wipe the window. After the wiping, the squeegees are removed, the upper and lower rollers are simultaneously rotated to drive the sliding rod sideways, and then the squeegees make the wiping motion again. By using the WFC drive, all the surface of the window can be wiped very effectively. Furthermore, the position control of this method is easy because it needs only to move along the guide.

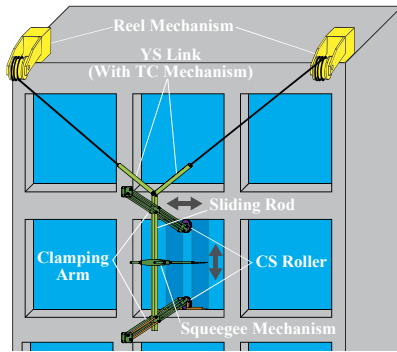

Fig. 6. Proposed Method to drive the squeegee on the window.

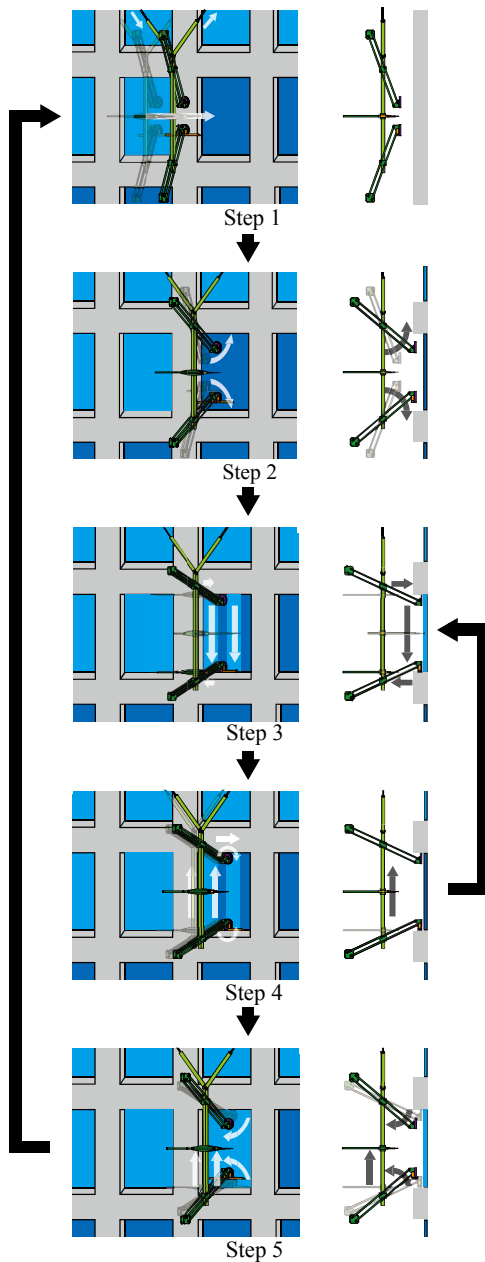

Fig. 7. Steps of Window Cleaning. Step 1: Window-to-window Movement by Tethered-driving. Step 2: Clamping of Rollers between the Frames. Step 3: Cleaning of the window. Step 4: Sideway Driving on the Window. Step 5: Unclamping of the Rollers.

C. Whole Windows Cleaning Robot “SkyScraper-I”

Then we propose the novel window cleaning robot named SkyScraper-I, as shown in Fig.6, which have both Mobility A by using tethered driving and Mobility B by using WFC driving. SkyScraper-I can realize whole windows cleaning and be compensated its own weight by tether at all time.

The steps of cleaning of the window by the SkyScraper-I are shown in Fig. 7 and the sequences are as follows:

- Step 1: Window-to-window motion by the length control of a pair of tethers,
- Step 2: Clamping of the CS rollers between the frames by the control of the inclination angle of the clamping arms and by the synchronized control of the length of the tethers,
- Step 3: Cleaning of the window by the sliding motion of the squeegee mechanism from the top to bottom of the window surface
- Step 4: Driving the SkyScraper-I sideways toward a new cleaning position while the squeegees return to the top position by rolling of the CS rollers and by the synchronized control of the length of the tethers
- Step 5: Unclamping of the CS rollers and moving to the next window and returning to Step 1.

III. IMPLEMENTATION

We developed the prototype of SkyScraper-I. This robot consists of 1) the CS rollers clamped between the frames that drive the SkyScraper-I sideways without contacting with the window surface, 2) the clamping arm to clamp the CS rollers between the frames, 3) a pair of the reel mechanisms to control the length of the tethers, 4) the YS (Yaw Stabilization) link to stabilize the posture of the SkyScraper-I, and 5) the TC (Tether Compliance) mechanism used for the adaptive control of the lengths of the tethers to follow the motion of SkyScraper-I. In this section, these mechanisms are explained.

A. CS Roller (Cramping and Suction Roller)

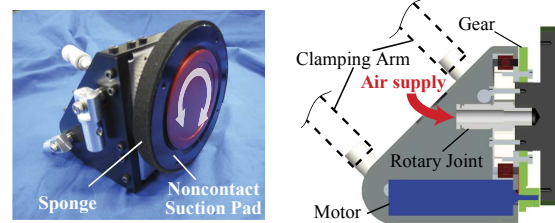

Fig. 8. Structure of the CS Roller.

The basic function of the CS roller is an active wheel to move on the widow-frames. In addition, it acts as a clamping device to grip the frame easily because it is a disc-shape gripper covered with sponge.

For the successful WFC driving, the proposed CS roller has a noncontact suction pad, which is an additional mechanism to support the effective clamp between the window frames, as shown in Fig. 8. Usefulness of the CS roller is that its suction pad is kept very close to the window. This suction

pad has no contact with the window and thus leaves no trace on the window, because it is floated by supplying of the compressed air. This suction pad does not produce the suction force sucked by the generated vacuum. On the contrary, it supplies the compressed air and causes the fast flow of the air between the window and the suction pad in order to make the gap in low pressure, as the Bernoulli's theory explains. For supplying air, a rotary joint is embedded into the CS roller. The sucking force of the noncontact suction pad is 39.2 N when the compressed air of 0.5 MPa is supplied. Since this force is much larger than the force (about 5N) required for cleaning by the squeegee, the CS roller is verified to be very effective.

B. Clamping Arm

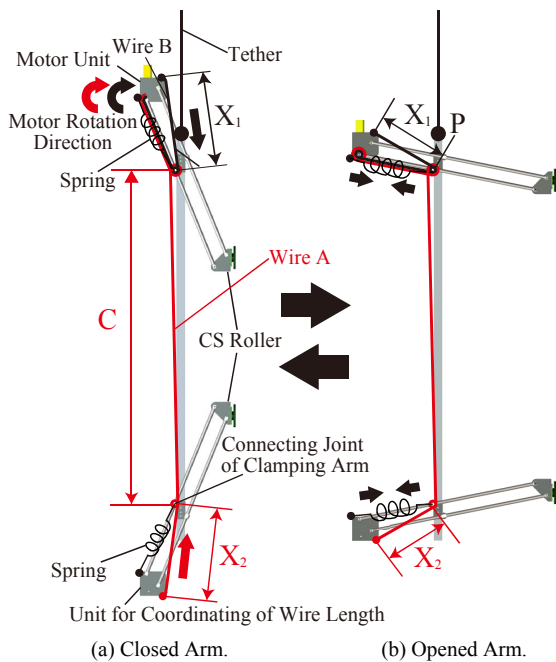

Fig. 9. Clamping Arm Mechanism.

When the CS rollers are approaching the surface of the window, both the upper and lower CS rollers should be maintained to be parallel to the surface of the window. For this reason, parallel link mechanism is installed in the upper and lower clamping arms, as shown in Fig. 9. At the same time, in order to keep the same distance between two CS rollers and the window surface, the upper and lower clamping arms are driven at the same angle by the wire-driving mechanism. Two wires of this mechanism are stretched between the diagonal joints of the parallel mechanism. When the clamping arms are folded or unfolded, both the wire A to change the length X_1 and the wire B to change the length X_2 as shown in Fig. 9(a) are driven by the same reel in order for the lengths of the wires to be changed at the same rate. Since the worm-gear motor that is not back drivable drives the reel as shown in Fig. 10(a), the clamping arms maintain the clamping motion even when the driving power supply is

stopped. The clamping arm is being opened and unfolded as shown in Fig. 9 (b) when the motor drives. On the other hand, the clamping Arm is being closed and folded as shown in Fig. 9(a) when the spring force is applied.

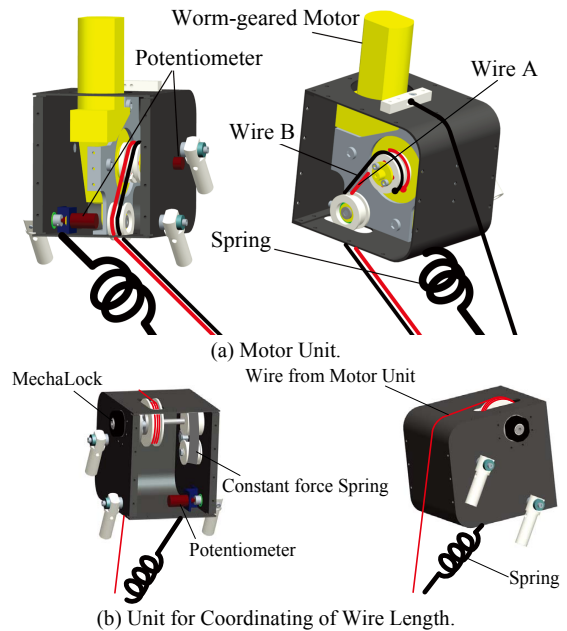

Fig. 10. Clamping Arm Units.

Since the height of the window differs from building to building, the mechanism to adjust the distance between clamping arms is needed. For implementation of this, we designed the connecting joints of the clamping arms, which are sliding and locked along the sliding rod before the robot starts the cleaning task. In addition, a unit for coordinating of the wire length was designed, as shown in Figs. 9(a) and 10(b). This unit consists of a reel fixing the end of wire A, a torque generator by the constant force spring, and a locking and releasing mechanism by a mechalock. Owing to this unit, the wire length C in Fig. 9(a) can be changed when the distance between the clamping arms is adjusted to the size of the window only by releasing the mechalock and making the wired pulley free to rotate. When the distance C is set, the mechalock is locked in order to make the end of the wire fixed.

C. YS Link (Yaw Stabilization Link)

The function to maintain the vertical posture of the sliding rod is important to clamp the window frame properly and drive the squeegee in good posture. We can think of an active posture balancing system such as a system with multiple air thrusters based on their coordination control. However, to control the system is difficult and the system takes lots of energy. In this sense, the SkyScraper-I maintains its posture by using simple and effective method. In other words, it keeps stable posture by suspending its weight at the high position P while the center of gravity is very low due to its long body (see Fig. 11). From this suspension method, the postures

around the roll axis and the pitch axis can be stabilized. However, this method is not enough to generate the stability around the yaw axis as shown in Fig. 11A. To overcome this problem, we have a pair of the YS link attached to the joint on the position P and make the links rotatable around the pitch axis at P as shown in Fig. 12B; the tether is connected to the other side of the YS links. This suspending method using the YS Link can generate the large recovery moment around the yaw axis due to the effect of the traction forces F_1 and F_2 of the tethers when the SkyScraper-I rotates around the yaw axis. Consequently, the roll, pitch, and yaw postures of the SkyScraper-I are mechanically stabilized. Moreover, owing to the introduction of the counter weight to the clamping arm, the SkyScraper-I can maintain the stable posture of the in any angle when the arms clamp the window frames.

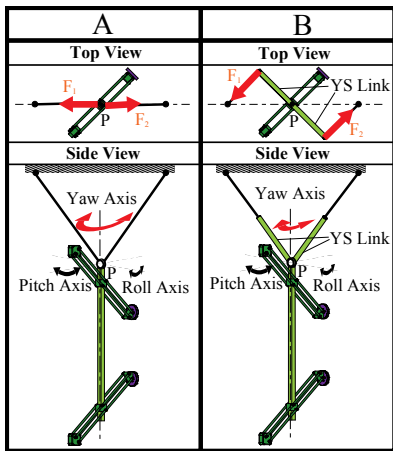

Fig. 11. YS Link.

D. TC Mechanism (Tether Compliance Mechanism)

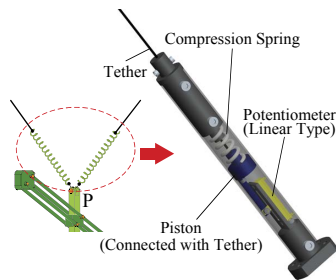
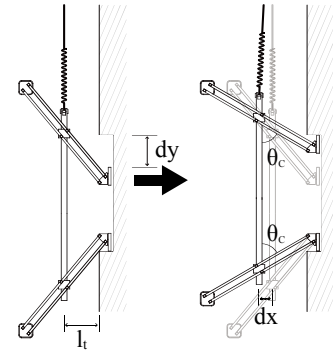

Fig. 12. TC Mechanism.

In the working process step 2 or step 4 in Fig. 7, the lengths of a pair of tethers are related to the motions of the CS rollers and the clamping arms. If the adjustment of the lengths of tethers are not correct, then internal force on the CS roller will be generated and the SkyScraper-I will be separated from the surface of the window. To avoid this kind of accident, we introduced the TC mechanism to make the length of tethers adjustable as shown in Fig. 12. It is installed inside the YS link and composed of a spring and a potentiometer to measure the length of the spring. By measuring the length of the spring, the traction force of the tether can be calculated. Since both length and force of the tether are controlled, the clamping arms with the CS roller can easily follow the frame of the

window. For these control, we constructed a simple control architecture. In other words, the lengths of tethers are controlled in order to drive the SkyScraper-I to the direction of the traction force except the self-weight of the robot.



(a) Approach for clamping. (b) Adjustment for Clamping.

Fig. 13. Model of Clamping Window Frames.

For example, let us assume that the process of step 2 in Fig. 7. As shown in Fig. 13(a), when the SkyScraper-I is not correctly located on the window in order to clamp the window frames, there exists the gap dy while the clamping arm is being opened. At this stage, the lower clamping arm pushes the window frame, and then the traction force of the tethers will decrease. Since the decreased force is measured by the TC mechanism, the length of the tethers are controlled to be shorter. Consequently, both the upper and lower clamping arms have contact with the frames with the angle θ_c and the distance (l_t+dx) between the window and the sliding rod, as shown in Fig. 13(b).

IV. PRELIMINARY EXPERIMENTS OF “SKYSCRAPER-I”

The experiment to evaluate the proposed window-to-window motion was done by controlling the length of the tethers, as shown in Fig. 14. The SkyScraper-I could realize the motion for 14 sec on average.

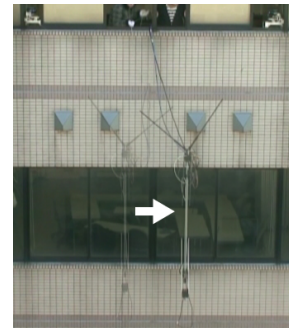

Fig. 14. Experiment of Moving Window-to-Window.

Fig. 15 shows the experiment of clamping window frames. The steps are as follows: (1) the clamping arms are opened, (2) the CS roller starts touching the surface of the window, (3) while the clamping arms keeps being opened, the lower CS roller touches the window frame, (4) the tethers are slightly pulled and both of the clamping arms have contact with the window frames. In this experiment, the SkyScraper-I suc-

cessfully achieved to clamp the window frames without having contact with the surface of the window.

Fig. 16 shows the experiment to verify the sideway drive motion of the SkyScraper-I on the window frames. Although a speed control command is send to the robot so that the upper and lower CS rollers can have the same rotational speed, the rotational speeds ω_u and ω_l cannot be always same. In this case, since the robot cannot maintain a vertical posture and can be inclined with the angle θ_a , as shown in Fig.17, it uses a posture sensor for adjusting the rotational speed of the CS rollers.

From these experiments, we could confirm that the SkyScraper-I has the ability to move from window to window and to drive the vertical sliding rod from one side to another of each window in order to clean the whole surface of the window.

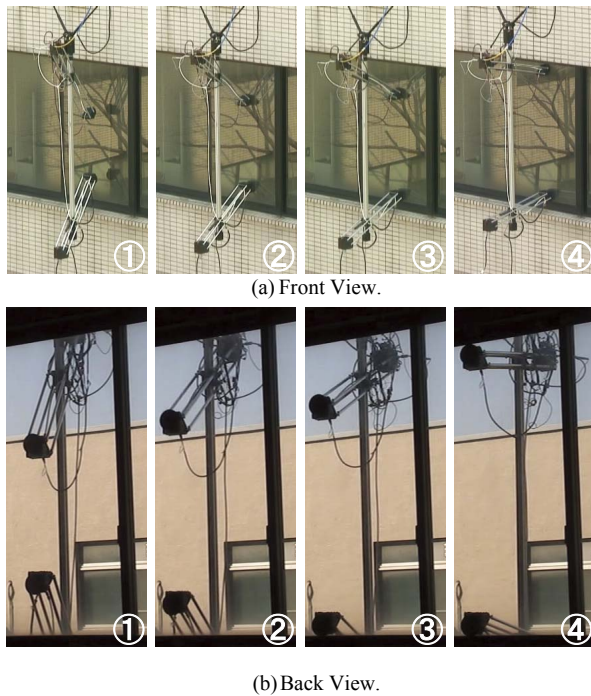

Fig. 15. Experiment of Clamping Window Frames.

V. CONCLUSIONS AND FUTURE WORKS

In this paper, we proposed the concept of the whole windows cleaning robot “SkyScraper-I”, which can approach all the window of one side of the building by the control of a pair of tethers. The proposed robot can carry the squeegee all over the window by using the frames of the windows without having contact with the window.

It is successful to realize the mobility part of the SkyScraper-I, but the cleaning mechanism of the SkyScraper-I was not discussed in the paper. We already study on the specific squeegee driving mechanism for the SkyScraper-I, which moves along the vertical sliding rod. It consists of an automatic detergent supplying and disposing mechanism. We are going to report about them in the next paper.

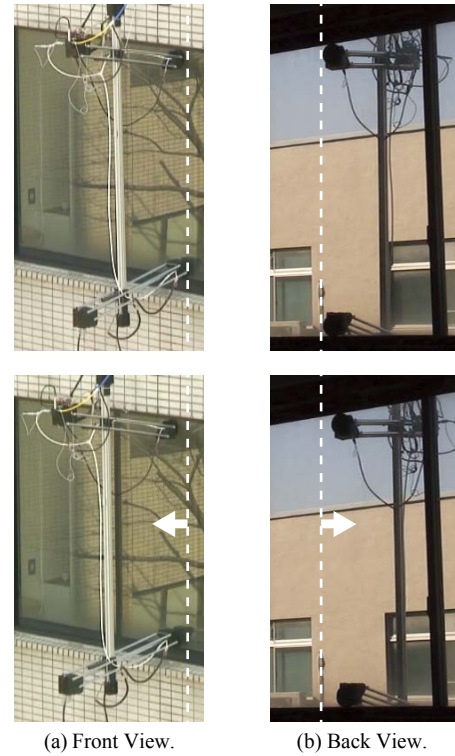

Fig. 16. Experiment of the Sideway Drive.

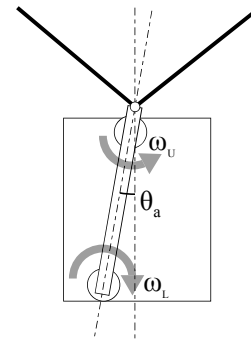

Fig. 17. Model of Clamping for the Sideway Drive.

REFERENCES

- [1] Teruo Yokota, Yoshihiro Nishiyama and Tadao Takasaki, “Horizontally Moving Automatic Outer Surface Cleaning,” *U.S. Patent* 4 809 384, Mar 16, 1989.
- [2] Tohru Miyake and Hidenori Ishihara, “Mechanisms and Basic Properties of Window Cleaning Robot,” in *Proc. International Conference on Advanced Intelligent Mechatronics*, 2003, pp. 1372-1377.
- [3] Houxiang Zhang, Jianwei Zhang and Guanghua Zong, “Requirements of Glass Cleaning and development of Climbing Robot Systems,” in *Proc. Intelligent Mechatronics and Automation*, pp. 101-106, 2004.
- [4] Zhi-yuan Qian, Yan-zheng Zhao and Zhuang Fu, “Development of Wall-climbing Robots with Sliding Suction Cups,” in *Proc. Int. Conf. Intelligent Robots and Systems*, pp. 3417-3422, 2006.
- [5] Takahiro Tanaka, Noriaki Imaoka, Kichinosuke Hirokawa and Shigeo Hirose, “Development of Jumping Robot for Wall-surface Operation (1stReport, Concept Proposal and Basic Experiment),” *J. Japan Society for Design Engineering*, vol. 44, no. 4, pp. 58-66, 2009 (in Japanese).
- [6] Atsushi Ono, Toshio Takayama and Toru Omata, “Hovering and contacting mobile robot for manipulation on wall,” in *Proc. JSME Conf. Robotics and Mechatronics*, 2P1-108, 2007 (in Japanese).