

論文 / 著書情報  
Article / Book Information

Title(English)	Effects of deuterium density on the surface of the cathode on NPR
Authors(English)	Keita Nobe, Hiroki Imaji, Kazuki Nanjo, Wantapon Ngamdee, Masato Watanabe, Eiki Hotta
Citation(English)	14th US-Japan Workshop on Inertial Electrostatic Confinement, S4P2
Pub. date	2012, 10

IEC Workshop 2012

# Effects of cathode temperature on neutron production rate in inertial electrostatic confinement fusion

Keita Nobe\*, Hiroki Imaji, Kazuki Nanjo,  
Wantapon Ngamdee, Masato Watanabe,  
and Eiki Hotta

*Department of Energy Sciences,  
Tokyo Institute of Technology*

# Motivation

NPR **decreases** as operating time **increases**



Problem for {  
NPR measurement  
long period of time operation

NPR vs. Operating time @ -20 kV 60 mA

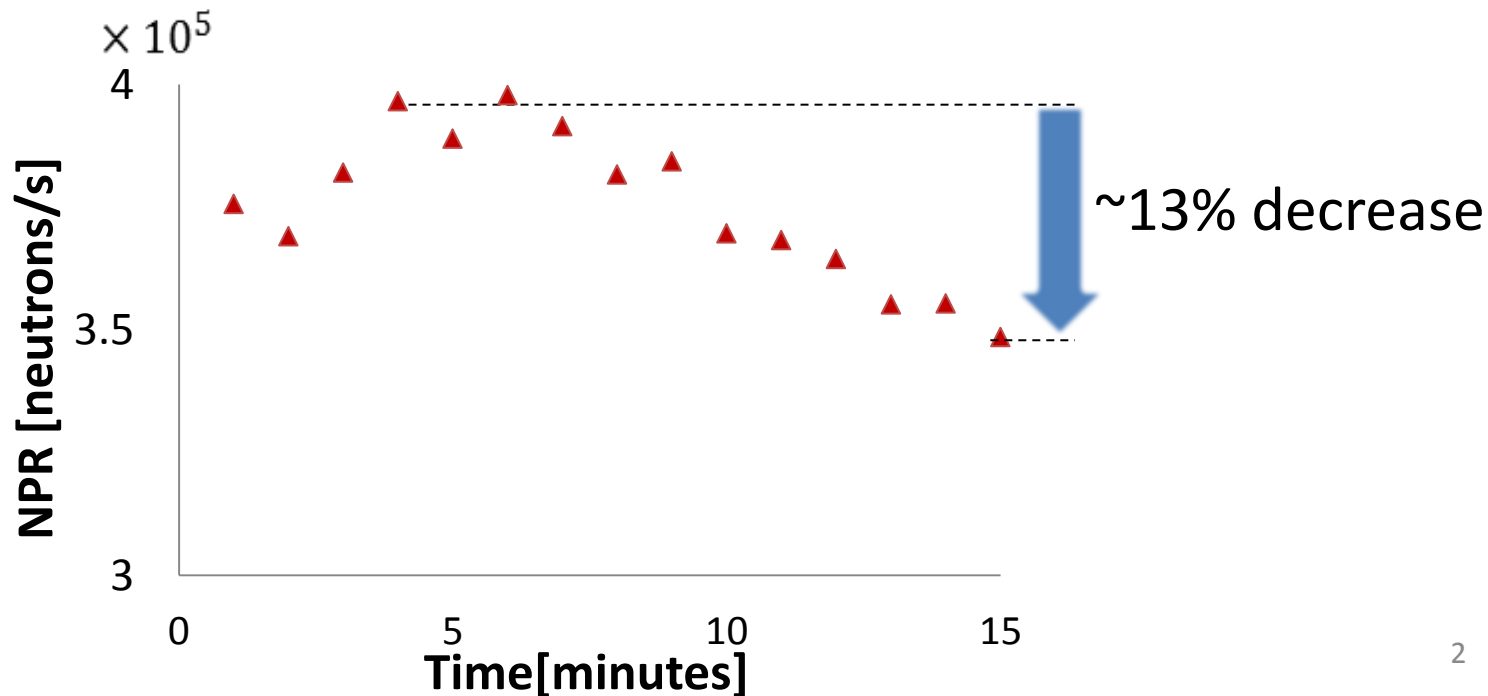

# Motivation 2

If we operate IECF device for a long period of time...

- Cathode temperature
  - Pressure
- } rises

Hypothesis

Cathode temperature affects **embedded fusion**

To prove the idea...

Cathode temperature was measured to calculate **deuteron density** on the surface of the cathode

# Experimental setup

## Cylindrical IECF device

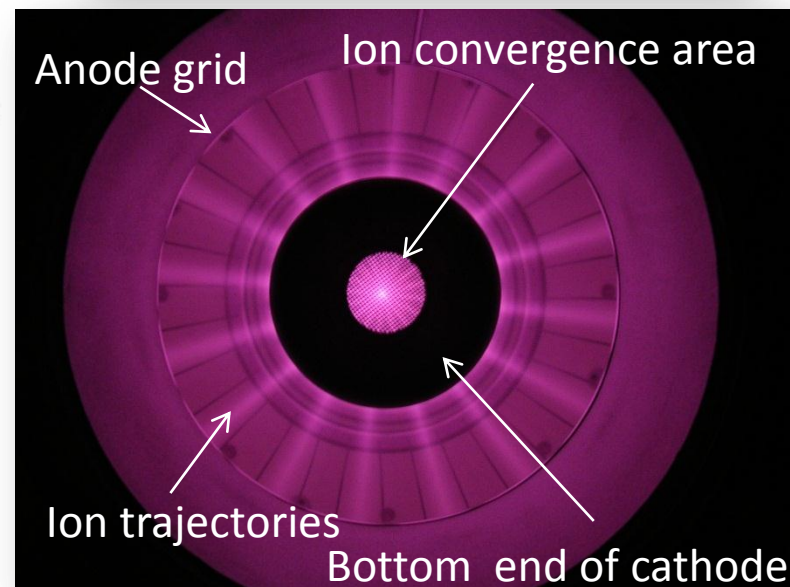
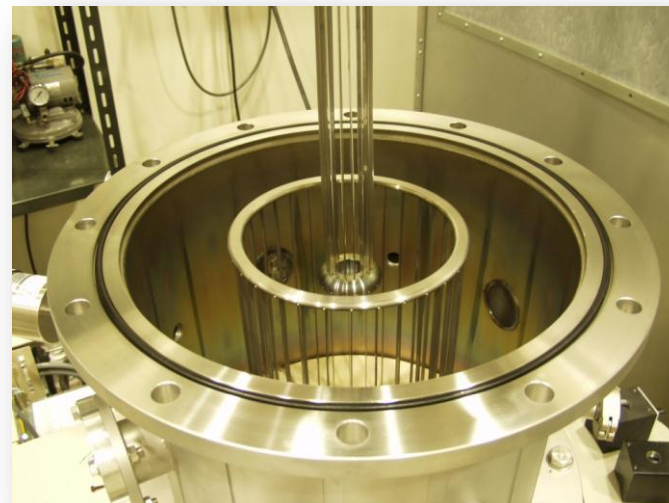
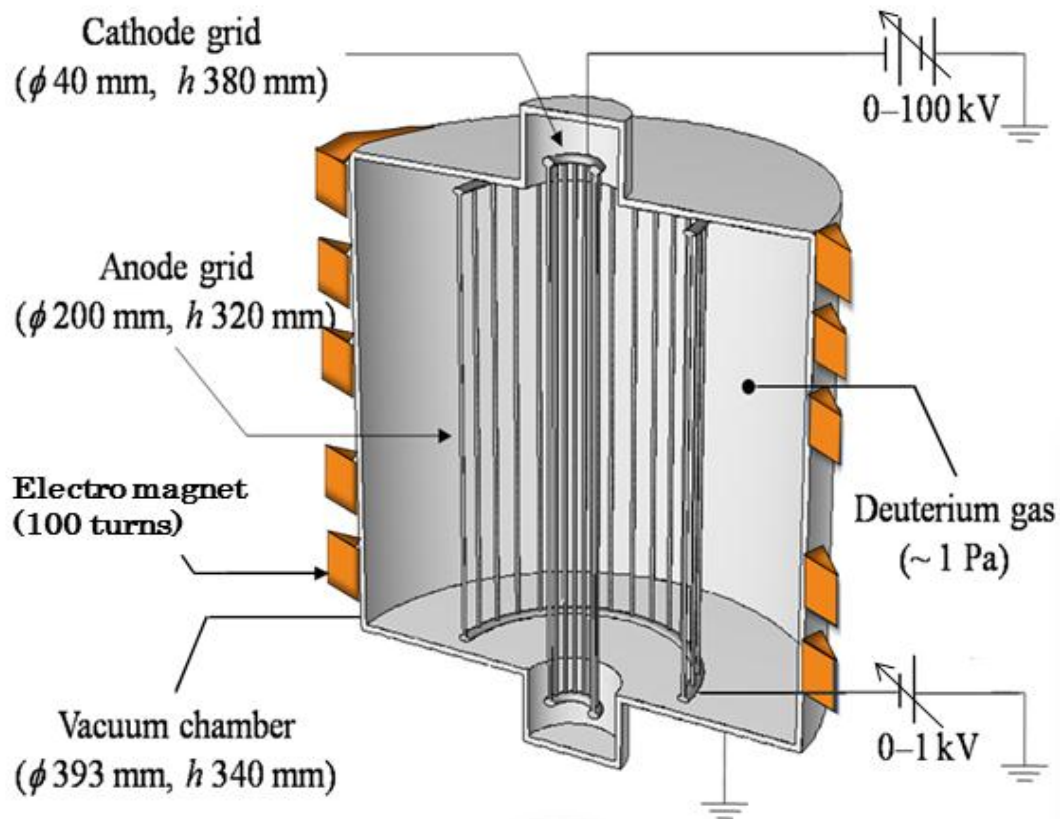

Observing from a bottom side

# Experimental setup 2

Radiation thermometer specs

Measurement range : 220~2000 °C

Wavelength 1.95~2 μm

Resolution : 3 °C

Measurement distance : 300 mm

Target diameter : 0.6 mm

- ✓ Emissivity was assumed as 0.74
- ✓ Plasma emission can be ignored

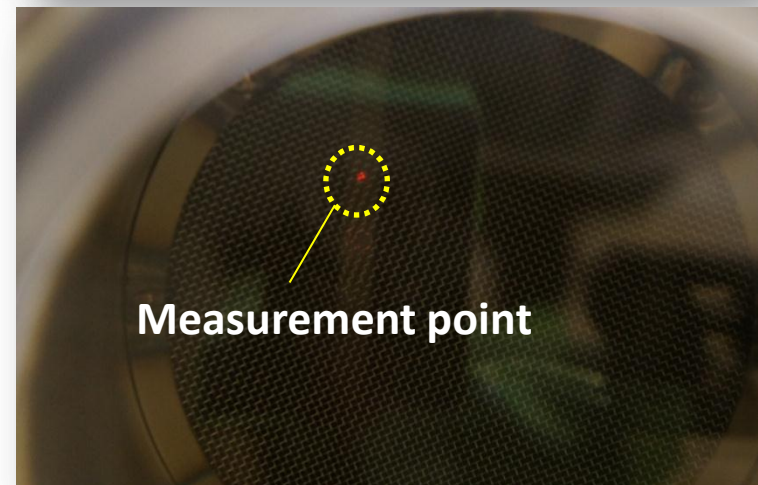
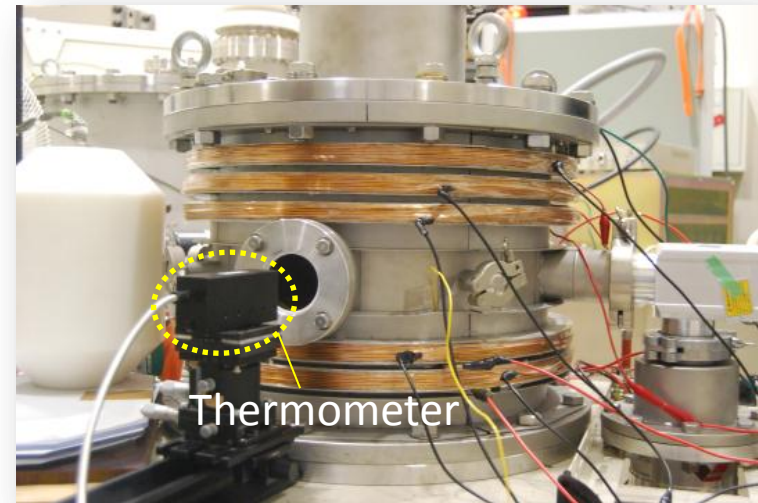
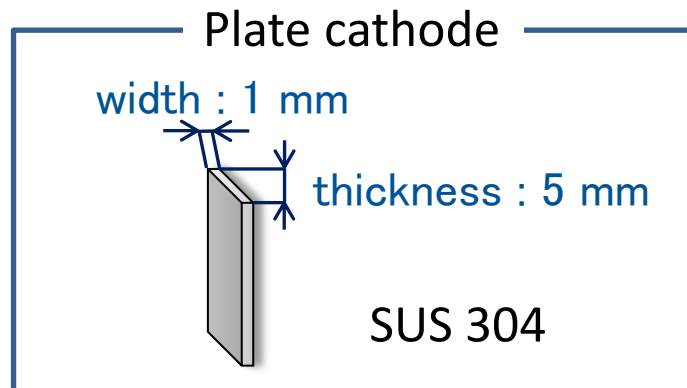

# NPR @ -20 kV

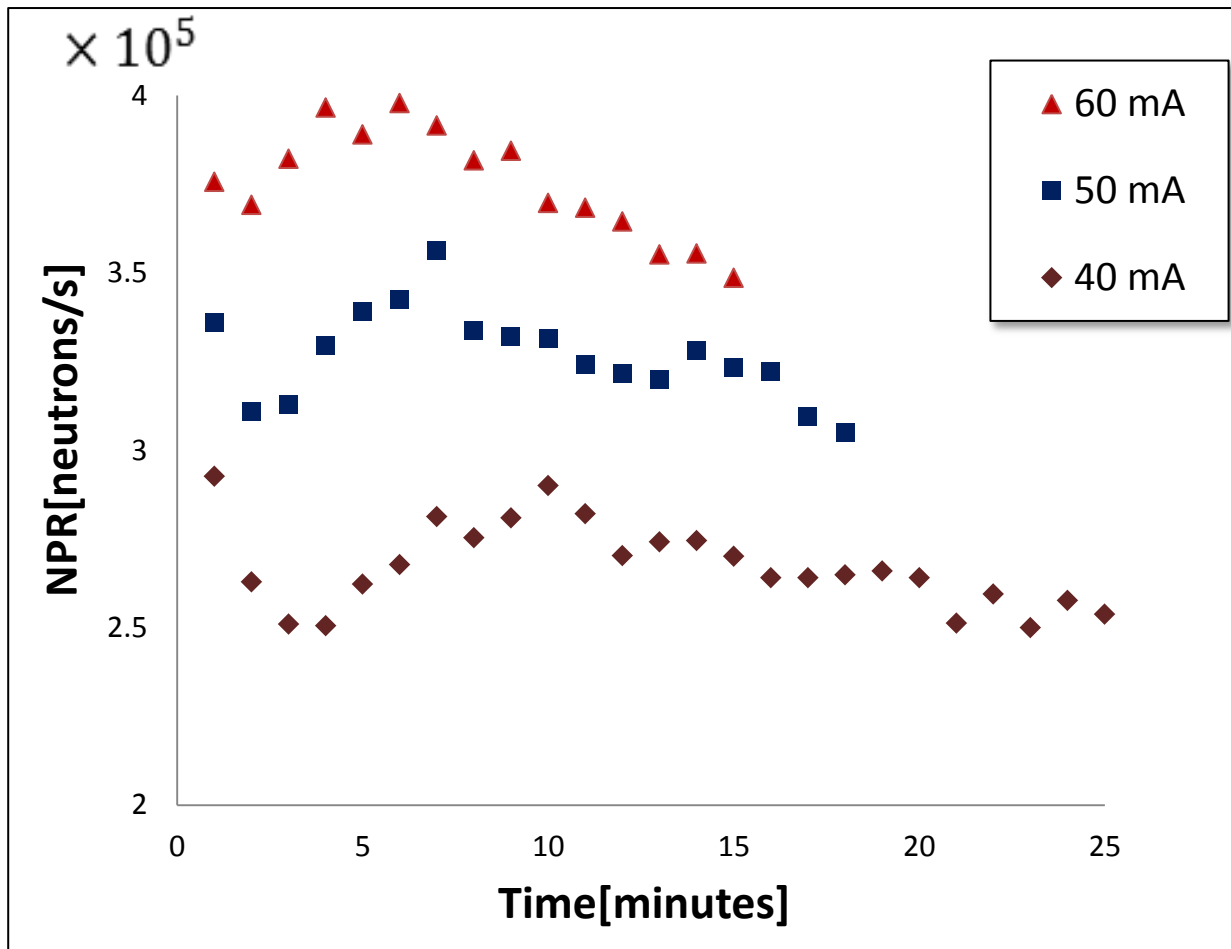

Higher input power makes the cathode hotter



Cathode temperature affects NPR

# Embedded fusion

Step 1

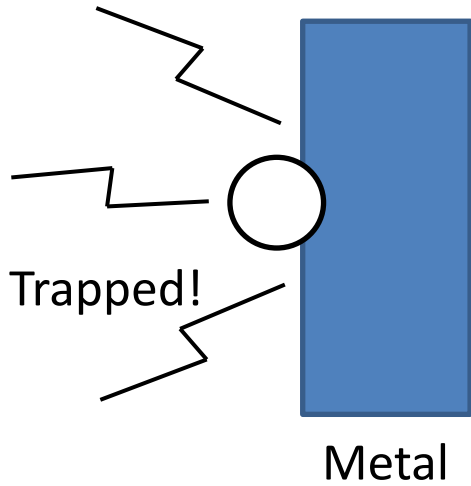

○ : Particle of fusion gas

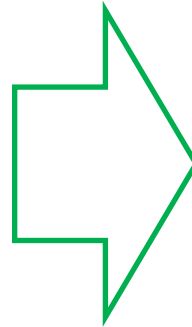

Step 2

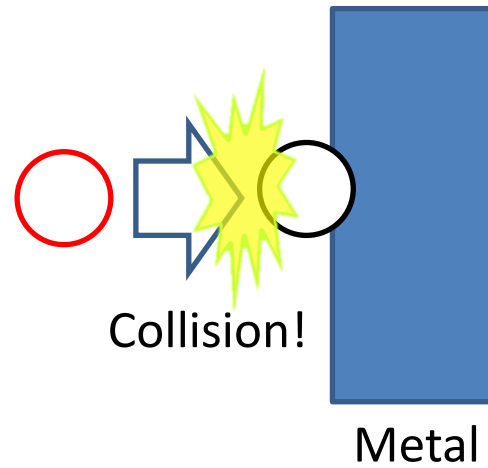

○ : Fast particle



# Relationship between NPR and deuteron density

Embedded fusion reaction rate  $R_{BM-C}$  can be described below

$$R_{BM-C} = \int_S \sigma n_{BM} \langle \Sigma v \rangle dS$$

$\sigma$  : Deuteron density on the cathode

$n_{BM}$  : Ion flux

$\Sigma$  : Cross section

$v$  : relative velocity

$R_{BM-C}$  increase and decrease can be estimated from  $\sigma$

$$\frac{d\sigma}{dt} = \text{Implant}(I, T_{gas}, P) - \text{Desorption}(\sigma, T_{cathode})$$

# Pressure @ -20 kV

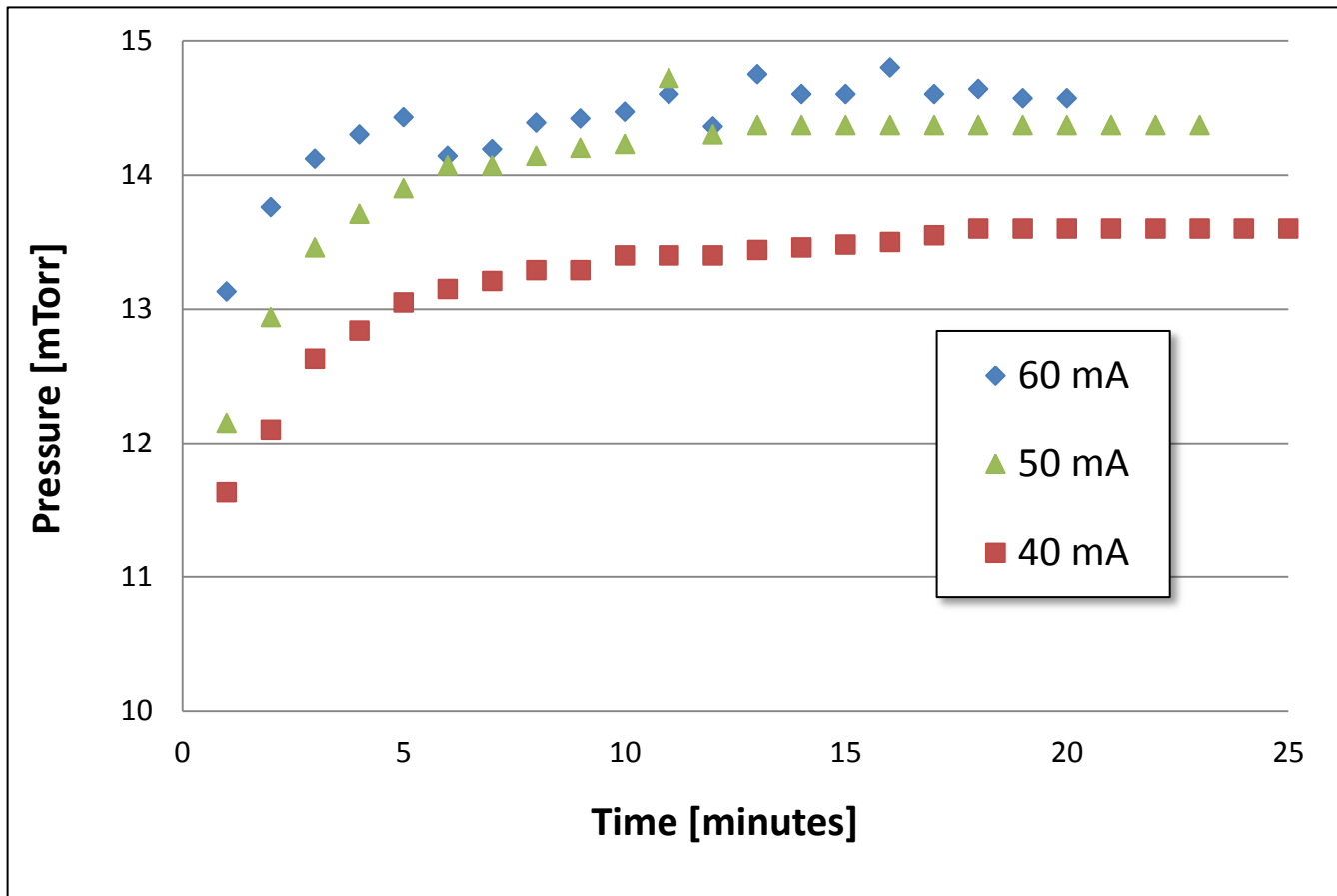

Pressure rises about 10% in every current condition

# Gas temperature @-20 kV

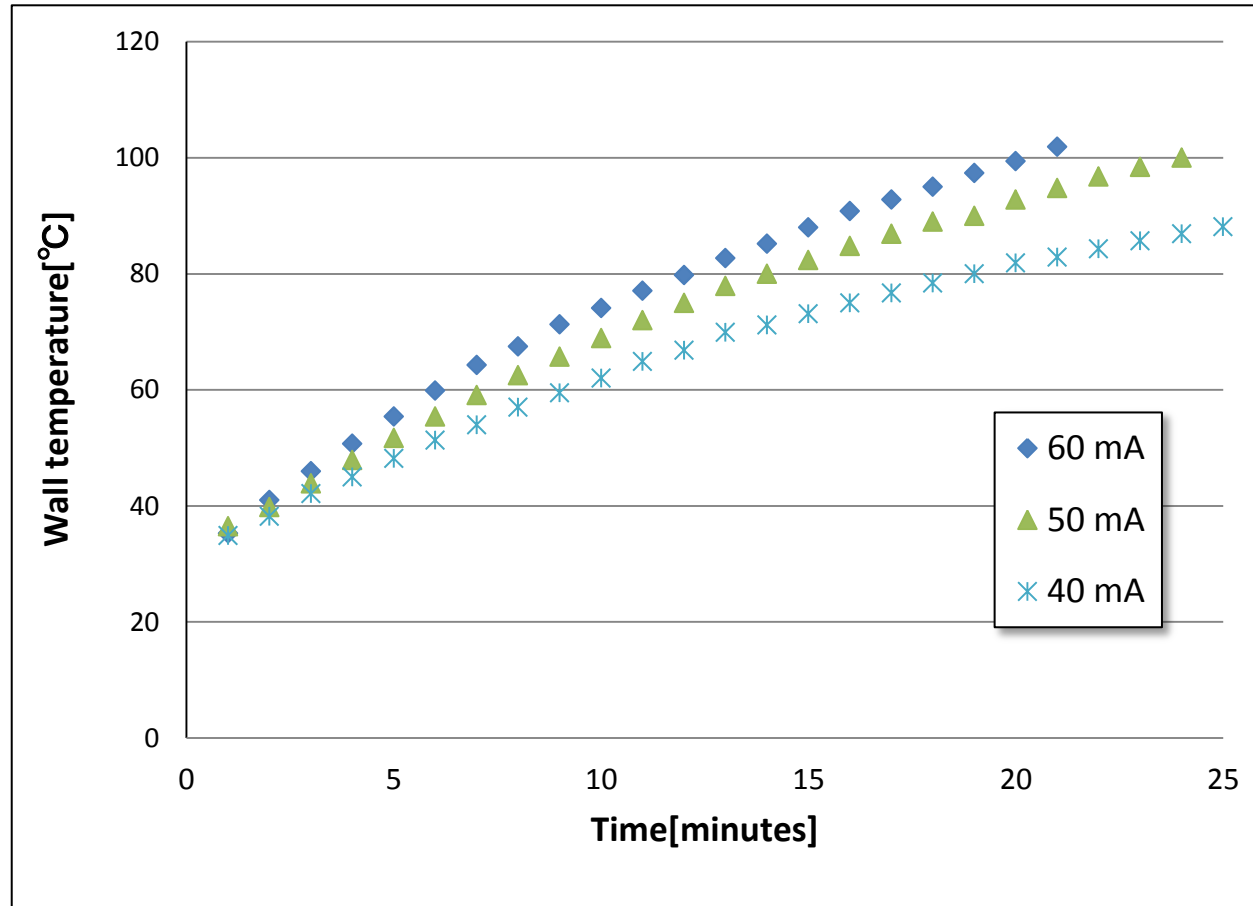

We assumed device wall temperature as gas temperature



# Cathode temperature @ -20 kV

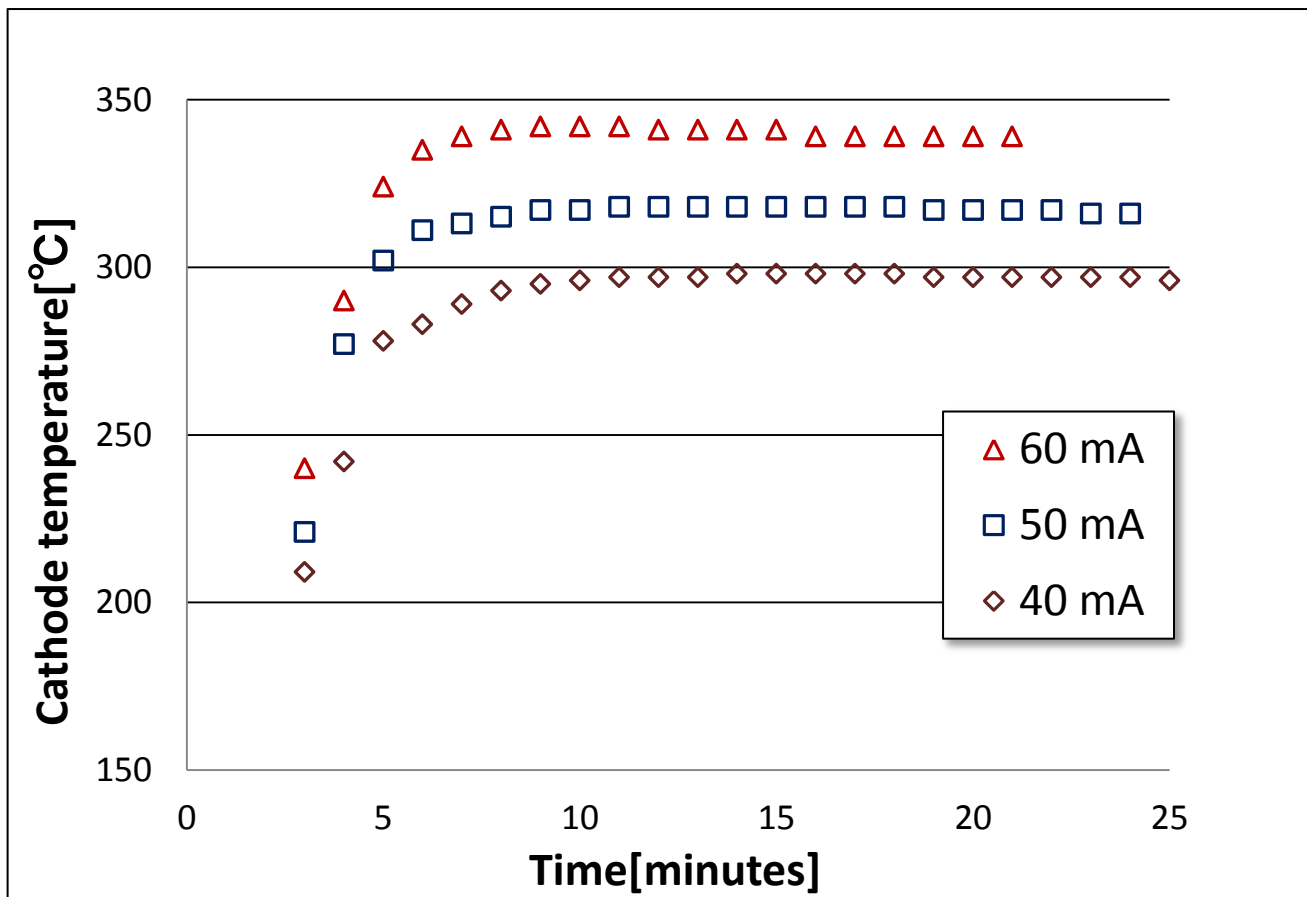

SUS(Cathode material)'s Melting point : about 1400 °C

# Deuterium trap on the cathode

## Adsorption

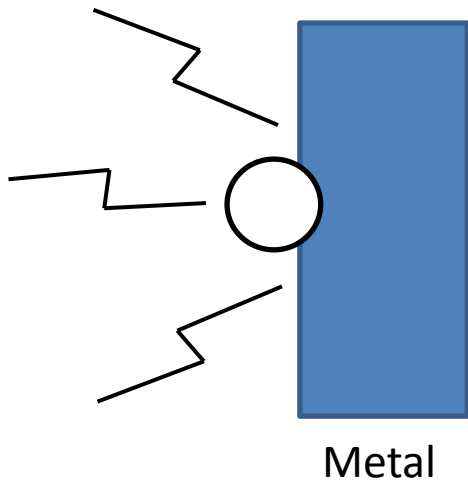

○ : Background gas molecule

## Embedment

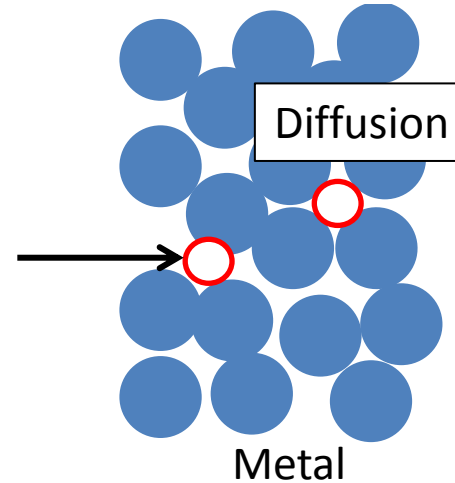

○ : Accelerated particle

- Physical adsorption
  - Van der waals attraction
  - Electro-static attraction
- Chemical adsorption
  - Ion binding

# Adsorption

Adsorption speed can be described below

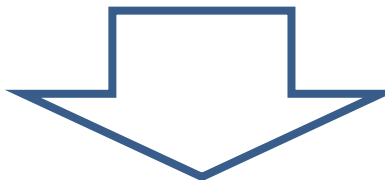
$$\left\{ \begin{array}{l} \frac{d\sigma}{dt} = \frac{1}{4} n \bar{v} s \\ \bar{v} = \sqrt{\frac{8kT}{\pi m}} = \sqrt{\frac{8RT}{\pi M}} \end{array} \right.$$

$\sigma$  : Deuterium density  
 $n$  : Molecule density  
 $\bar{v}$  : Average velocity of molecules  
 $T$  : Gas temperature  
 $s$  : Adsorption rate  
 $k$  : Boltzmann constant  
 $m$  : Mass of molecules  
 $M$  : Molecular weight  
 $R$  : Gas constant  
 $p$  : pressure

$$\frac{d\sigma}{dt} = 3.5 \times 10^{22} \frac{sp}{\sqrt{MT_{gas}}} \quad p \text{ [Torr]}, T_{gas} \text{ [K]}$$

# Embedment

Assuming  $\Gamma_{beam}$  as ion flux to the cathode,  
**embedment speed** can be described bellow

$$\frac{d\sigma}{dt} = A\Gamma_{beam}$$

$$\Gamma_{beam} = \frac{I}{CS} \times \frac{1}{1 + \gamma}$$

$\sigma$  : Deuterium density

$A$  : Ion embedment rate

$I$  : Cathode current

$C$  : Elementary charge

$S$  : Area of the cathode

$\gamma$  : second electron emission coefficient

We assumed  $A = 0.25$  and  $\gamma = 1$

$$\frac{d\sigma}{dt} = 7.8 \times 10^{14} \frac{I}{S}$$

Adsorption  $\approx 10^{19}$

Embedment  $\approx 10^{15}$

This effect could be stronger in spherical device



# Desorption

Desorption speed can be described below

$$-\frac{d\sigma}{dt} = -\sigma\nu \exp\left(-\frac{E_d}{RT_{Cathode}}\right)$$

$\sigma$  : Deuterium density  
 $\nu$  : Desorption reaction constant  
 $E_d$  : Activation energy of desorption  
 $R$  : Gas constant  
 $T_{Cathode}$  : Cathode temperature

Hydrogen – Tungsten desorption

$$-\frac{d\sigma}{dt} = -\sigma \times 2.2 \times 10^{13} \exp\left(\frac{-67 \times 10^3}{RT_C}\right)$$

# Summary of calculation

$$\frac{d\sigma}{dt} = 3.5 \times 10^{22} \frac{sp}{\sqrt{MT_{gas}}} + 7.8 \times 10^{14} \frac{I}{S} - \sigma$$

$$\times 2.2 \times 10^{13} \exp\left(\frac{-67 \times 10^3}{RT_c}\right)$$

We assumed  $s=0.1$  and  $\sigma(0)=0$

Value of  $s$  was said  $0.1 \sim 1$  in reference

# Result

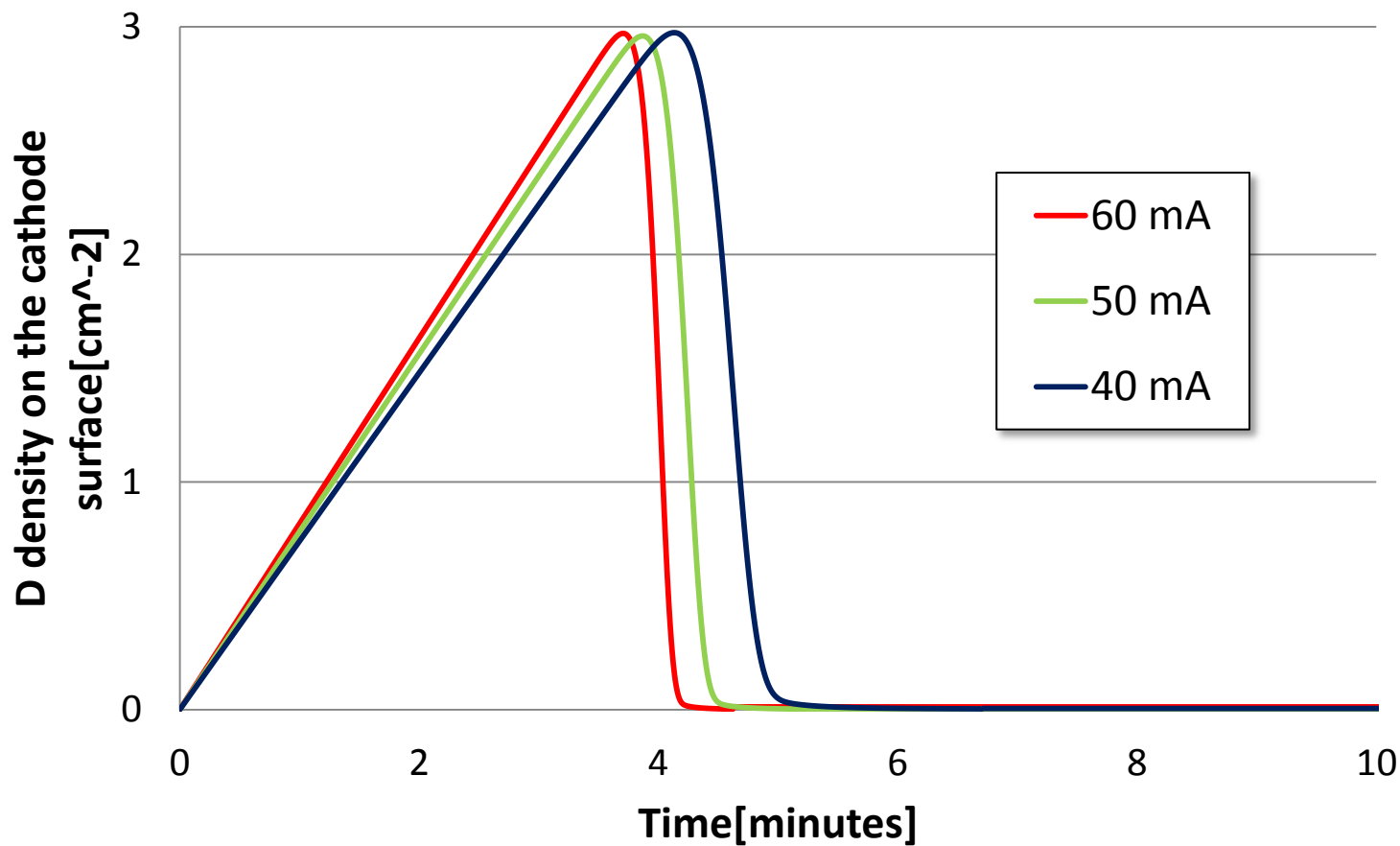

# Deuteron density and NPR vs. time

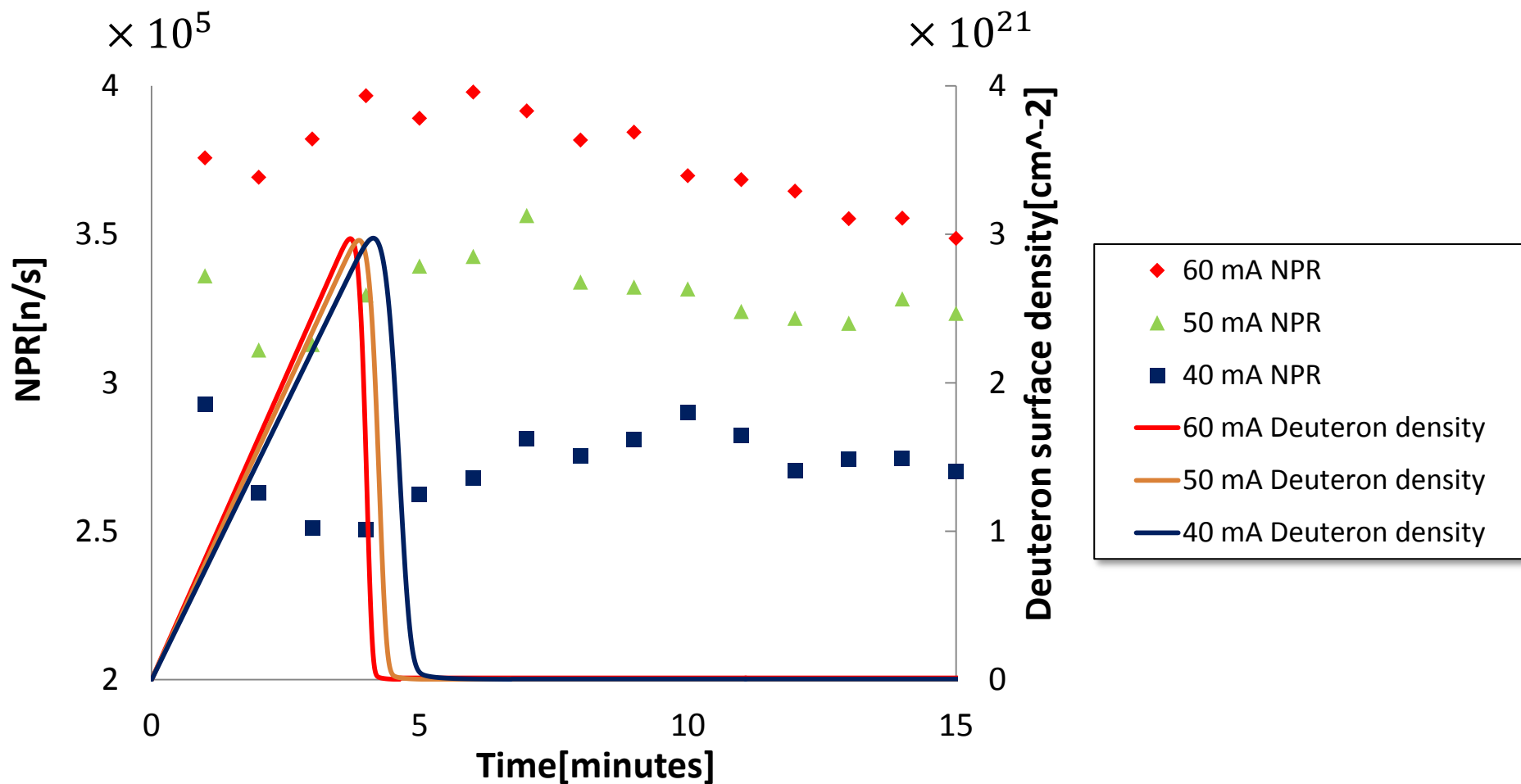

## How should we measure NPR?



We should run a IECF device until NPR become stable  
Measurement of NPR should be done after that

### Summary

- ✓ Introduced how to calculate deuteron density on the cathode.
- ✓ NPR vs. time tendency can be explained by embedded fusion on some level.

**Any questions or suggestions?**

Speak slowly, use easy word plz ;)

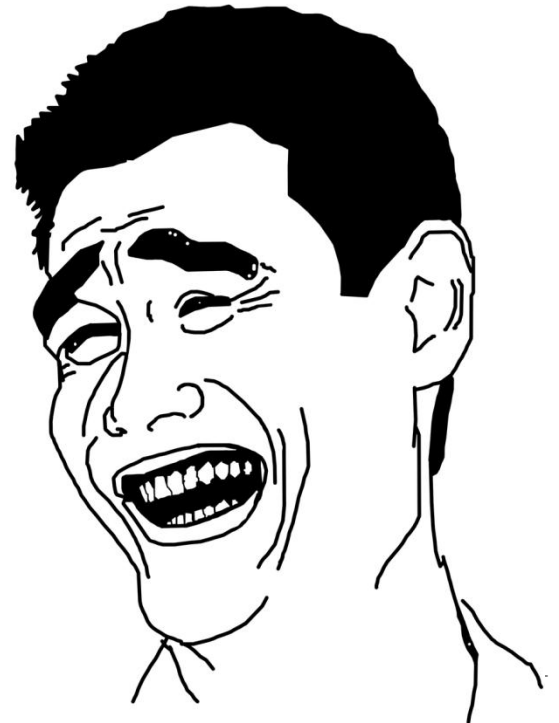



Reference

H.Kumagai, G.Tominaga : 「真空の物理と応用(Vacuum physics and applications)」

↓ Appendix

# Temperature calculation

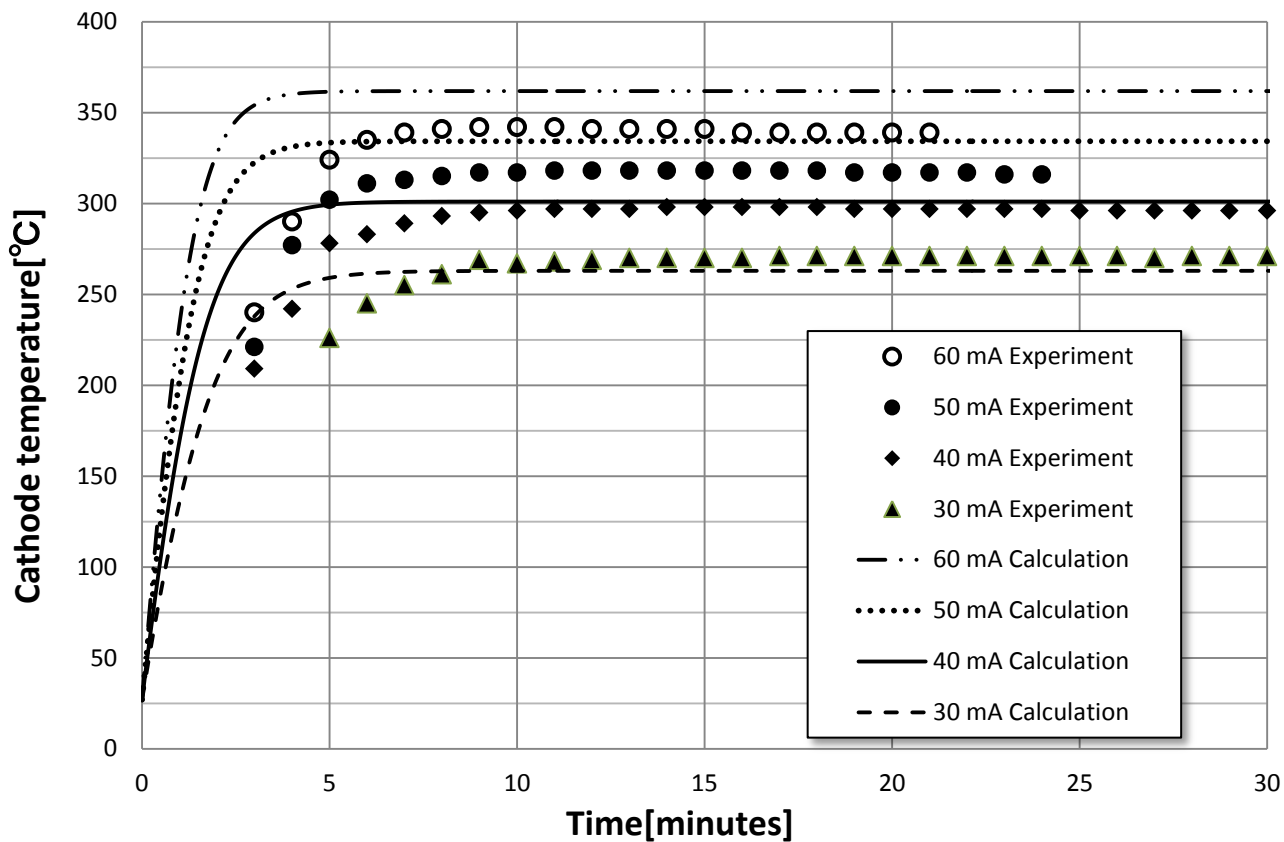

# Pulse operation

