

論文 / 著書情報
Article / Book Information

Title	Development of Unbonded Brace
Authors	Morihisa Fujimoto, Akira Wada, Eiichiro Saeki, Toru Takeuchi, Atsushi Watanabe
Citation	Quarterly Column, , No. 115, pp. 91-96
Pub. date	1990, 1

Development of Unbonded Braces

Morihisa FUJIMOTO, Akira WADA, Eiichiro SAEKI,
Toru TAKEUCHI, Atsushi WATANABE

1. PREFACE

The brace is probably one of the most popular earthquake- and wind-proof elements used with steel-framed structures. Earthquake- and wind-proof braces are used not only for structural reinforcement but for adding special effect to the appearance of structures. Not a few buildings have unique facades built by taking advantage of their effect on design; the Pompidou Center in Paris, the John Hancock Center in Chicago, and the Bank of China Building in Hongkong, to name a few.

It is generally known that brace frames economically provide adequate rigidity and strength in a horizontal direction. In Japan, however, use of braces is largely limited to medium- and small-sized structures, with larger buildings mostly build on rigid-frame or Rahmen structures. Let us consider the reason for this.

First, larger buildings in Japan, a heavily earthquake-ridden country, are built according to elastic-plastic design. Braces that buckle are difficult to handle with plastic design because their yield stress drops after yielding under compressive loading. If the slenderness ratio of braces is increased to take advantage of their tensile strength only, they do not afford much energy absorption because of their slip type hysteresis characteristics. If cross sections are made large enough to avoid buckling, greater stress concentration results, with the appearance of buildings tending to become more bulky or rugged.

Braces can effectively control the rigidity and strength of high-rise buildings, in particular. Actually, however, their use is substantially limited because of the aforementioned problems. Braces are often used as multi-storied earthquake-proof walls

that cause boundary beams to yield first (Fig. 1). While the earthquake-proof walls are bent to yield at their base, the braces themselves remain unbuckled until adequate plastic deformation has been attained. Even with this type of design, buckling ultimately occurs in columns or elsewhere. Also, braces with larger cross sections no longer possess their inherent rigidity control function.

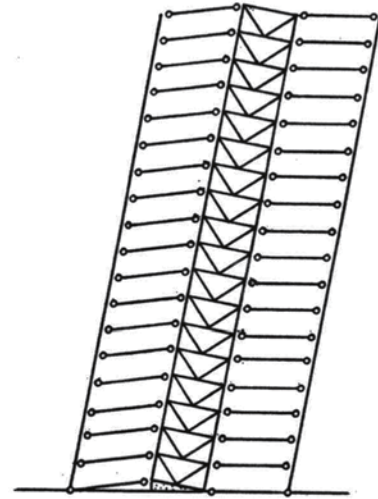

Fig. 1 Bend-collapsible multi-storied earthquake-proof walls

To solve this problem, various approaches have been contemplated and materialized to impart an ability to undergo plastic deformation to the earthquake-proof walls themselves. Typical examples are the earthquake-proof walls made of steel plates, eccentric K-shaped braces and prestressed-concrete earthquake-proof walls containing various kinds of plastic materials shown in Fig. 2. These earthquake-proof walls themselves serve as a structure to absorb the energy of earthquake without losing their function to control strength and rigidity. Still, they are not without shortcomings. They are difficult to model and design and their construction require considerable time and labor.

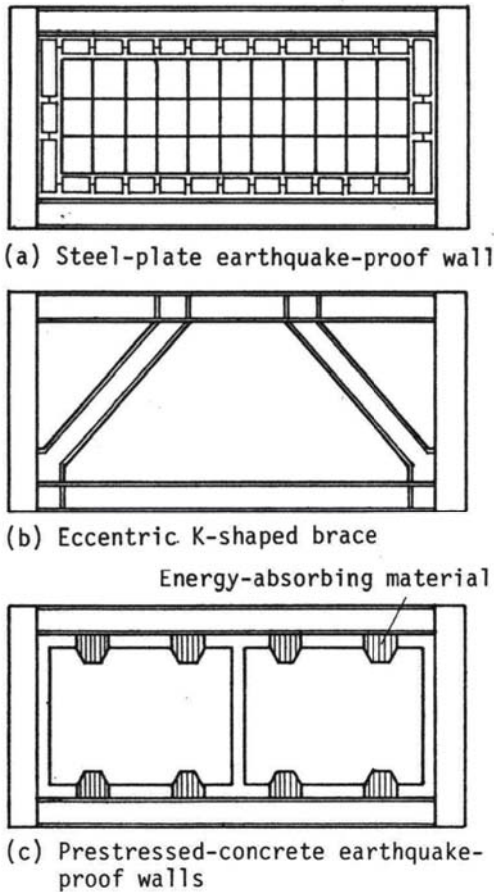

Fig. 2 Energy-absorbing earthquake-proof walls

On the other hand, several attempts have been made to avoid the buckling of braces. Kimura et al.¹⁾, for example, confirmed that stable hysteresis characteristics can be obtained with a conventional brace encased in a square steel pipe, with the space left therebetween filled with mortar. But the deformation of the mortar is not enough to absorb a change in the cross-sectional area that occurs after the yielding of the brace. When the cross section restores to its original state, therefore, the yield stress on the compressive side increases more than on the tensile side. When such changes repeat, the end of the brace is repeatedly pulled outward, bringing about a localized buckling and a drop in yield stress in that region.

Mochizuki et al.^{2),3)} made experiments on the inhibition of the buckling of diagonal bracing wrapped with reinforced concrete, with the concrete kept from adhering to the bracing by use of a shock-absorbing material. When sub-

jected to repetitive loading, however, the concrete cracks to weaken its buckling preventing effect. Then, the brace reportedly becomes more susceptible to buckling.

By refining this concept, the authors developed a new type of brace (hereinafter called the unbonded brace) that does not buckle because of an encasing steel pipe and concrete which, in combination, have a stable ability to restore the original condition. This brace comprises a steel core member at the center (hereinafter called the core member) and a combination of a steel pipe and concrete filled therein in order to isolate the core member from other frames and core braces to prevent the transmission of axial forces, thereby preventing the buckling of the brace (Fig. 3). The new unbonded braces are easy to model and simple in design as braces essentially should be. They also exhibit completely symmetrical and stable hysteresis characteristics under compressive and tensile forces.

This paper deals with the results of fundamental and application experiments and analysis on the new unbonded braces and their application to actual buildings. It also proposes a new type of frame design based on the use of the unbonded braces.

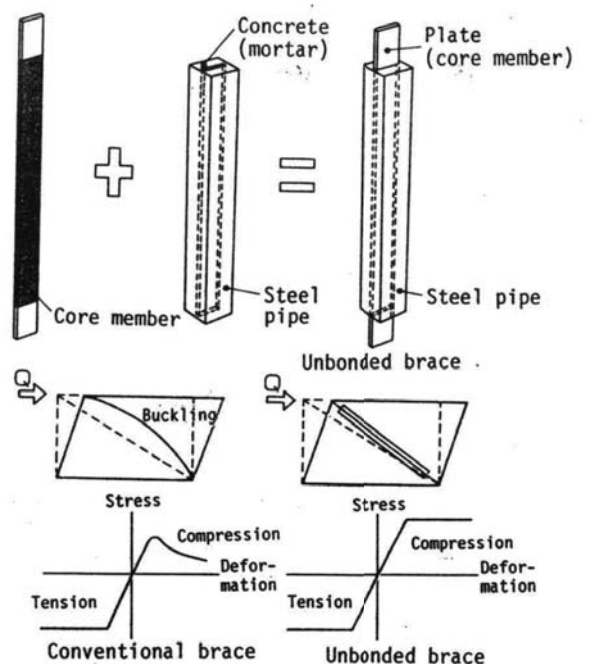

Fig. 3 Unbonded braces

2. FUNDAMENTAL EXPERIMENT

An experiment to grasp the basic characteristics of the unbonded braces was made before putting them to practical application. The following is a summary of the experiment.

2.1 Specimen and Experimental Method

The specimen was prepared by encasing a steel core member in a square steel pipe filled with concrete, as shown in Fig. 4. The core member was made of rolled steel for general structure according to JIS G 3101 SS41 which proved to withstand a yield stress of 2880 kg/cm^2 . The square steel pipe was a carbon steel square pipe for general structural purposes according to JIS G 3466 STKR 50 which proved to withstand a yield stress of 3700 kg/cm^2 . To isolate the concrete from the frame, the core member was exposed at both ends of the specimen. In order to prevent the occurrence of localized buckling in that region, both ends of the core member were cross-shaped and thrust into the pipe as shown in Fig. 5. To ensure that this buckling stopper does not transmit the axial force to the steel pipe and concrete, axial clearance was secured by use of expandable polystyrene. Also, a coating material to absorb a cross-sectional expansion when the core member has

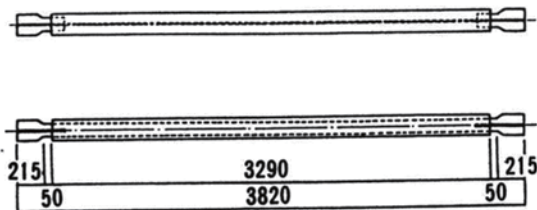

Fig. 4 Specimen

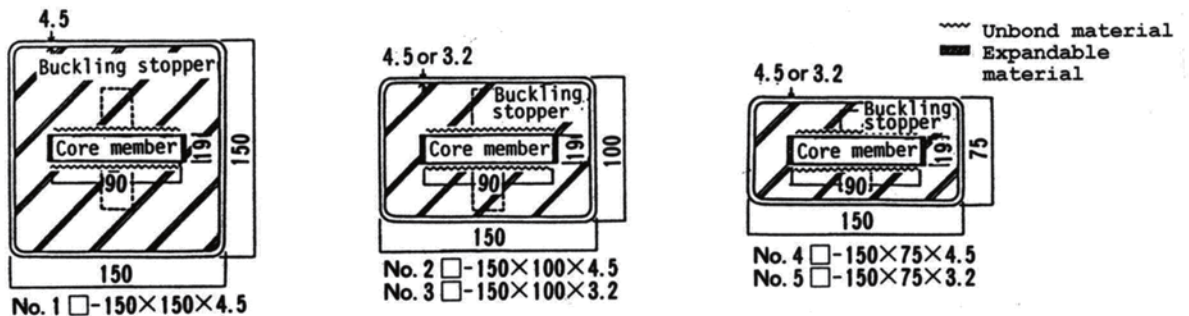

Fig. 6 Cross sections of specimens

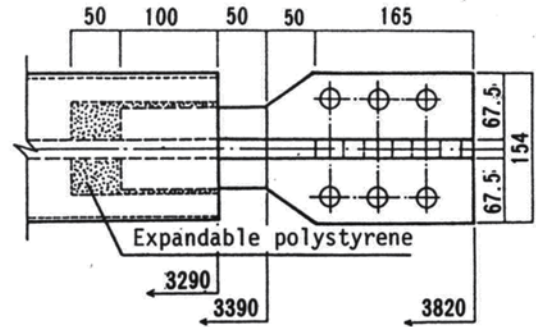

Fig. 5 Detailed view of an end of a specimen

started plastic deformation was provided between the concrete and the core member. This provision prevents axial force from getting transmitted to the steel pipe and concrete by friction, too. unbond material on the narrower sides of the core member and 3 mm thick sheets of expandable material on its wider sides served as the coating material. Five specimens for compressive test were prepared by encasing a core member of the same cross-sectional area, 19 mm by 90 mm, in steel pipes of different cross-sectional areas, as shown in Fig. 6, thereby varying the ratio of the Euler load P_E on the steel pipe alone to the yield stress P_y of the core member between 0.55 and 3.82. Table 1 shows the theoretical yield stress of the five specimens. The experiment was conducted by placing each brace in a frame, as shown in Fig. 7 and Photo 1. As the brace is pinned to the upper end of one column of the frame and the lower end of the other column, bending moment affects the ends of the brace as the frame deforms, as in actual structures.

Horizontal force was applied to the frame using a 110-ton actuator.

Table 1 Theoretical yield strength and experimental results

Specimen No.	Variable	Theoretical Yield Strength					Experimental Results						
		Steel Pipe		Core Member		P_E / P_y	Tensile Yielding		Compressive Yielding		Buckling		
	Pipe Dimension B x D x t (mm)	Second Moment of Area I_k (cm ⁴)	Buckling Load P_E (ton)	Cross-sectional Area, A (cm ²)	Yield Load P_y (ton)		Load P_t (ton)	P_t / P_y	Load P_c (ton)	P_c / P_y	Load P_{cr} (ton)	P_{cr} / P_y	P_{cr} / P_E
No. 1	150 x 150 x 4.5	896	171.0	16.84	48.50	3.53	48.6	1.00	51.5	1.06	-	-	-
No. 2	150 x 100 x 4.5	352	67.4	16.84	48.50	1.39	48.3	1.00	51.8	1.07	-	-	-
No. 3	150 x 100 x 3.2	262	50.2	16.88	48.61	1.03	47.6	0.98	49.3	1.01	-	-	-
No. 4	150 x 75 x 4.5	183	35.0	16.84	48.50	0.72	48.3	1.00	-	-	46.5	0.95	1.33
No. 5	150 x 75 x 3.2	137	26.2	16.62	47.87	0.55	47.9	1.00	-	-	43.1	0.90	1.65

Yield strength and rigidity of mortar were neglected because mortar theoretically cracks when subjected to repetitive loading.

Euler buckling load $P = \frac{\pi^2 E I_k}{l^2}$

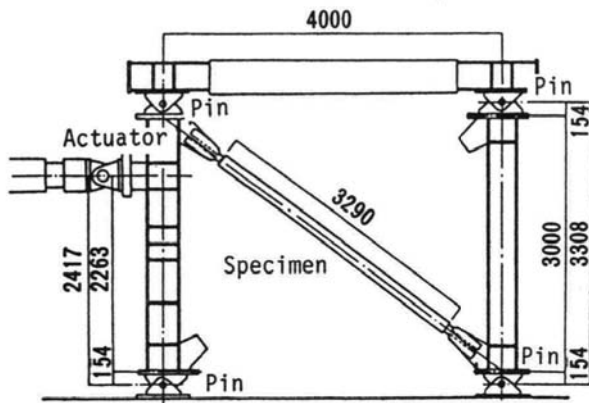

Fig. 7 Testing machine

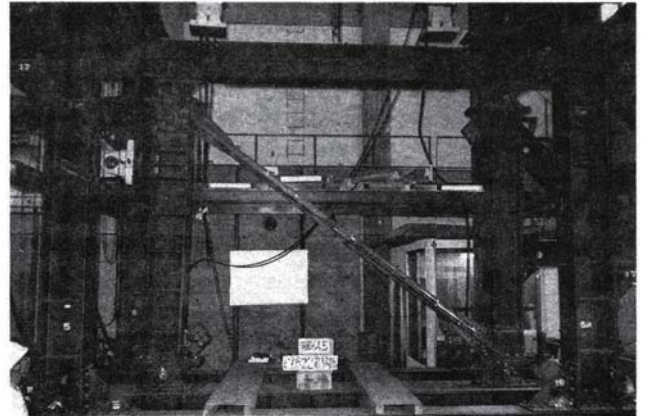

Photo. 1 Testing machine

Alternating loading was repeated eight times, with permanent and temporary loads allowable to the core member and in the range in which the maximum gradient of displacement between layers varies between 1/400 and 1/50.

The axial displacement of the brace, its deflection in the direction of the weaker axis, and the slip-out of the core member from the concrete in the steel pipe were measured. Axial deformation in eight cross sections of the core member and three cross sections of the steel pipe as well as circumferential deformation in the center cross section of the steel pipe were measured.

2.2 Experimental Results

The results of the experiment are shown in the second half of Table 1. The specimens (Nos. 1 to 3) in which

the buckling strength of the steel pipe exceeded the yield stress of the core member did not buckle under compressive forces. They absorbed much energy and showed stable symmetrical hysteresis characteristics as shown in Figs. 8 to 10. As shown by the hysteresis curve on the tensile side, load increased at the same incline as the elastic rigidity of the core member. The brace yielded when the loaded reached the yield point of the core member. A similar tendency was observed on the compressive side, too, though the yield stress was somewhat higher than that of the core member. The gradient of displacement between layers on yielding was approximately 1/500. Even with the gradient of ultimate displacement between layers at 1/50, the specimens exhibited stable characteristics. Thus, their hysteresis characteristics proved analogous to those of ordinary rigid frame members that deform at

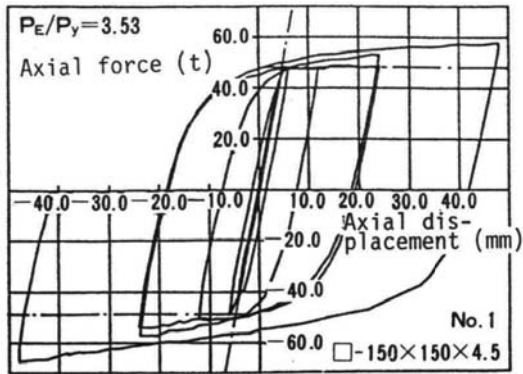

Fig. 8 Relationship between the axial force and axial displacement of the brace - No. 1

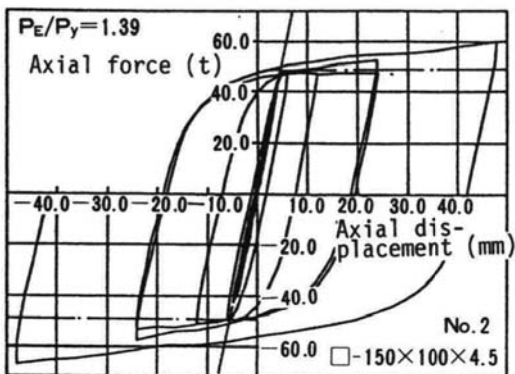

Fig. 9 Relationship between the axial force and axial displacement of the brace - No. 2

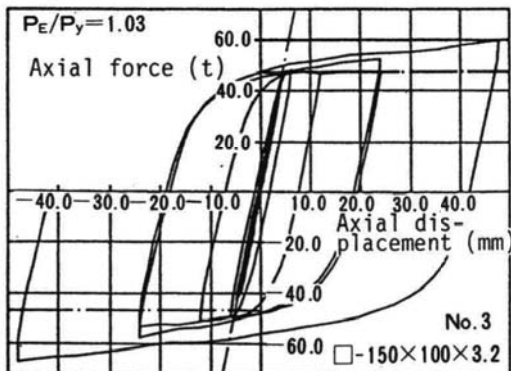

Fig. 10 Relationship between the axial force and axial displacement of the brace - No. 3

gradients of 1/200 to 1/50. Almost analogous hysteresis curves were obtained for the three different specimens irrespective of the size of their steel pipes because their core members had the same cross-sectional area.

The following findings were obtained with regard to the adhesion

between the core member and the encasing concrete filled in the steel pipe: The initial rigidity of the brace agreed substantially to that of the core member alone. The measured strain showed that only about 5 percent of the total axial force was transmitted to the encasing concrete and steel pipe even under compressive force. All this evidenced the isolating effect of the coating material.

After the test, the steel pipe and concrete were removed to investigate how the core member has deformed. The yielded core member was found to undulate widthwise throughout its entire length within the width of the expandable polystyrene used as the coating material. But this deformation was confined by the surrounding concrete. Also, the yielding of the core member was uniform, as was obvious from the distribution of its strain that did not vary greatly. As such, the undulation of the core member does not seem to have any significant effect on the hysteresis characteristics of the whole brace. This point will be discussed further later.

In the specimens (Nos. 4 and 5) in which the buckling strength of the steel pipe was lower than the yield stress of the core member, the whole brace buckled before the core member yielded under compression, with a sharp decrease in yield stress as shown in Figs. 11 and 12. The buckling load was 46.5 tons for No. 4 and 43.1 tons for No. 5, respectively accounting for 96 percent and 90 percent of the yield stress of the core member.

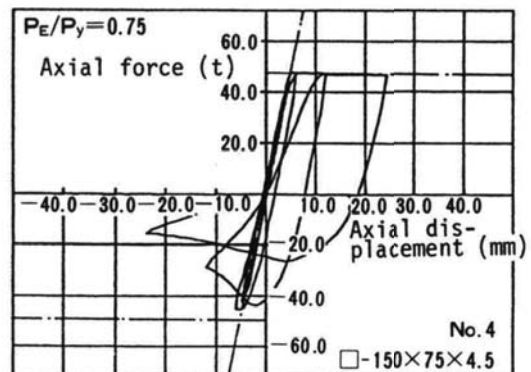

Fig. 11 Relationship between the axial force and axial displacement of the brace - No. 4

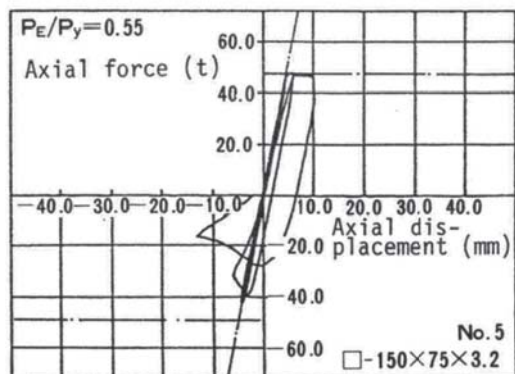

Fig. 12 Relationship between the axial force and axial displacement of the brace - No. 5

Once buckling occurs, the core member curved under compression, creating a frictional force between the core member and the surrounding concrete and transmitting the axial force to the concrete encased in the steel pipe. As a consequence, the hysteresis curve exhibited by the tested specimens looked like ones that appear when an ordinary brace buckles. When subjected to tension, however, adhesion was broken again even after buckling, whereby only the core member yielded. Then, tensile strain built up in the core member, increasing the amount of slip-out at its both ends.

Photo 2 shows the condition of the specimens after the test.

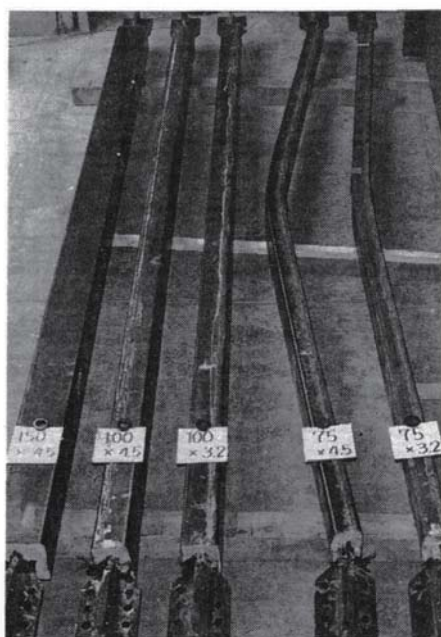

Photo. 2 Unbonded braces after ultimate deformation

3. ANALYSIS AND DESIGN EQUATIONS

3.1 Behavior of Core Member in Concrete Encased in Steel Pipe

No total buckling occurs if the Euler buckling load of the concrete encased in the steel pipe fundamentally exceeds the yield stress of the core member because the axial force is not transmitted to the concrete even if the core member is subjected to compressive force. To take advantage of the yield stress of the core member, however, its buckling in the concrete must be prevented. In relation to the buckling behavior of the core member in the concrete encased in the steel pipe, the following requirements must be fulfilled:

- (a) The concrete filled between the steel pipe and the core member must be rigid enough so that the core member should not cause buckling of short wave in the steel pipe thrusting aside the concrete.
- (b) Even if the concrete is rigid enough, the core member can become wavy in the gap filled with the coating material. But this wavy deformation should not affect the hysteresis curve of the brace.
- (c) The bending moment that results when the wavy deformed core member comes in contact with the concrete should not yield the steel pipe and, then, lower its buckling restraining effect.

In relation to (a), let us assume that the steel pipe is sufficiently rigid. Then, the concrete between the steel pipe and the core member functions like a number of elastic springs (forming an elastic floor) continuously disposed along the axis of the core member as shown in Fig. 13. Spring constant β per unit is derived by dividing the product of the Young's modulus of the concrete on the compressive side alone by the width of the core member by the thickness of the concrete between the core member and the steel pipe wall on one side.

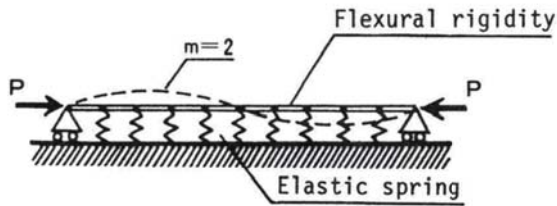

Fig. 13 Buckling of a bar moving like an elastic floor

By regarding this case as a problem concerning the buckling of a bar placed on an elastic floor, the buckling load P_m of the core member according to the number m of half sinusoidal waves segmented as a result of buckling can be expressed as follows:

$$P_m = \frac{\pi^2 E I}{l^2} \left(m^2 + \frac{\beta l^4}{\pi^2 m^4 E I} \right) \quad (1)$$

Fig. 14 shows general cases expressed by equation (1), with the value of m varied from 1 to 7. If the minimum value P_{min} of each curve is higher than the yield stress of the core member, the yield stress will increase up to the yield point P_y of the core member without causing buckling of short wave length in the steel pipe. The minimum value P_{min} can be expressed by equation (2), independent of l and m .

$$P_{min} = 2 \sqrt{BET} \quad (2)$$

With experiment No. 1, in which the concrete on one side of the core member had a thickness of 6 cm, a width of 9 cm and a Young's modulus of 210 tons/cm², $\beta = 315$ tons/cm². Hence, $P_{min} = 1170$ tons, which was large enough

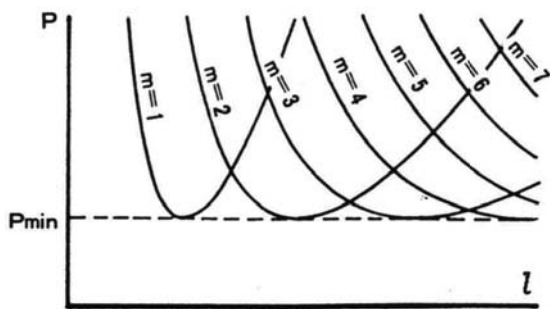

Fig. 14 Buckling load working on a bar moving like an elastic floor

compared with the yield stress $P_y = 48.5$ tons of the core member. When calculated backward, the value of β that allows such deformation of the core member in the concrete to take place before yielding is 0.55 tons/cm². As this is less than 1/500 of the value of β obtained in experiment No. 1, P_m will not fall below P_y even on the assumption that the concrete serves as a spring that is only 1/100 as hard. Thus, concrete is hard enough to restrain the deformation of the core member encased in the steel pipe.

Let us now consider problem (b). When a core member is subjected to a compressive force in a rigid cylinder with a clearance left therebetween, the core member that is going to buckle strikes the wall of the cylinder, describing a primary waveform. Then, the buckling core member continues to describe waveforms of higher orders (Fig. 15). The relationship between load and deformation can be determined by calculating the axial force and axial deformation at points where buckling waveforms of different orders appeared. In the calculation, Johnson-Euler load should be used as the buckling load. For axial deformation, the sum of (deformation due to axial strain) + (axial deformation due to buckling waveform) is determined by assuming that the buckling waveform is that of a sinusoidal wave.

Fig. 16 shows load-deformation curves for a core member, with a width of 250 mm, a thickness of 25 mm and a

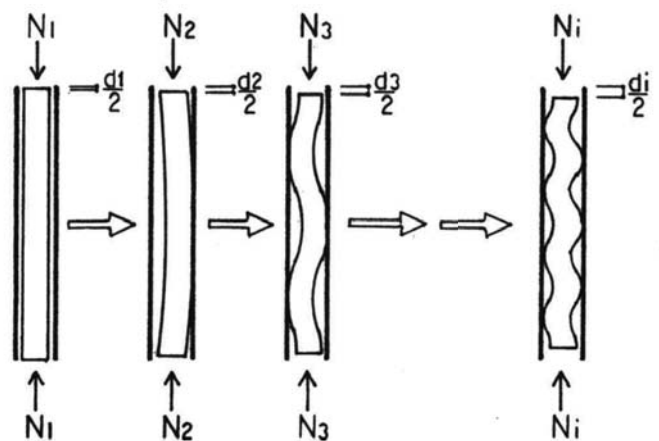

Fig. 15 Wavy buckling of a core member

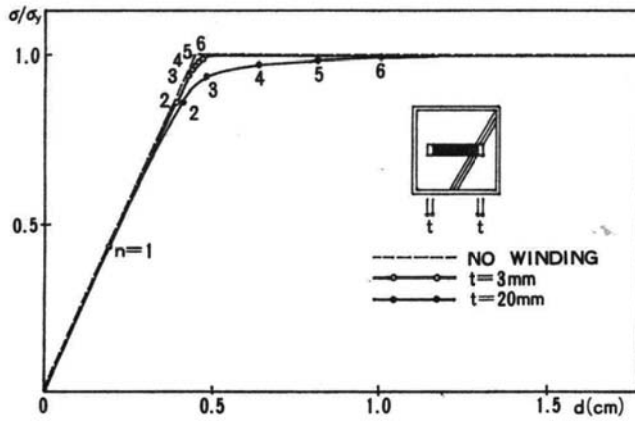

Fig. 16 Effect of the wavy deformation of the core member (on axial force)

length equal to that of the steel pipe, placed with a clearance of 3 mm and 20 mm left on both sides. The curve with a clearance of 20 mm exhibited some significant difference from a theoretical curve obtained under a tensile axial force. But the difference with a clearance of 3 mm, with which the experiment was carried out, was substantially negligible. Thus, it may safely be considered that the effect the wavy deformation of the core member in the clearance left in the surrounding concrete exerts on the hysteresis curve of the brace is negligible.

Now let us consider problem (c) about the stronger axis of a core member encased in concrete with a large clearance left therebetween. With expandable polystyrene having a thickness d , the maximum moment that works thereon when a core member in a steel pipe buckles can be expressed as $P_y \cdot d$ as shown in Fig. 17. The moment increases as the clearance on both sides of the core member increases. In the experiment conducted, the moment was approximately 15 t.cm at 48.5 t x 3 mm. This is adequately smaller than the plastic moment M_p of the steel pipe (for example, the smallest M_p observed among the unbuckling specimens was 240 t.cm with specimen No. 3).

The loosely encased core member may deform in the steel pipe, creating a bending moment working on the steel pipe. But the bending moment does not cause the steel pipe to yield or lowers its buckling restraining effect.

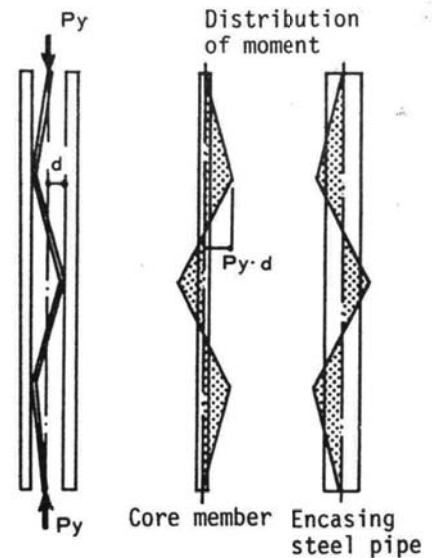

Fig. 17 Effect of the wavy deformation of the core member (on the encasing steel pipe)

3.2 Requirements for Avoiding Total Buckling

It became clear that the braces of the cross-sections tested had high enough effect to restrain the buckling of the core member in the concrete encased in the steel pipe.

Therefore, an unbonded brace will show as much yield stress even under a compressive axial force as is comparable to its tensile strength if the concrete encased in a steel pipe is designed to have a Euler buckling strength higher than the yield stress of the core member. Buckling of unbonded braces can be judged by use of the following equation, with consideration given to the specification of the steel structures in Japan into which they are assembled.

$$\frac{N_u}{A_k} \geq \frac{0.277F}{(\lambda/\Lambda)^2} \quad (3)$$

N_u = Yield stress of the core member

A_k = Cross-sectional area of the steel pipe

$$\Lambda = \sqrt{\pi^2 E / 0.6F}$$

In view of the effect of initial bend etc., this equation is based on a

safety factor of 2.17. This equation is appropriate for judgement because, according to a literature⁴), a safety factor of about 1.5 is enough to allow for the influence of an initial bend at a slope of 1/200.

4. APPLICATION TO ACTUAL BUILDINGS

The unbonded braces discussed here were used in No. 2 Nippon Steel Building (Shinkawa Building) constructed in Chuo-ku, Tokyo. The building is shown in Photo 3 and Fig. 18. The building with 15 stories above ground and 2 stories below intended as an office building consists essentially of a steel structure. Its typical floor, 20 m by 42 m in area, is of a single-core type, with three multi-storied earthquake-proof walls placed in the direction of the span of the core. Unbonded braces are used in them. Fig. 19 shows is a detailed cross section of the braces in place. In each layer, two braces are placed to form a V shape. By friction coupling with high-tension bolts, they are connected to the crossed gusset plates attached to an end and middle point of surrounding beams and columns. Reinforcement to prevent local buckling is provided to the beams and columns to which the gusset plates were attached.

The core members are all 250 mm by 25 mm in cross section, with their length made equal to that of the encasing steel pipe. Those used between the



Photo. 3 No. 2 Nippon Steel Building

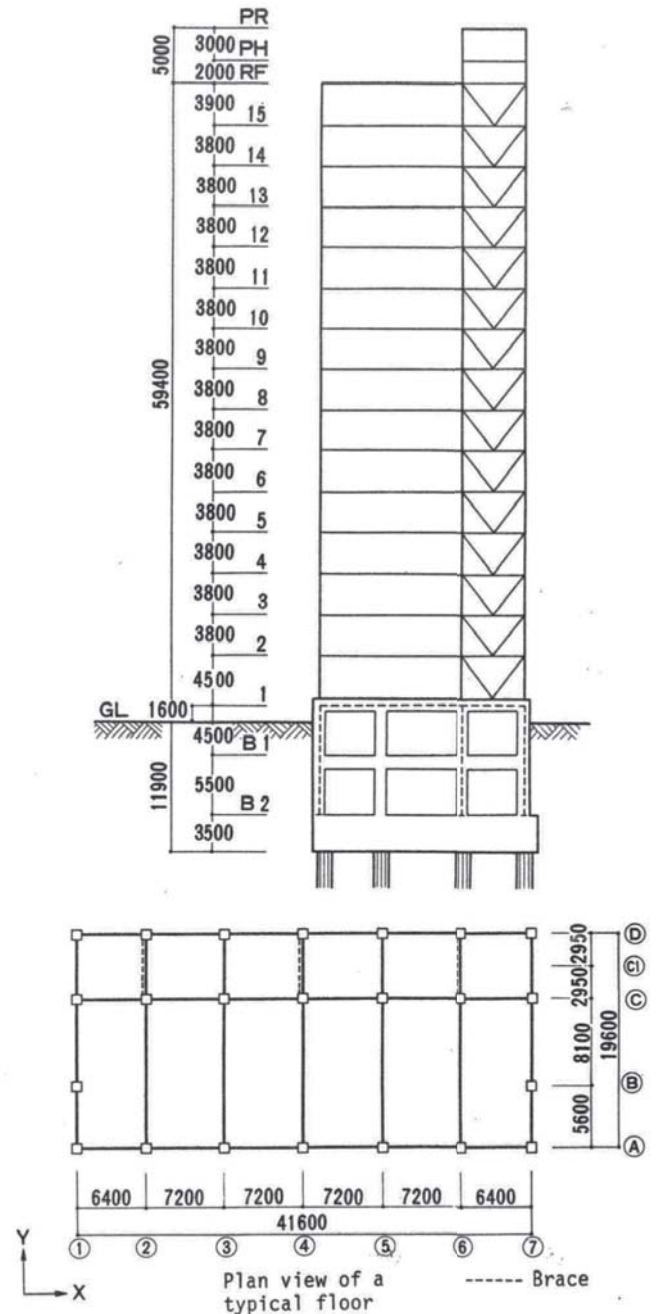

Name of Building:	No. 2 Nippon Steel Building
Location:	2-chome, Shinkawa, Chuo-ku, Tokyo
Owner:	Ogawa Unyu Co., Ltd.
Designed and supervised by:	Nippon Steel Corporation
Constructed by:	Nippon Steel Corporation
Construction Period:	February 1988 to November 1989
<Outline of Building>	
Site Area	: 4307 m ²
Building Area	: 1970 m ²
Total Floor Area:	26698 m ²

Fig. 18 No. 2 Nippon Steel Building (Frame structure)

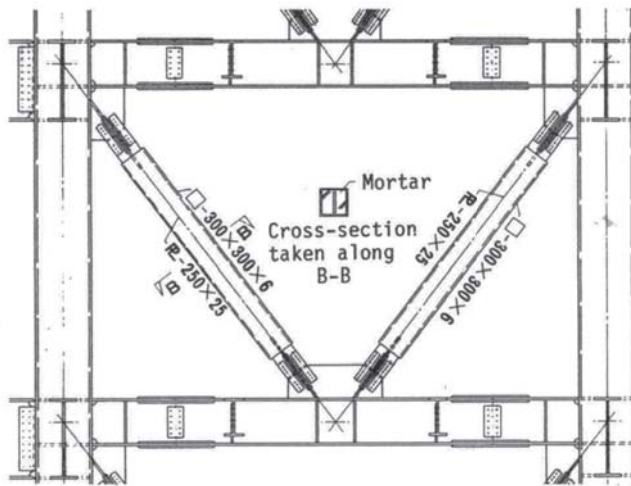

Fig. 19 Details of a brace

first and third floors are made of rolled steel for welded structure according to JIS G 3106, SM50 and those on the fourth floor and above are made of rolled steel for general structure according to JIS G 3101 SS41. This combination provides the yield strength conforming to the design shearing force. The most distinguishing feature of this brace is that it permits freely varying the rigidity and yield strength of the earthquake-proof wall by adjusting the cross-sectional area and yield point of the brace. This feature is very useful in controlling the natural period of a building and acquiring the desired yield strength. For convenience of manufacturing, the encasing steel pipes are 300 mm square in cross section (with a wall thickness of 6 mm), which is large enough to pass the reinforcing plate at each end of the core member. A large enough safety factor to cover the total buckling is derived from equation (3) as shown below:

$$N_u = 227 \text{ tons}$$

$$A_k = 57.6 \text{ cm}^2$$

$$\lambda = 26.9$$

$$\frac{0.277F}{(\lambda/\Lambda)^2} \bigg/ \frac{N_u}{A_k} = 3.35$$

Fig. 20 shows the maximum response shear stress of the building and the plasticity factor of its each floor at 50 kines. The members that become

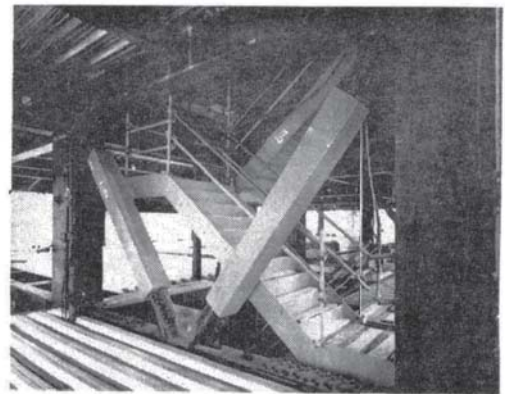

Photo. 4 Braces in place

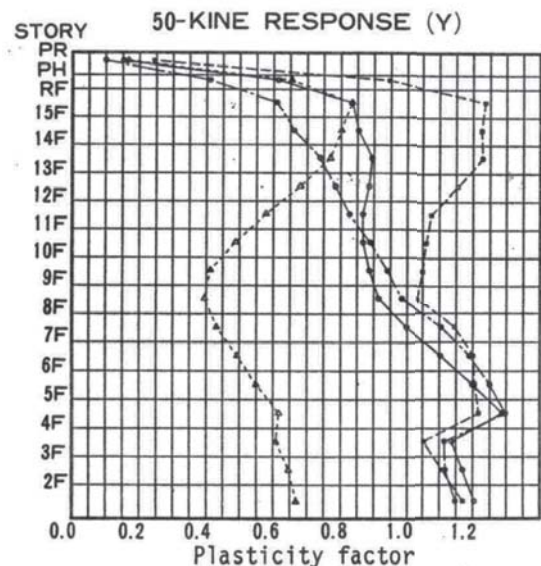
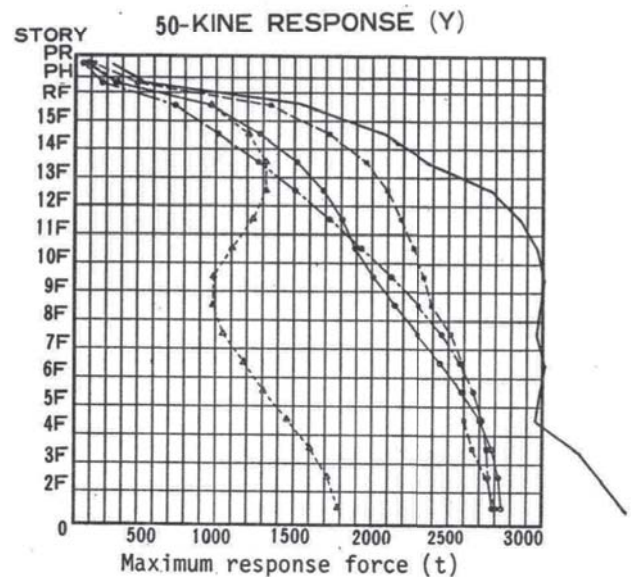

Fig. 20 Maximum response shearing force and plasticity factor

plastic first are the boundary beams between the rooftop and the fifth floor and the braces between the fourth and first floor. The maximum plasticity

factor of the yielding braces is approximately 1.25, which still leaves some margin compared with the results of the experiment discussed previously.

The braces were made by first preparing their core members and junctions, with a coating material applied on them. After fastening each core member in a square steel pipe erected upright, mortar was poured into the pipe. Erecting the pipe permitted securing firm mortar filling and helped prevent initial deflection to some extent.

Field installation was carried out in just the same way as with conventional braces. Offering no problem when installed according to the conventional method, the braces proved to have good workability. Before installing, a full-sized compression test was conducted to check their rigidity and yield strength. Fig. 21 shows the relation between the applied load and the deformation of the braces.

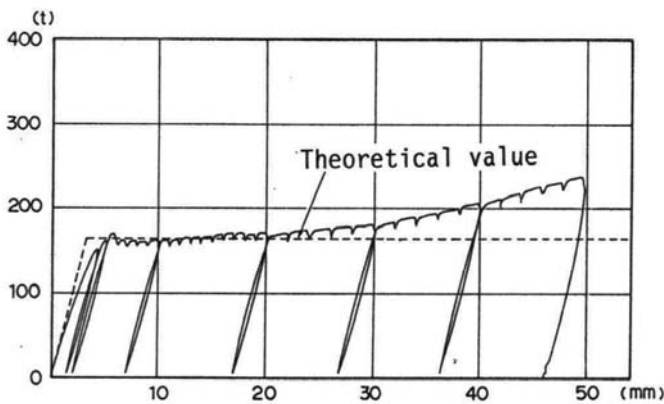

Fig. 21 Results of full-size compression test

5. APPLICATION OF SPECIAL STEELS

The greatest advantage of this brace is that it permits free control of the rigidity and yield strength of earthquake-proof walls. Therefore, its applicability can be expanded by preparing core members having wider variations of yield stress. Test was conducted to determine the hysteresis characteristics of core members of rolled steel for welded structure ac-

ording to JIS G 3105 SM58 whose yield point is higher than that of the JIS G 3101 SS41 and JIS G 3105 SM50 steels and extra-soft steel (SMIP) whose yield point is lower than that of the JIS G 3101 SS41 steel, as described below.

The test was made with type No. 1 specimens (consisting of a core member, 190 mm wide by 90 mm thick with a length equal to that of the encasing steel pipe whose cross section is 300 mm square) used in the fundamental experiment. The core members were made of the extra-soft, SS41 and SM58 steels. Table 2 shows their yield stresses determined by the test. The yield stress of the extra-soft steel was only about 38 percent of the SS41 steel's, whereas that of the SM58 steel was about 1.7 times as high. The steel pipes encasing core members of the three different types of steel were designed not to cause total buckling.

Table 2 Yield stress in material properties test

Specimen Designation	Material Steel	Yield Stress σ_y (t/cm ²)	Core Member	A* (cm ²)	P_y ** (t)	Dimension of Steel Pipe
S-28	Extra-soft Steel	0.92	PL-90 x 19	17.41	16.16	□-150 x 150 x 4.5 x 4.5 (SS41)
S-41	SS41	2.66		17.34	46.18	
S-58	SM58	4.87		17.36	84.61	

* Cross-sectional Area of Core Member
** Theoretical Yield Stress

Loads to cause a maximum deformation of 1/50 each time (1/75 for the SM58 steel because of the tester's limited capacity) were applied eight times, using the same tester as in the fundamental experiment.

Figs. 22 to 24 show their hysteresis curves. Obviously, they exhibited stable hysteresis characteristics, with symmetrically balanced tensile and compressive strengths. Their elasticity, rigidity and yield strength agreed well with theoretical values. All this proved that the advantages of the unbonded brace can be obtained with the extra-soft and SM58 steels, too.

At the same time, a dynamic repetitive loading test with a maximum loading speed of 25 cm/sec. and a fa-

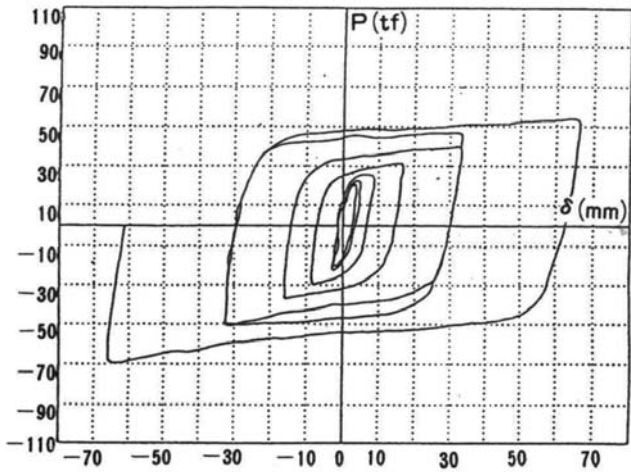

Fig. 22 Relationship between the axial force and axial displacement of a brace - S-28 (Extra soft steel)

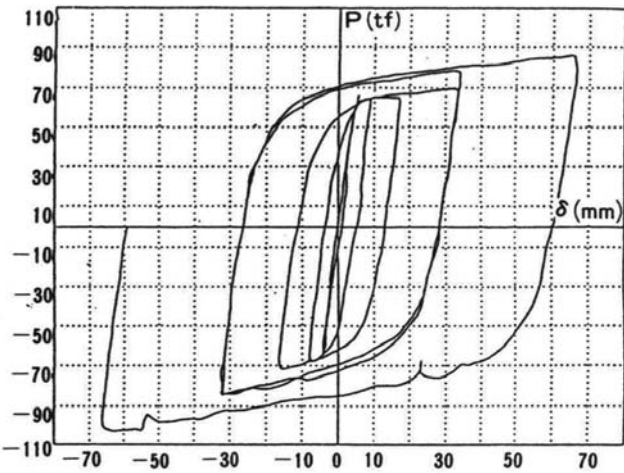

Fig. 23 Relationship between the axial force and axial displacement of a brace - S-41 (SS41 steel)

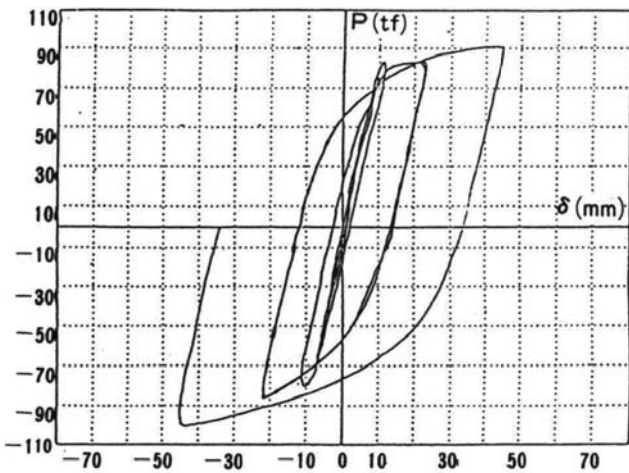

Fig. 24 Relationship between the axial force and axial displacement of a brace - S-58 (SM58 steel)

tigue test to apply an allowable stress over a long time (10,000 times) were given to the specimen with the SS41 steel core member. Figs. 25 and 26 respectively show the hysteresis characteristics under dynamic loading and the results of the long-time fatigue test. The hysteresis characteristics under dynamic loading proved to be as stable as under static loading. The unbonded braces thus proved to function properly in masses, under dynamic loading and even after fatigue.

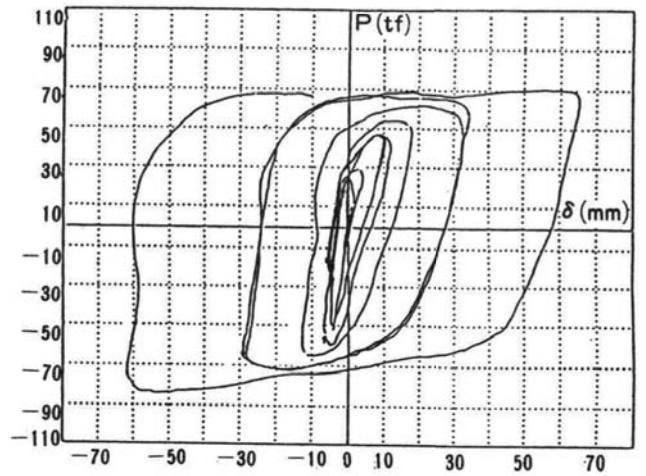

Fig. 25 Relationship between the axial force and axial displacement of a brace D-41 (SS41 steel under dynamic loading)

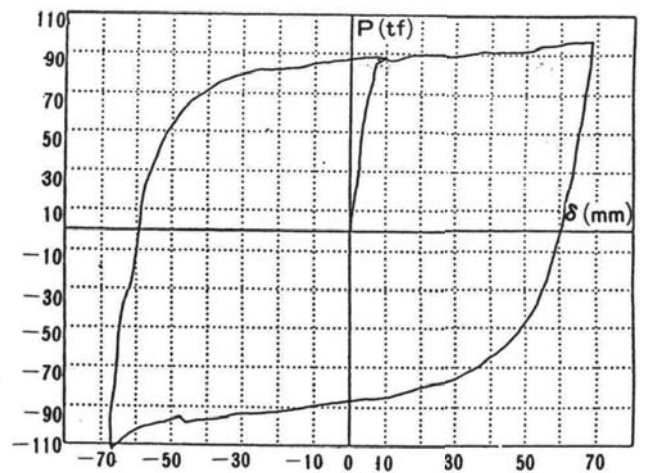

Fig. 26 Relationship between the axial force and axial displacement of a brace - S41 (SS41 steel loaded after fatigue test)

6. PROPOSAL OF NEW FRAME DESIGN

The unbuckling unbonded braces can be used not only as earthquake-proof walls of the conventional type but also in other new ways. Some examples of such new applications will be given in the following.

6.1 All-Brace Structure

High-rise buildings largely based on braces, such as those mentioned at the beginning, are popular in many countries but have not been built in Japan because their rigidity is not high enough for an earthquake-ridden country. But the unbonded braces with stable hysteresis characteristics permit building such structures even in Japan. They not only increase the

freedom in the design of high-rise buildings but also permits economical designs because rigidity of buildings can be secured more effectively than before.

Figs. 27 and 28 show two models of 40-storied office buildings trially designed with a structure comprising conventional multi-storied earthquake-proof walls and one fully surrounded with braces. By assuming an earthquake of 25 kines maximum, vibrations of the two models were analyzed. Based on the results of the analysis, design was made to keep the maximum inter-floor deformation below 1/200. Also, the stresses to which the individual members are to be subjected were kept below 0.9 times their allowable stresses.

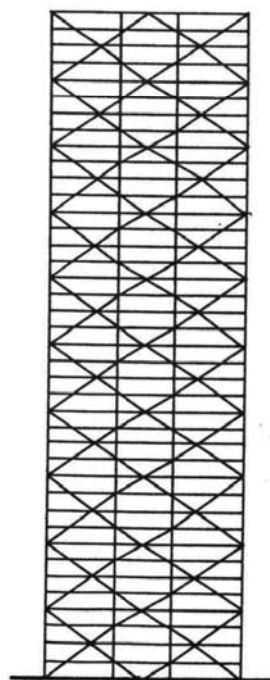
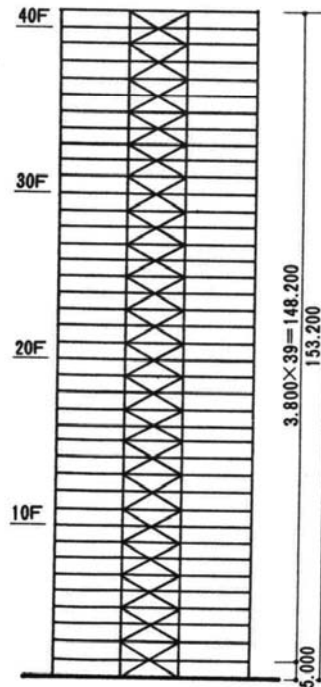
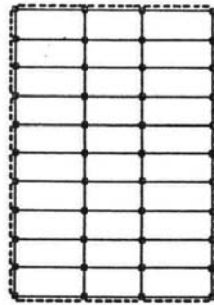
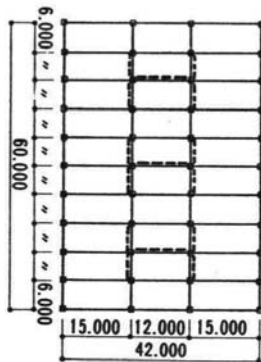

Fig. 27 Frame structure with multi-storied earthquake-proof walls

Fig. 28 Frame structure fully enclosed with braces

Table 3 shows the cross sections of the main structural members of the two models. The columns and beams of the fully braced model fully are one-size smaller than those of the model with conventional multi-storied earthquake-proof walls. This is because the surrounding braces provide adequate rigidity and shear strength, thereby

Table 3 Cross sections of main member and steel requirements (Frame structure with multi-floored earthquake-proof walls and fully braced frame structure)

Frame Structure with Multi-floored Earthquake-proof Walls			
	Column	Beam	Brace (Core Member)
40F	□-600x600x28x28	H-850x300x14x32	+250x250x ③ x ③
30F	□-600x600x50x50	H-850x300x14x32	+250x250x ③ x ③
20F	□-600x600x50x50	H-850x300x14x32	+250x250x ③ x ③
10F	□-600x600x65x65	H-850x300x16x32	+250x250x ③ x ③
1F	□-600x600x80x80	H-850x300x16x32	+250x250x ③ x ③
Steel Requirement	15,258 t (152 kg/m ²)		
Fully Braced Frame Structure			
	Column	Beam	Brace (Core Member)
40F	□-600x600x22x22	H-850x300x14x28	+250x250x ② x ②
30F	□-600x600x36x36	H-850x300x14x28	+250x250x25x25
20F	□-600x600x45x45	H-850x300x14x28	+250x250x25x25
10F	□-600x600x55x55	H-850x300x16x32	+250x250x25x25
1F	□-600x600x70x70	H-850x300x16x32	+250x250x ② x ②
Steel Requirement	13,504 t (134 kg/m ²)		

(Unmarked = SM50 steel, circled = S541 steel, and squared = SM58 steel)

decreasing the burden on the inner columns and beams. The cross section of the braces too is smaller in the fully braced model, whose structural steel requirement proves to be approximately 10 percent smaller.

The ratio of shearing force born by the braces is 25 to 50 percent in the model with multi-storied earthquake-proof walls and 40 to 60 percent in the fully braced model. The cycle of stress, approximately 4.3 seconds, is normal for the height of the model.

In fully braced structures, care should be taken against the pull-out of corner columns on the primary level. But this problem can be overcome by dividing the self weight of the building among its corner columns, as done with the Bank of China building in Hongkong, or by providing basements of appropriate depth.

The comparison discussed here was made between models of 40-storied buildings. With higher buildings, multi-storied earthquake walls will not be able to provide the required rigidity. Then, the advantage of the fully braced structure will become decided. When combined with recently developed fire-resistant steels, facades of more novel designs, such as those with exposed structural members, may become possible.

6.2 Hinged Megastructure

The new buildings for the Tokyo Metropolitan Government Office and Nippon Electric Co., Ltd.'s head office are based on megastructures. Their stable ability to absorb seismic energy is secured by allowing the boundary beams surrounded with built-up columns and trussed beams to yield first.

Even so, there is a danger that buckling will eventually occur where the built-up columns and trussed beams are joined together, as with the multi-storied earthquake walls made of ordinary braces. But unbonded braces used as chord members at the ends of trussed beams will serve as stable hinges that will make it no longer necessary for

the boundary beams to absorb seismic energy. Provision of such hinges will permit free designs, such as those with floors suspended from a mega-frame, those with openings to pass elevated roads or railways through their walls, and those with elevated gardens. Fig. 29 shows a model with five mass points of a 40-storied office building with trussed beams provided every eight floors. In its design, the mega-frame was replaced with an assembly of structural members having equivalent rigidity, with consideration given to deformation under shearing and bending stresses. Vibrations of the building was analyzed by assuming that the mass points of the eight floors concentrated on the trussed beams. Then, the individual members were designed to ensure that the inter-floor deformation would be held below 1/200 at 25 kines and below 1/100 at 50 kines. The inter-floor deformation of other members than those used as hinges was held within the limit of their elasticity.

Table 4 shows the cross sections of the main structural members. Obviously, the unbonded chord members are required to have a cross sectional area of 500 cm² to 1000 cm², with a yield stress of approximately 1.5 tons/cm². Therefore, the core members of this building will have to be made of mild steel. The steel requirement per unit area, 207 kg/m², is normal for this type of buildings.

Unbonded braces can also be used in the construction of large-span structures. Large-span structures made up of trussed members, such as artificial foundations, contain some members, such as capitals to support roof trusses, that might buckle when subjected to horizontal forces. The use of unbonded braces as such critical compression members assures safety against severe earthquakes (see Fig. 31).

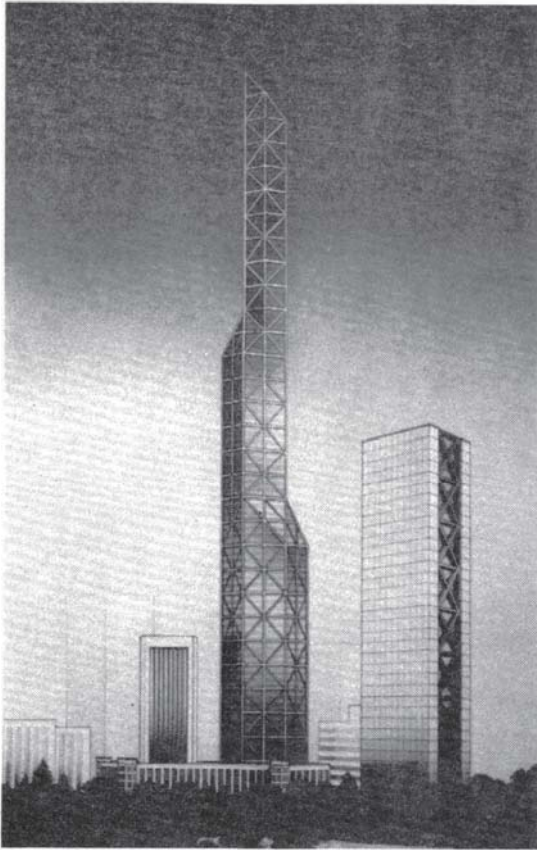

Fig. 29 Super-high-rise building with fully braced frame structure

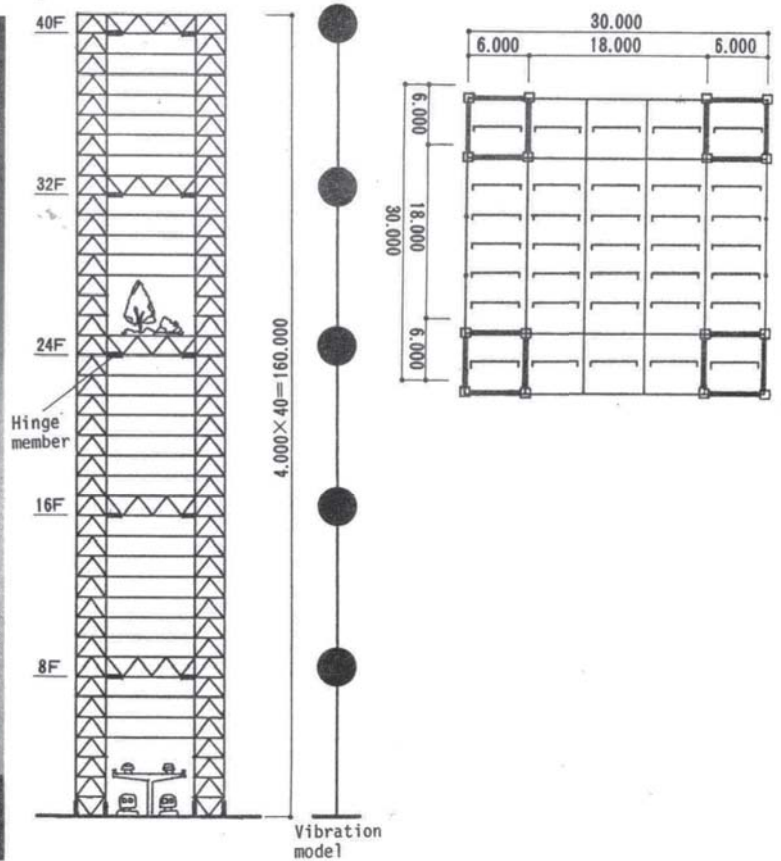

Fig. 30 Megastructure building frame

Table 4 Cross sections of main members and steel requirements (Mega-frame structure)

F1.	Structural Member	Column	Beam	Hinge (Core Member)
33	Chord Member	H-600x600x32x32	H-600x600x28x28	■-220x220* (A = 488 cm ²)
	Diagonal Member	H-300x300x19x19	H-350x350x25x25	
25	Chord Member	H-600x600x55x55	H-600x600x45x45	■-277x277* (A = 770 cm ²)
	Diagonal Member	H-300x300x19x19	H-350x350x36x36	
17	Chord Member	H-600x600x70x70	H-600x600x55x55	■-305x305* (A = 930 cm ²)
	Diagonal Member	H-300x300x19x19	H-350x350x40x40	
9	Chord Member	H-600x600x80x80	H-600x600x60x60	■-317x317* (A = 1008 cm ²)
	Diagonal Member	H-300x300x25x25	H-350x350x40x40	
1	Chord Member	H-600x600x85x85	H-600x600x80x80	■-362x362* (A = 1312 cm ²)
	Diagonal Member	H-300x300x25x25	H-350x350x45x45	
Steel Requirement		7,382 t (207 kg/m ²)		

(Unmarked = SM50 steel, * = Extra-soft steel)

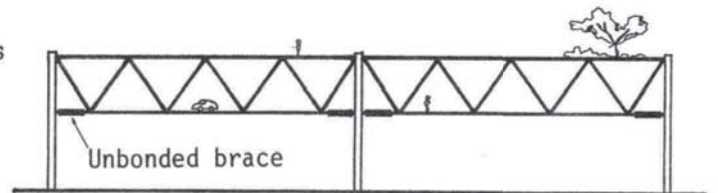

Fig. 31 Application of unbonded braces to artificial foundation

7. CONCLUSION

As will be obvious from the above, the unbonded braces born of quite a simple idea have many excellent features such as high dynamic stability and ease of modeling, design and construction. Their wide applicability to various types of structures opens up the possibility of creating absolutely new forms of structures. It is our hope that this brief introduction of their excellent features will add valuable contribution to the design of urban buildings that are growing higher and more original.

The authors wish to express appreciation to the guidance and assistance offered by Messrs. Morihisa Fujimoto (Professor of Kanagawa University) and Tadao Nakagome (Assistant Professor of Shinshu University) in conducting experiments.

Akira Wada: Professor of Tokyo Institute of Technology

Eiichiro Saeki, Tohru Takeuchi and Atsuchi Watanabe: Staff Members of the Building Construction Division of Nippon Steel Corporation

REFERENCES

- 1) Y. Takeda, Y. Kimura, K. Yoshioka, N. Furuya and Y. Takemotô : An Experimental Study on Braces encased in Steel Tube and Mortar, Annual Meeting Architectural Institute of Japan, Oct. 1976, pp. 1041-1042, in Japanese
- 2) Y. Murata, S. Mochizuki, N. Andou, S. Takahashi : An Experimental Study on Buckling of Unbonded Braces Under Centrally Applied Loads, Annual Meeting Architectural Institute of Japan, Sep. 1980, pp. 1913-1914, in Japanese
- 3) M. Fujimoto, A. Wada, E. Saeki, Y. Hitomi, A. Watanabe : Properties of Brace Encased in Buckling-Restraining Concrete and Steel Tube, Ninth World Conference on Earthquake Engineering August 1988, Tokyo-Kyoto, Vol. IV, pp. 719-723