

論文 / 著書情報
Article / Book Information

題目(和文)	
Title(English)	A study on fundamental properties of representations for piecewise linear functions
著者(和文)	櫻井智章
Author(English)	tomoaki sakurai
出典(和文)	学位:博士(理学), 学位授与機関:東京工業大学, 報告番号:甲第9681号, 授与年月日:2014年12月31日, 学位の種別:課程博士, 審査員:室伏 俊明,出口 弘,廣田 薫,渡邊 澄夫,石井 秀明
Citation(English)	Degree:., Conferring organization: Tokyo Institute of Technology, Report number:甲第9681号, Conferred date:2014/12/31, Degree Type:Course doctor, Examiner:,,,,,
学位種別(和文)	博士論文
Type(English)	Doctoral Thesis

A study on fundamental properties of
representations for piecewise linear
functions

Tomoaki Sakurai

February 24, 2014

Contents

1	Introduction	1
1.1	Background	1
1.2	Objectives of this thesis	4
1.3	Notation	5
2	Representations of piecewise linear function	6
2.1	Piecewise linear function	6
2.2	Chua canonical form	7
2.3	Linear complementarity representation	10
2.4	Max-min polynomial	11
3	The Choquet integral as a piecewise linear function	14
3.1	Definition and fundamental properties	15
3.2	Chua canonical form of Choquet integral	16
3.3	Linear complementarity representation of Choquet integral	17
3.4	Max-min polynomial of Choquet integral	19
3.5	Summary	20
4	The linear complementarity representation	21
4.1	P-representation and ULT-representation	21
4.2	Operations on ULT	22
4.3	Coincidence of P , ULT , and PWL	24
4.4	Construction of ULT-representation	25
4.5	Transforming a representation: from P to ULT	26
4.6	Summary	30

5	Minimization of the linear complementarity representation	32
5.1	Problem formulation	32
5.2	General consideration	33
5.2.1	Reducibility of the complementarity vectors	34
5.2.2	ULT-reducibility	35
5.3	Geometry of the complementarity vectors	37
5.4	Difference between the P-minimization and the ULT-minimization	41
5.5	Summary	42
6	Conclusion	44
A	Fundamentals	50
A.1	Convex analysis essence	50
A.2	The linear complementarity problem	51
A.3	Complementarity cone	52
A.4	Nowhere density in \mathbb{R}^n	54
B	Proofs	55
B.1	Proof of Theorem 2.1	55
B.2	Proof of Theorem 3.2	56
B.3	Proof of Theorem 4.2	59
B.4	Proof of Theorem 5.2	61
B.5	Proof of Theorem 5.3	62
B.6	Proof of Theorem 5.4	62
C	High-level canonical form of Choquet integral	64
D	Construction of max-min polynomial	66
D.1	Construction procedure	66
D.2	Examples	67

Chapter 1

Introduction

Owing to an ability of uniformly approximating a continuous function defined on a compact domain, and a property of linearity on a neighbourhood of almost every point in the domain, piecewise linear function plays an important role as an approximation function in many fields such as non-linear circuit [5], non-linear control [15, 29, 41], analysis of various complex systems [18], computer graphics, calculation of the equilibrium points arising from operations research [1, 2], combinatorial topology [4], and so on. Most commonly used method of approximating complex nonlinear behavior is the method called spline function method. Piecewise linear function is often called first-order spline function [42]. Nowadays, a lot of analytical techniques, as well as representations, for piecewise linear functions have been developed by many researchers in order to analyze any nonlinear behaviors. The objective of our study is to contribute to the development of fundamental theory of piecewise linear functions through the promotion of mutual use of these techniques. This thesis aims to present our study on fundamental properties of representations for piecewise linear functions achieved so far as a preliminary study for this purpose.

1.1 Background

Limitation of piecewise linear function: As explained at the beginning of this chapter, owing to its high versatility, piecewise linear function has widely been used in many fields. However, it also presents some problems in practical use: Improving an approximation in accuracy causes the exponential increase of the number of parameters; it is not so easy to treat the expression of piecewise linear functions based on its definition. Consequently, many researchers have made an effort to develop efficient and versatile representations of piecewise linear functions. Representations developed so far are roughly

divided into the following three types:

- (i) Absolute-value sign representation like Chua canonical form.
- (ii) Implicit representation like the linear complementarity representation.
- (iii) Boolean representation like the max-min polynomial.

Although it has not necessarily been established itself the position as one of the representations for piecewise linear functions, the Choquet integral, defined by non-additive measure, has turned out to be closely related to piecewise linear function, and therefore has attracted attention from several researchers in recent years.

Development of an efficient and versatile representation – Chua canonical form and its generalization: Chua et al. [7] have introduced a compact representation of piecewise linear function, called Chua canonical form, in their attempt to overcome the afore mentioned problem. Their representation is often referred to as Chua1 in literature. In 1988, Chua et al. [8] showed the limitation of their representation, much research has been done in an effort to develop new efficient representations that is an extension of Chua1 or an alternative one. See [16, 21] for more details of historical background on their developments. Although the investigation on its generalization has not been done at the present, Chua canonical form still have often been used in the development of non-linear circuits. See Section 2.2 for the definition of Chua canonical form and its properties.

Development of an efficient and versatile representation – Linear complementarity representation: In 1981, van Bokhoven et al. have introduced another type of representation referred to as Bokh1 model, in literature, to develop a piecewise linear simulator for non-linear circuit and network (see e.g., [5, 10, 21] for detail). Some researchers refer Bokh1 model to state-variable representation, but we dub it “linear complementarity representation” in order not to confuse it with “state space model” in dynamical system theory (see also Remark 2.7 in Section 2.3). Bokh1 differ significantly from Chua1 because it contains inner-variables called “the complementarity vectors”. So this model belongs to the type of implicit representations. By the way, since Bokh1 has considerable advantages as mentioned in Section 2.3, this model has attracted a significant amount of attention from other fields of engineering as well as circuit theory (e.g., [13, 14, 15, 33, 34]). However, the study on fundamental properties of this model has not been performed enough. Therefore, we have been motivated by such situation, and hence, in our study, we will aim to contribute to clarify its fundamental properties.

Development of an efficient and versatile representation – Max-min polynomial: There is another type of efficient representation called max-min polynomial. The studies on this representation have widely been done from practical and theoretical points of view. Tarela et al. [37, 38, 39] have introduced this model to develop a model of analog diode logic simulators. Aliprantis et al. [1] have studied on this model to calculate various equilibrium points arising from operations research concerning to economic theory. Moreover, it is well known that this model can cover all piecewise linear functions [11, 28, 39], and so far a method of constructing a max-min polynomial for a given piecewise linear function has also been provided [1, 28, 39]. On the other hand, the problem of reducibility for a given max-min polynomial has implicitly been pointed out in [1, 28]. In addition, Tarela et al. [39] have discussed the reducibility in a certain situation. However, the method of constructing a complete irreducible representation still have not been developed yet. This motivates us to study the reducibility of max-min polynomial. The problem is not discussed in this thesis, however, this representation plays an important role in our study on the linear complementarity representation.

Multi-step Choquet integral over a finite set: The multi-step Choquet integral is defined recursively from the (one-step) Choquet integral, where the Choquet integral is one of the models used in the area of decision making as an aggregation function, and owing to its high versatility compared with the usual linear model, it has widely been investigated by a lot of researchers in theoretical and practical points of view (see e.g., [12]). In 2002, Murofushi and Narukawa showed that piecewise linear function is characterized by multi-step Choquet integral over a finite set [24, 26]. This result suggests that the Choquet integral becomes another type of representation for piecewise linear functions, and would provide various useful analytical techniques for the area of piecewise linear functions and vice versa.

Mutual transformation: In generally, analytical techniques depend on how we model the object. Since each representation has its own advantages over the others, we expect to obtain significantly useful analytical benefits through mutual uses of these techniques. For this purpose, we need to clarify the mutual relationships among the representations. To this point, several researchers have already implemented the survey concerning to mutual transformations motivated by such intention: van Bokhoven et al. have investigated two special types of Bokh1 in order to extend Chual model, and developed a method of

transforming an implicit representation to an absolute-value sign representation [3, 19, 20]. Heemels et al. [13] have studied the relationships among five classes of representations involving the piecewise linear model in hybrid dynamical system theory, and provided the mutual transformation among them. In addition, based on this study, Cairano et al. [6] have also investigated the relationship between the piecewise linear model and the another model. On the other hand, as mentioned above, since the multi-step Choquet integral characterizes all piecewise linear functions, the establishment of mutual transformation with the multi-step Choquet integral would provide us numerous significance. This motivates us to investigate the Choquet integral as a piecewise linear function.

1.2 Objectives of this thesis

This thesis will present the following three contents obtained in our study:

Relationships and mutual transformations among representations: We clarify the relationships among the representations of piecewise linear functions, Chua canonical form, the linear complementarity representation, the max-min polynomial, and the Choquet integral as a piecewise linear function.

Fundamental properties of the linear complementarity representation: We investigate the linear complementarity representation to refine the result of Heemels et al. [13], namely, the representability of all piecewise linear functions (Theorem 2.2 in Section 2.3). Precisely speaking, we clarify that two special types of linear complementarity representation, called the P-representation and the ULT-representation, introduced in [19, 20], individually characterizes any piecewise linear function. For this purpose, we study their fundamental properties. Moreover, we provide a construction method of a ULT-representation for a given piecewise linear function. We also present a transformation method of each P-representation to a ULT-representation.

Minimization of the linear complementarity representation: The other interest on this model is the minimization of the number of parameters. As demonstrated in Section 4.4, the dimension of the complementarity vectors is not uniquely determined. In other words, we can select the dimension of the complementarity vectors as large as possible. This means the existence of the representation having a minimum dimensional complementarity vectors. In practically, it would be desirable to achieve the dimension as small as possible. In our study, the problem of finding a minimum dimensional repre-

sentation is discussed.

This thesis is organized as follows: Chapter 2 will be devoted to the exposition for the representations of piecewise linear function. The representations what we deal with, in this thesis, are Chua canonical form, the linear complementarity representation, and the max-min polynomial. In Chapter 3, we will investigate the Choquet integral as a piecewise linear function. The investigation focuses on the relation between the Choquet integral and the representations introduced in Chapter 2. In Chapter 4, we will describe our first part of the investigation on the linear complementarity representation. In Chapter 5, we will discuss the problem of minimization of the linear complementarity representation. Chapter 6 is devoted to the conclusion of this thesis. Appendix A–D describe the supplements of this thesis.

1.3 Notation

Throughout this thesis, m and n indicate positive integers. Unless otherwise noted, k is a nonnegative integer. For a positive integer l , the set of integers from 1 to l is denoted by $[l]$, i.e., $[l] = \{1, 2, \dots, l\}$. The max and min operators are denoted by \vee and \wedge , respectively. For $x \in \mathbb{R}$ we write $x^+ = x \vee 0$ and $x^- = (-x)^+$. Moreover, $\lceil x \rceil$ denotes the smallest integer greater than or equal to x . The inner product of two vectors $\mathbf{x}, \mathbf{y} \in \mathbb{R}^n$ is denoted by $\langle \mathbf{x}, \mathbf{y} \rangle$. Topological interior and topological closure of a set A are denoted by $\text{int } A$ and $\text{cl } A$ respectively. “Linear” should be read as “affine linear” in this thesis.

Chapter 2

Representations of piecewise linear function

In this chapter, we introduce representations of piecewise linear functions dealt with this thesis except for the Choquet integral, and describe their fundamental properties. Section 2.1 defines the piecewise linear function. Sections 2.2 to 2.4 introduces representations of piecewise linear functions. Chua canonical form (Section 2.2), the linear complementarity representation (Section 2.3), and the max-min polynomial (Section 2.4), and mentions about their known results.

2.1 Piecewise linear function

A convex set $R \subset \mathbb{R}^n$ is called a polyhedron if it can be represented as the intersection of finitely many closed half-spaces in \mathbb{R}^n , i.e., if $R = \bigcap_{i=1}^r \{\mathbf{x} \in \mathbb{R}^n \mid \langle \mathbf{a}_i, \mathbf{x} \rangle \leq \alpha_i\}$, where r is a nonnegative integer; $\mathbf{a}_i \in \mathbb{R}^n$ and $\alpha_i \in \mathbb{R}$ for $i \in [r]$. By definition, \emptyset and \mathbb{R}^n are polyhedra.

Definition 2.1. (See e.g., [11]) A finite family \mathcal{R} of polyhedra in \mathbb{R}^n is called a *polyhedral partition* of \mathbb{R}^n if it satisfies the following:

- (i) $\bigcup \mathcal{R} = \mathbb{R}^n$;
- (ii) $\text{int } P \neq \emptyset$ for all $P \in \mathcal{R}$;
- (iii) For each $P, Q \in \mathcal{R}$, $P \neq Q$ implies $\text{int } P \cap \text{int } Q = \emptyset$,

Definition 2.2. (See e.g., [11, 28]) A function $f : \mathbb{R}^n \rightarrow \mathbb{R}^m$ is said to be *piecewise linear* if it is continuous on \mathbb{R}^n and there exists a polyhedral partition \mathcal{R} of \mathbb{R}^n such that f is linear on each region $R \in \mathcal{R}$. A linear function $g : \mathbb{R}^n \rightarrow \mathbb{R}^m$ which coincides

with f on some $R \in \mathcal{R}$ is said to be a linear component of f . We define the family $\text{PWL} = \{f : \mathbb{R}^n \rightarrow \mathbb{R}^m \mid f \text{ is piecewise linear, } m \in \mathbb{N}\}$.

2.2 Chua canonical form

We begin with another definition of piecewise linear function given by Chua et al. [8] for the simplicity of our argument in this thesis.

Definition 2.3. [8] A finite collection $\{(\boldsymbol{\alpha}_i; \beta_i)\}_{i=1}^l$ of pair of a vector $\boldsymbol{\alpha}_i \in \mathbb{R}^n \setminus \{\mathbf{0}\}$ and a scalar $\beta_i \in \mathbb{R}$ is called a *linear partition* of \mathbb{R}^n if it satisfies the following:

(lp) if $i \neq j$, there is no $\lambda \in \mathbb{R}$ such that $\lambda\boldsymbol{\alpha}_i = \boldsymbol{\alpha}_j$ and $\lambda\beta_i = \beta_j$.

Each $(\boldsymbol{\alpha}_i; \beta_i)$ is called a *boundary hyperplane*. The *family of regions* generated by a linear partition $\{(\boldsymbol{\alpha}_i; \beta_i)\}_{i=1}^l$ of \mathbb{R}^n is the family \mathcal{R} of subsets of \mathbb{R}^n defined as $\mathcal{R} = \{R_I \mid I \subset [l], \dim(R_I) = n\}$, where

$$R_I = \left\{ \mathbf{x} \in \mathbb{R}^n \mid \begin{array}{l} \langle \boldsymbol{\alpha}_i, \mathbf{x} \rangle \geq \beta_i \text{ for all } i \in I, \\ \langle \boldsymbol{\alpha}_i, \mathbf{x} \rangle \leq \beta_i \text{ for all } i \notin I \end{array} \right\}.$$

Remark 2.1. Notice that \mathcal{R} is a polyhedral partition of \mathbb{R}^n in the sense of Definition 2.1 (See Appendix B.1).

Definition 2.4. [8] Let $\{(\boldsymbol{\alpha}_i; \beta_i)\}_{i=1}^l$ be a linear partition of \mathbb{R}^n and \mathcal{R} be the family of regions generated by $\{(\boldsymbol{\alpha}_i; \beta_i)\}_{i=1}^l$. Two regions $R_I, R_J \in \mathcal{R}$ are called (*i*-)neighbors if $I \Delta J = \{i\}$ holds.

Definition 2.5. [8] A function $f : \mathbb{R}^n \rightarrow \mathbb{R}^m$ is called a *piecewise-linear* if there exists a linear partition $\{(\boldsymbol{\alpha}_i; \beta_i)\}_{i=1}^l$ of \mathbb{R}^n satisfying the following:

(pwl) For every $R \in \mathcal{R}$, there exist a matrix $A \in \mathbb{R}^{m \times n}$ and a vector $\mathbf{b} \in \mathbb{R}^m$ such that

$$f(\mathbf{x}) = A\mathbf{x} + \mathbf{b}, \quad \text{for any } \mathbf{x} \in R.$$

Remark 2.2. Every piecewise linear function has infinitely many linear partition of \mathbb{R}^n satisfying the condition (pwl).

The next theorem indicates that two definitions of piecewise linear function are equivalent to each other.

Theorem 2.1. A function $f : \mathbb{R}^n \rightarrow \mathbb{R}^m$ is piecewise linear according to Definition 2.2 if and only if it is piecewise linear according to Definition 2.5

Proof. See Appendix B.1. □

We are now ready to explain Chua canonical form.

Definition 2.6. [7, 8] A piecewise linear function $f : \mathbb{R}^n \rightarrow \mathbb{R}^m$ possesses a *Chua canonical form* if f can be expressed as

$$f(\mathbf{x}) = \mathbf{a} + B\mathbf{x} + \frac{1}{2} \sum_{i=1}^k \mathbf{c}_i |\langle \boldsymbol{\alpha}_i, \mathbf{x} \rangle - \beta_i|, \quad (2.1)$$

where k is a nonnegative integer, $B \in \mathbb{R}^{m \times n}$, $\boldsymbol{\alpha}_i \in \mathbb{R}^n \setminus \{\mathbf{0}\}$, $\mathbf{a} \in \mathbb{R}^m$, $\mathbf{c}_i \in \mathbb{R}^m \setminus \{\mathbf{0}\}$, $\beta_i \in \mathbb{R}$ ($i = 1, 2, \dots, k$), and $\{(\boldsymbol{\alpha}_i; \beta_i)\}_{i=1}^k$ satisfies (lp).

Remark 2.3. Chua canonical form is unique in the sense that, if a piecewise linear function (2.1) is represented as

$$f(\mathbf{x}) = \mathbf{a}' + B'\mathbf{x} + \frac{1}{2} \sum_{i=1}^{k'} \mathbf{c}'_i |\langle \boldsymbol{\alpha}'_i, \mathbf{x} \rangle - \beta'_i|, \quad (2.1')$$

then $\mathbf{a} = \mathbf{a}'$, $B = B'$, $k = k'$ and there exist a bijection $\pi : [k] \rightarrow [k]$ and positive numbers $\gamma_1, \gamma_2, \dots, \gamma_k$ such that for every $i \in [k]$

$$\mathbf{c}_i = \gamma_i \mathbf{c}'_{\pi(i)}, \quad \boldsymbol{\alpha}_i = \gamma_i^{-1} \boldsymbol{\alpha}'_{\pi(i)}, \quad \beta_i = \gamma_i^{-1} \beta'_{\pi(i)}.$$

Based on the observation above, throughout the thesis we put on Chua canonical form (2.1) the constraint that $\|\boldsymbol{\alpha}_i\|_\infty = \|(\alpha_{i1}, \alpha_{i2}, \dots, \alpha_{in})\|_\infty = \sup_{j=1,2,\dots,n} |\alpha_{ij}| = 1$ for $i = 1, 2, \dots, k$.

Besides the uniqueness, Chua canonical form has remarkable advantages such as a concise expression, a small number of parameters, and the explicit information on a linear partition of f , which is given as $\{(\boldsymbol{\alpha}_i; \beta_i)\}_{i=1}^k$ by $\boldsymbol{\alpha}_i$'s and β_i 's in (2.1).

Next, we explain the condition for a piecewise linear function to have Chua canonical form.

Definition 2.7. [8] Let $f : \mathbb{R}^n \rightarrow \mathbb{R}^m$ be a piecewise linear function, then f is said to possess the *consistent variation property* if there exists a linear partition $\{(\boldsymbol{\alpha}_i; \beta_i)\}_{i=1}^k$ of \mathbb{R}^n satisfying the following:

(cv) For every boundary hyperplane $(\boldsymbol{\alpha}_i; \beta_i)$, there exists a matrix $C_i \in \mathbb{R}^{m \times n}$ such that, for every pair of i -neighboring regions (R_{iI}^+, R_{iI}^-) , it holds that

$$A_{iI}^+ - A_{iI}^- = C_i,$$

where A_{iI}^+ and A_{iI}^- are the Jacobians on R_{iI}^+ and R_{iI}^- , respectively,

$$R_{iI}^+ = \left\{ \mathbf{x} \in \mathbb{R}^n \mid \begin{array}{l} \langle \boldsymbol{\alpha}_l, \mathbf{x} \rangle \geq \beta_l \text{ for all } l \in I \cup \{i\}, \\ \langle \boldsymbol{\alpha}_l, \mathbf{x} \rangle \leq \beta_l \text{ for all } l \notin I \cup \{i\} \end{array} \right\},$$

$$R_{iI}^- = \left\{ \mathbf{x} \in \mathbb{R}^n \mid \begin{array}{l} \langle \boldsymbol{\alpha}_l, \mathbf{x} \rangle \geq \beta_l \text{ for all } l \in I, \\ \langle \boldsymbol{\alpha}_l, \mathbf{x} \rangle \leq \beta_l \text{ for all } l \notin I \end{array} \right\},$$

and $I \subset \{1, 2, \dots, k\} \setminus \{i\}$.

Remark 2.4. $\mathbf{c}_i |\langle \boldsymbol{\alpha}_i, \mathbf{x} \rangle - \beta_i|$ in (2.1) expresses the change of the linear component of f when crossing over the boundary hyperplane $(\boldsymbol{\alpha}_i; \beta_i)$. The condition (cv) requires that this change is constant independent of the crossing point. Moreover, there exists a unique vector $\mathbf{c}_i \in \mathbb{R}^m$ such that $C_i = \mathbf{c}_i \boldsymbol{\alpha}_i^T$. The coefficient \mathbf{c}_i coincides with the constant vector \mathbf{c}_i in the right-hand side of (2.1).

Proposition 2.1. [8] *A piecewise linear function $f : \mathbb{R}^n \rightarrow \mathbb{R}^m$ possesses Chua canonical form if and only if f possesses the consistent variation property.*

As explained in Remark 2.4, the condition (cv) is very strong, and therefore a lot of functions can not be expressed as Chua canonical form. Since then many researches have been done in an effort to generalize Chua canonical form (see [3, 16, 17, 19, 20, 21, 22, 40]). Most of researches have adopted the methodology that restricts functional form or domain partition to be a certain form, and have investigated the condition for a piecewise linear function to have such formulas. On the other hand, the study given by Lin et al. [22] has focused on the nesting level of the absolute value sign, and then clarified that every piecewise linear function can be expressed in a kind of canonical form of some nesting level. The result has not provided the method of generating a concrete expression for a given piecewise linear function, however, has given a general consideration for piecewise linear function description. In this sense, the result given by Lin et al. [22] is exceedingly noteworthy. In the rest of this section, we explain an overview of generalization given by Lin et al. [22].

Definition 2.8. [22] A linear function $f : \mathbb{R}^n \rightarrow \mathbb{R}^m$ is called *0th-level canonical*. For a positive integer K , a piecewise linear function $f : \mathbb{R}^n \rightarrow \mathbb{R}^m$ is called a *K th-level canonical*

if there exist a nonnegative integer l , a matrix $C \in \mathbb{R}^{m \times l}$, and $(K - 1)$ th-level canonical piecewise linear functions $g : \mathbb{R}^n \rightarrow \mathbb{R}^m$ and $h : \mathbb{R}^n \rightarrow \mathbb{R}^l$ such that

$$f(\mathbf{x}) = g(\mathbf{x}) + C|h(\mathbf{x})| \quad \forall \mathbf{x} \in \mathbb{R}^n, \quad (2.2)$$

where $|h| = (|h_1|, |h_2|, \dots, |h_l|)^T$ for $h = (h_1, h_2, \dots, h_l)^T$.

Remark 2.5. By definition, a piecewise linear function $f : \mathbb{R}^n \rightarrow \mathbb{R}^m$ possesses Chua canonical form if and only if f is first-level canonical. Moreover, every K th-level canonical piecewise linear function is $(K + 1)$ th-level canonical. The following proposition shows that every piecewise linear function can be expressed as (2.2).

Proposition 2.2. [22] *For every piecewise linear function f there exists a nonnegative integer K such that f is K th-level canonical.*

2.3 Linear complementarity representation

Definition 2.9. (cf. [10, 21]) A correspondence f from $\mathbf{x} \in \mathbb{R}^n$ to $\mathbf{y} \in \mathbb{R}^m$ is called a *linear complementarity correspondence*, an LCC for short, if there exist a nonnegative integer k , matrices $A \in \mathbb{R}^{m \times n}$, $B \in \mathbb{R}^{m \times k}$, $C \in \mathbb{R}^{k \times n}$, and $D \in \mathbb{R}^{k \times k}$, and vectors $\mathbf{g} \in \mathbb{R}^m$ and $\mathbf{h} \in \mathbb{R}^k$ such that

$$\mathbf{y} = A\mathbf{x} + B\mathbf{u} + \mathbf{g}, \quad (2.3)$$

$$\mathbf{j} = C\mathbf{x} + D\mathbf{u} + \mathbf{h}, \quad (2.4)$$

$$\mathbf{u}, \mathbf{j} \geq \mathbf{0}, \quad \langle \mathbf{u}, \mathbf{j} \rangle = 0. \quad (2.5)$$

The vectors \mathbf{u} and \mathbf{j} satisfying the equation (2.5) are called *complementarity vectors*, and the equations (2.3)–(2.5) are collectively called a *linear complementarity representation*. For the sake of simplicity, throughout this thesis, we will often use the notation $(A, B, \mathbf{g}; C, D, \mathbf{h})$ for a given representation.

Remark 2.6. Every linear function $A\mathbf{x} + \mathbf{g}$ has a representation $(A, O, \mathbf{g}; \mathbf{0}, 1, 0)$, where $A \in \mathbb{R}^{m \times n}$ and $\mathbf{g} \in \mathbb{R}^m$. This means that every linear function is an LCC. For convention of the arguments in Chapter 5, we will adopt the expression $(A; \mathbf{g})$ with zero-dimensional complementarity vectors, instead of the above one-dimensional representation.

In the linear complementarity representation, the problem of finding \mathbf{y} for each \mathbf{x} is reduced to a linear complementarity problem (an LCP for short) by substituting $\mathbf{q}(\mathbf{x}) =$

$C\mathbf{x} + \mathbf{h}$; that is, in order to calculate a function value, we must solve the LCP $(D, \mathbf{q}(\mathbf{x}))$ for each \mathbf{x} . Thus, in general, an LCC is a multi-valued function (the correspondence value might not exist). See Appendix A.2 for the definition of the LCP.

Remark 2.7. Since the linear complementarity vectors in this model are often called the state-variables, the model has often referred as state-variable representation. The calling “linear complementarity representation” is quoted from the calling “linear complementarity system” in hybrid system theory (see e.g., [14, 33, 34]).

As pointed out in [21], this model has such a considerable advantage that it can be regarded as a linear function by ignoring a complementarity condition. In addition, Heemels et al. [13] showed, in the investigation of mutual transformation among some hybrid dynamical models, that

Theorem 2.2. *Every piecewise linear function can be written as linear complementarity representation.*

Before now, a construction method of a linear complementarity representation for a given mapping has been developed [10] (see also [5, 21] for the method). However, this method is somewhat complicated. On the other hand, our construction method of a ULT-representation is exceedingly simple in mathematical and methodological points of view. Our method will be explained in Section 4.4.

2.4 Max-min polynomial

The next theorem indicates that the max-min polynomial is a characterization of scalar-valued piecewise linear functions.

Theorem 2.3. [28] *Let $f : \mathbb{R}^n \rightarrow \mathbb{R}$ be a piecewise linear function, and let $\{g^{(1)}, g^{(2)}, \dots, g^{(l)}\}$ be the set of its distinct segments. Then there exists a family $\{S_j\}_{j \in J}$ of incomparable (with respect to \subset) subsets of $[l]$ such that*

$$f(\mathbf{x}) = \bigvee_{j \in J} \bigwedge_{i \in S_j} g^{(i)}(\mathbf{x}) \quad (\text{for any } \mathbf{x} \in \mathbb{R}^n).$$

The expression on the right-hand side of the above formula is the disjunctive normal form of a max-min polynomial in the variables $g^{(i)}$. Conversely, every function having the above expression is a piecewise linear function.

This fact suggests the existence of a lattice structure on the family of all piecewise linear functions endowed with max and min operators. Indeed, the following holds.

Theorem 2.4. [1] *The family of all piecewise linear functions endowed with max and min operators is a Riesz subspace of the Riesz space consisting of all continuous functions.*

In order to illustrate Theorem 2.3, let us consider a piecewise linear function f as in Figure 2.1. In this case, the segments of f are $g^{(1)}, g^{(2)}, g^{(3)}$, and $g^{(4)}$. Then, we can choose the family of index sets as $S_1 = \{1, 2\}$ and $S_2 = \{3, 4\}$. Thus f has the representation $f = (g^{(1)} \wedge g^{(2)}) \vee (g^{(3)} \wedge g^{(4)})$.

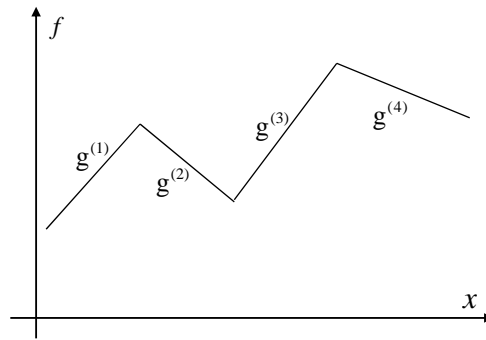

Figure 2.1: piecewise linear function with four segments

The next theorem is an extension of Theorem 2.3 to the vector-valued case.

Theorem 2.5. [28] *Let $f : \mathbb{R}^n \rightarrow \mathbb{R}^m$ be a piecewise linear function, and let $\{g^{(1)}, g^{(2)}, \dots, g^{(l)}\}$ be the set of its distinct segments. Then there exists a family $\{S_j^k\}_{j \in J, k \in [m]}$ of subsets of $[l]$ such that*

$$f_k(\mathbf{x}) = \bigvee_{j \in J} \bigwedge_{i \in S_j^k} g_k^{(i)}(\mathbf{x}) \quad (\text{for any } \mathbf{x} \in \mathbb{R}^n, 1 \leq k \leq m).$$

Converse is also true.

Remark 2.8. If we obtain a max-min polynomial for a given piecewise linear function, we can calculate function value for each \mathbf{x} through finite operations of max and min. This also implies that every calculation result does not contain any computational errors. On the other hand, the calculation through the representation based on the definition of piecewise linear function requires the determination of the polyhedron containing \mathbf{x} , this is a linear programming. Although we should take somewhat complicated procedure to

obtain a max-min polynomial for a given piecewise linear function, the former procedure is exceedingly easy to calculate function values in comparison with the later procedure. The procedure of constructing a max-min polynomial for each piecewise linear function has been provided by Ovchinnikov [28] and Tarela et al. [39] through a similar ideas, independently from each other: The construction method, as well as some examples, will be explained in Appendix D. See also Chapter 7 in [1] for the method.

Chapter 3

The Choquet integral as a piecewise linear function

As mentioned in Section 1.1, the multi-step Choquet integral is defined recursively from the Choquet integral, and thus, has a hierarchical structure (see Figure 3.1). This fact

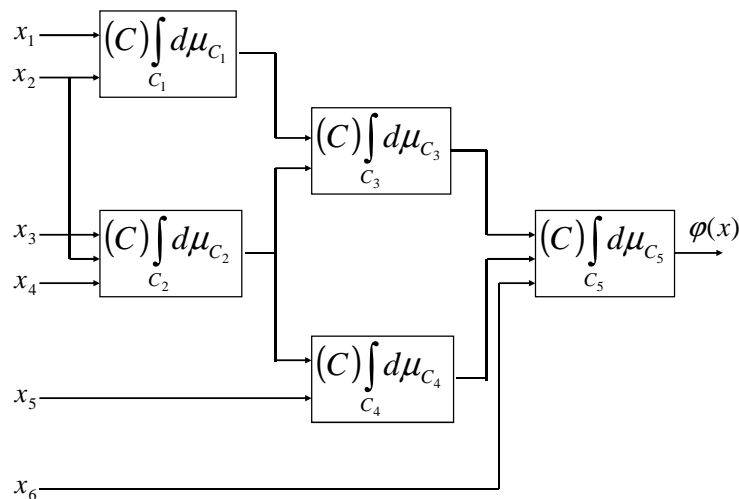

Figure 3.1: Example of multi-step Choquet integral

suggests that the multi-step Choquet integral would help us to understand each piecewise linear function in hierarchical manner. However, general consideration on multi-step Choquet integral would involve numerous difficulties. Therefore, at the first step toward the general consideration, we have investigated the one-step Choquet integral. The investigation discussed in this thesis is one of the experimental and preliminary study for our ultimate objective. In this chapter, we present our investigation of one-step Choquet integral as a piecewise linear function.

3.1 Definition and fundamental properties

Definition 3.1. [12, 23] A set function $\mu : 2^X \rightarrow \mathbb{R}$ is called a *fuzzy measure* (or *non-additive measure*) if

(i) $\mu(\emptyset) = 0$.

μ is called a *monotone* fuzzy measure if it satisfies (i) and the following:

(ii) $\mu(A) \leq \mu(B)$ whenever $A \subset B$.

Remark 3.1. Usually, a set function satisfying (i) is called a *non-monotonic* fuzzy measure, whereas a set function satisfying (i) and (ii) is called a *fuzzy measure* [12, 23]. We, however, adopt the above nonstandard terminology so that we deal mainly with set functions satisfying (i) in this thesis.

Definition 3.2. [12] The *Choquet integral* of a function $f : X \rightarrow \mathbb{R}$ with respect to a fuzzy measure μ is defined by

$$(C) \int_X f(j) d\mu(j) = \sum_{k=1}^n f(j_k) [\mu(A_k) - \mu(A_{k+1})], \quad (3.1)$$

where $k \mapsto j_k$ is a permutation on X such that $f(j_1) \leq f(j_2) \leq \dots \leq f(j_n)$. For $k = 1, 2, \dots, n$, we write $A_k = \{j_k, j_{k+1}, \dots, j_n\}$ and $A_{n+1} = \emptyset$.

The next proposition provides a feature of one-step Choquet integral as a piecewise linear function.

Proposition 3.1. [24, 27] Let μ be a fuzzy measure on X , then the following function $\varphi_\mu : \mathbb{R}^n \rightarrow \mathbb{R}$ is a piecewise linear function

$$\varphi_\mu(x_1, x_2, \dots, x_n) = (C) \int_X x_j d\mu(j), \quad (3.2)$$

where the integrand in the right hand side is $j \mapsto x_j$. Moreover, the piecewise linear function φ_μ has a linear partition $\{(\mathbf{e}_{ij}, 0)\}_{1 \leq i < j \leq n}$ of \mathbb{R}^n , where $\mathbf{e}_{ij} = (e_{ij1}, e_{ij2}, \dots, e_{ijn})$ is defined as

$$e_{ijk} = \begin{cases} 1 & \text{if } k = i, \\ -1 & \text{if } k = j, \\ 0 & \text{otherwise.} \end{cases}$$

The family of regions generated by $\{(\mathbf{e}_{ij}, 0)\}_{1 \leq i < j \leq n}$ is $\mathcal{R} = \{R_\sigma\}_{\sigma \in S}$, where S is the set of permutations on X and for $\sigma \in S$

$$R_\sigma = \{\mathbf{x} \in \mathbb{R}^n \mid x_{\sigma(1)} \leq \dots \leq x_{\sigma(n)}\}.$$

Furthermore, the linear component of φ_μ on R_σ is given by the right-hand side of (3.1) with the substitution of $f(j_k) = x_{\sigma(k)}$ and $j_k = \sigma(k)$, ($k = 1, 2, \dots, n$).

Finally, another expression of the Choquet integral is given. The expression is used in the discussion of Sections 3.2 and 3.3.

Definition 3.3. [12] Let μ be a fuzzy measure. The *Möbius inverse* of μ is the set function $\mu^m : 2^X \rightarrow \mathbb{R}$ defined by the following:

$$\mu^m(A) = \sum_{B \subset A} (-1)^{|A \setminus B|} \mu(B), \quad \forall A \subset X.$$

Definition 3.4. [12] For a positive integer k , a fuzzy measure μ is called *k-additive* if $\mu^m(A) = 0$ whenever $|A| > k$, and there exists at least one subset $A \subset X$ such that $|A| = k$ and $\mu^m(A) \neq 0$. In this case, we say that the *order of additivity* of μ is k .

Proposition 3.2. [12] Let μ be a fuzzy measure on X , then the following holds.

$$\mu(A) = \sum_{B \subset A} \mu^m(B), \quad \forall A \subset X.$$

Proposition 3.3. [12] The Choquet integral of a function $f : X \rightarrow \mathbb{R}$ with respect to a fuzzy measure μ is given by

$$(C) \int_X f(j) d\mu(j) = \sum_{\substack{A \subset X \\ A \neq \emptyset}} \bigwedge_{j \in A} f(j) \mu^m(A). \quad (3.3)$$

3.2 Chua canonical form of Choquet integral

In this section, we will attempt to express each Choquet integral as Chua canonical form. The key is how the condition (cv) will be expressed by means of fuzzy measure. The next lemma gives necessary and sufficient conditions for a given Choquet integral to have Chua canonical form.

Lemma 3.1. [31] Let μ be a fuzzy measure. Then the following three conditions are equivalent to one another.

- (i) The Choquet integral $\varphi_\mu(\mathbf{x})$ possesses the consistent variation property.
- (ii) For every pair $i, j \in X$ with $i < j$, there exists $c_{ij} \in \mathbb{R}$ such that for all $A \subset X \setminus \{i, j\}$

$$\mu(\{i, j\} \cup A) - \mu(\{j\} \cup A) - \mu(\{i\} \cup A) + \mu(A) = c_{ij}.$$

(iii) $\mu^m(A) = 0$ for all $A \subset X$ with $|A| > 2$.

The next theorem follows from Definition 3.4, Proposition 2.1, and Lemma 3.1.

Theorem 3.1. [31] *Let μ be a fuzzy measure. Then the Choquet integral $\varphi_\mu(\mathbf{x})$ possesses Chua canonical form if and only if μ is at most 2-additive. Moreover, Chua canonical form of the Choquet integral is given by*

$$\varphi_\mu(\mathbf{x}) = \sum_{i \in X} \left(\mu^m(\{i\}) + \frac{1}{2} \sum_{i \neq j} \mu^m(\{i, j\}) \right) x_i - \frac{1}{2} \sum_{i < j} \mu^m(\{i, j\}) \cdot |\langle \mathbf{e}_{ij}, \mathbf{x} \rangle|. \quad (3.4)$$

Example 3.1. Let $X = \{1, 2, 3, 4\}$, and consider the following fuzzy measure:

$$\begin{aligned} \mu(\{1\}) &= \mu(\{2\}) = \mu(\{3\}) = 1, \quad \mu(\{4\}) = 3, \\ \mu(\{1, 2\}) &= \mu(\{2, 3\}) = 2, \quad \mu(\{1, 4\}) = 4, \\ \mu(\{1, 3\}) &= \mu(\{2, 4\}) = \mu(\{3, 4\}) = 3, \\ \mu(\{1, 2, 3\}) &= 4, \quad \mu(\{2, 3, 4\}) = 3, \\ \mu(\{1, 2, 4\}) &= 4, \quad \mu(\{1, 3, 4\}) = 5, \quad \mu(X) = 5. \end{aligned}$$

Obviously, μ is 2-additive, and thus Chua canonical form of $\varphi_\mu(\mathbf{x})$ is obtained as follows:

$$\varphi_\mu(\mathbf{x}) = 1.5x_1 + 0.5x_2 + x_3 + 2x_4 - 0.5|x_1 - x_3| + 0.5|x_2 - x_4| + 0.5|x_3 - x_4|.$$

Remark 3.2. The two additivity of fuzzy measure is extremely restricted. Since the order of additivity is possible up to the number of elements, namely n , we need an appropriate generalization of Chua canonical form in order to express all Choquet integral with respect to higher order additive fuzzy measure. So far, we have investigated the relation between the generalization given by Lin et al. [22] and the Choquet integral, and provided a method of generating a canonical form of each Choquet integral [31]. The result also, unfortunately, found that the order of additivity of fuzzy measure and the nesting level of absolute-value sign are not a one-to-one correspondence. See Appendix C for details.

3.3 Linear complementarity representation of Choquet integral

In this section, we derive a linear complementarity representation of the Choquet integral. We begin with some notations.

For $E, F \subset X$, we defines the binominal relation \preceq as follows:

- $E \preceq F \stackrel{\text{def}}{\iff} E \subset F, E < F \setminus E,$

where for $G, H \subset X$ the relatin $<$ is defined by

- $G < H \stackrel{\text{def}}{\iff} \forall g \in G, \forall h \in H, g < h.$

The symbol $<$ of the right-hand side in the above is the usual one.

Remark 3.3. Relation $E \preceq F$ expresses “ E is a subset which has chosen the element of F from the smaller one.” Relation \preceq is an order relation on 2^X .

Example 3.2. Let $X = \{1, 2, 3, 4\}$. If $E_1 = \{1, 3\}$, $E_2 = \{1, 2\}$, $E_3 = \{1, 2, 3\}$, $E_4 = \{1, 4\}$ and $F = \{1, 2, 3\}$, then $E_2 \preceq F$ and $E_3 \preceq F$ are hold, but $E_1 \preceq F$ and $E_4 \preceq F$ are not hold.

The next theorem gives one of linear complementarity representation of Choquet integral.

Theorem 3.2. [32] *Every Choquet integral $\varphi_\mu(\mathbf{x})$ possesses the linear complementarity representation $(A, B, \mathbf{0}; C, D, 0)$, where when it sets with $\mathfrak{X} \triangleq \{E \subset X \mid |E| \geq 2\}$,*

- $\mathbf{j} = (j_E)_{E \in \mathfrak{X}}, \mathbf{u} = (u_E)_{E \in \mathfrak{X}} \in \mathbb{R}^{|\mathfrak{X}|},$
- $A = (a_i)_{i \in X} \in \mathbb{R}^{1 \times n}: a_i = \sum_{F \succeq \{i\}} \mu^m(F),$
- $B = (b_E)_{E \in \mathfrak{X}} \in \mathbb{R}^{1 \times |\mathfrak{X}|}: b_E = - \sum_{F \succeq E} \mu^m(F),$
- $C = (c_{E,j})_{E \in \mathfrak{X}, j \in X} \in \mathbb{R}^{|\mathfrak{X}| \times n}$

$$c_{E,j} = \begin{cases} 1 & j = \max E, \\ -1 & j = \min E, \\ 0 & \text{otherwise,} \end{cases}$$

- $D = (d_{E,F})_{E,F \in \mathfrak{X}} \in \mathbb{R}^{|\mathfrak{X}| \times |\mathfrak{X}|}$

$$d_{E,F} = \begin{cases} 1 & F \preceq E, \\ 0 & \text{otherwise.} \end{cases}$$

Proof. See Appendix B.2. □

Example 3.3. Let $X = \{1, 2, 3\}$, and consider the fuzzy measure given by the following:

$$\mu(\{1\}) = \mu(\{2\}) = 1, \mu(\{3\}) = 2, \mu(\{1, 2\}) = \mu(\{2, 3\}) = 2, \mu(\{1, 3\}) = 3, \mu(X) = 4.$$

Moreover, we let $E_1 = \{1, 2\}$, $E_2 = \{2, 3\}$, $E_3 = \{1, 3\}$ and $E_4 = X$, then the linear complementarity representation of Choquet integral with respect to μ is obtained as follows:

$$A = \begin{pmatrix} 1 & -1 & 0 \end{pmatrix}, B = \begin{pmatrix} -1 & 0 & 0 & -1 \end{pmatrix}, C = \begin{pmatrix} -1 & 1 & 0 \\ 0 & -1 & 1 \\ -1 & 0 & 1 \\ -1 & 0 & 1 \end{pmatrix}, D = \begin{pmatrix} 1 & 0 & 0 & 0 \\ 0 & 1 & 0 & 0 \\ 0 & 0 & 1 & 0 \\ 1 & 0 & 0 & 1 \end{pmatrix}.$$

3.4 Max-min polynomial of Choquet integral

In this section, we consider the max-min polynomial of Choquet integral. We begin with the following two examples.

Example 3.4. Consider the fuzzy measure μ on $X = \{1, 2\}$ defined as $\mu(\{1\}) = \mu(\{2\}) = 1$, $\mu(X) = 3$. Then the Choquet integral φ_μ with respect to μ is obtained as follows:

$$\varphi(x_1, x_2) = \begin{cases} 2x_1 + x_2 & P_1 = \{(x_1, x_2) \in \mathbb{R}^2 \mid x_1 \leq x_2\}, \\ 2x_2 + x_1 & P_2 = \{(x_1, x_2) \in \mathbb{R}^2 \mid x_2 \leq x_1\}. \end{cases}$$

The linear components in this case are $g_1(x_1, x_2) = 2x_1 + x_2$ and $g_2(x_1, x_2) = 2x_2 + x_1$. Since $g_1 \leq g_2$ on P_1 and $g_2 \leq g_1$ on P_2 hold, the max-min polynomial of φ_μ is of the form $\varphi_\mu = g_1 \wedge g_2$.

Example 3.5. Consider the fuzzy measure μ on $X = \{1, 2\}$ defined as $\mu(\{1\}) = \mu(\{2\}) = 1$, $\mu(X) = -3$; in this case, μ is non-monotonic. Then the Choquet integral φ_μ with respect to μ is obtained as follows:

$$\varphi(x_1, x_2) = \begin{cases} -4x_1 + x_2 & P_1 = \{(x_1, x_2) \in \mathbb{R}^2 \mid x_1 \leq x_2\}, \\ -4x_2 + x_1 & P_2 = \{(x_1, x_2) \in \mathbb{R}^2 \mid x_2 \leq x_1\}. \end{cases}$$

The linear components in this case are $g_1(x_1, x_2) = -4x_1 + x_2$ and $g_2(x_1, x_2) = -4x_2 + x_1$. Since $g_2 \leq g_1$ on P_1 and $g_1 \leq g_2$ on P_2 hold, the max-min polynomial of φ_μ is of the form $\varphi_\mu = g_1 \vee g_2$.

The above examples may unfortunately indicate that we could not obtain the general formula of the Choquet integral: The formula would be extremely complicated, if we could find. Therefore, finding a max-min polynomial of the Choquet integral would need to proceed a construction method given by Ovchinnikov [28] or Tarela et al. [39].

3.5 Summary

In this chapter, we described our research findings on the relationships among the Choquet integral and the representations explained in Chapter 2. Figure 3.2 summarizes the

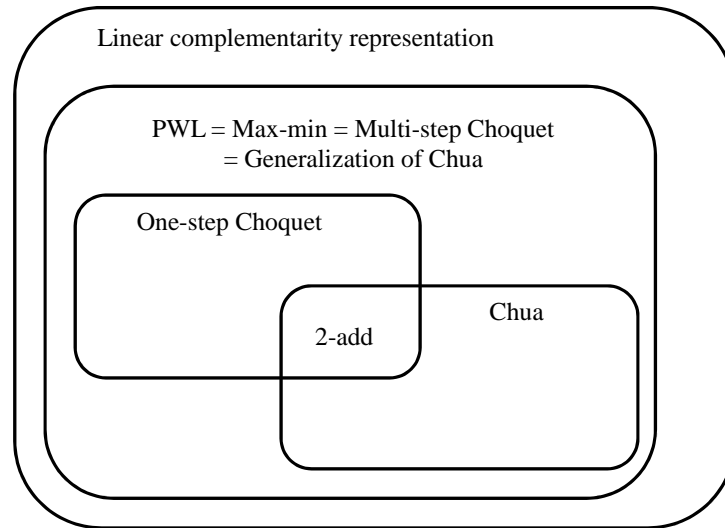

Figure 3.2: Relationships among representations of piecewise linear functions

relationships among them. As explained at the beginning of this chapter, the results obtained in this chapter is an experimental and preliminary study. Based on the result of this chapter, we will survey the multi-step Choquet integral as a piecewise linear function. As future works, we will pose the following viewpoints:

- (i) We will study which model is most appropriate for analyzing specific issues through case study.
- (ii) We will study the hierarchical structure of multi-step Choquet integral brings what advantages to the analysis of piecewise linear models: It is well known that the hierarchical structure is extremely advantageous for the analysis of decision-making processes (see e.g., [12]).

Chapter 4

The linear complementarity representation

In this chapter, we discuss about the P-representation and the ULT-representation. Section 4.1 introduces the P-representation and the ULT-representation. Section 4.2 provides a fundamental property of the ULT-representation, which states that the class of all correspondences having this representation (called Class ULT) is closed under the operations of max and min composition, direct sum, composition, and linear combination. Section 4.3 proves the coincidences of Class P (the class of all correspondences having a P-representation), Class ULT, and the class of all piecewise linear functions. Section 4.4 demonstrates the construction of a ULT-representation for a given piecewise linear function through a simple example. Section 4.5 explains the transformation from a P-representation to a ULT-representation. Section 4.6 is devoted to the summary of Chapter 4, and further problem institution of the linear complementarity representation discussed in Chapter 5.

4.1 P-representation and ULT-representation

P-representation and ULT-representation are defined as follows.

Definition 4.1. (cf. [3, 19]) (a) *P-representation* is a linear complementarity representation whose coefficient D in (2.4) is a P-matrix. The family of LCCs having a P-representation is called *Class P*, and denoted by \mathbf{P} .

(b) *ULT-representation* is a linear complementarity representation whose coefficient D in (2.4) is a ULT-matrix. The family of LCCs having a ULT-representation is called *Class ULT*, and denoted by \mathbf{ULT} . See Definition A.7 in Appendix A.2 for the definition of

P-matrix and ULT-matrix.

Since \mathbf{P} and \mathbf{ULT} are both the classes of single-valued functions as mentioned in Remark 4.1, it is important to clarify the relation among \mathbf{P} , \mathbf{ULT} , and \mathbf{PWL} . Moreover, since P-representation and ULT-representation have useful advantages as mentioned later, it is also important to clarify basic properties about them.

Remark 4.1. It is clear by the definitions of P-matrix and ULT-matrix that $\mathbf{P} \supset \mathbf{ULT}$. As mentioned in Remark 2.6 that every linear function has a representation $(A, O, \mathbf{g}; \mathbf{0}, 1, 0)$. This is a ULT-representation. Thus, every linear function belongs to both \mathbf{P} and \mathbf{ULT} . Though an LCC is, in general, a multi-valued function, Proposition A.1 in Appendix A.2 guarantees that every LCC in \mathbf{P} becomes a single-valued function. The next theorem states that every LCC in \mathbf{P} is, in fact, piecewise linear function.

Theorem 4.1. (See [3, 19]) *Classes \mathbf{P} and \mathbf{ULT} are both contained in the family of all piecewise linear functions, that is, $\mathbf{ULT} \subset \mathbf{P} \subset \mathbf{PWL}$.*

Lastly, we summarize the advantages of P-representation and ULT-representation.

The advantages of P-representation

- (i) It is a single-valued function. Thus theoretical treatment is simple.
- (ii) There are many research findings of P-matrices (See e.g., [9, 25]). Thus we expect that the results of P-matrices can bring many advantages to the research field of piecewise linear functions through the LCC.

The advantages of ULT-representation

- (i) It is a special type of P-representation. Therefore, it has all the advantages of P-representation.
- (ii) The structure of representation is very simple. Especially, by using the back substitution method, which is one of the solution method of the LCP, complementarity vector can be deleted from the representation at a polynomial step. In other words, we can easily transform every ULT-representation to an explicit representation. See [25] for the back substitution method.

4.2 Operations on ULT

In this section, we provide important tools used in the rest of this thesis. The following theorem shows that \mathbf{ULT} is closed under the operations of max and min compositions,

direct sum, composition, and linear combination.

Lemma 4.1. *Let $D \in \mathbb{R}^{k \times k}$ and $D' \in \mathbb{R}^{k' \times k'}$ be ULT-matrices. Then so is the matrix of the form:*

$$\begin{pmatrix} D & O \\ * & D' \end{pmatrix}.$$

Proof. It is clear by the definition of ULT-matrix. \square

Theorem 4.2. [32] *The following four statements are true.*

(i) *If a function $f : \mathbb{R}^n \rightarrow \mathbb{R}$ has a ULT-representation, say $(A, B, \mathbf{g}; C, D, \mathbf{h})$, and a function $f' : \mathbb{R}^n \rightarrow \mathbb{R}$ has a ULT-representation, say $(A', B', \mathbf{g}'; C', D', \mathbf{h}')$, then their max $f \vee f'$ and min $f \wedge f'$ have the ULT-representations:*

$$f \vee f' : \left(A', (O \ B' \ 1), \mathbf{g}'; \begin{pmatrix} C \\ C' \\ A' - A \end{pmatrix}, \begin{pmatrix} D & O & \mathbf{0} \\ O & D' & \mathbf{0} \\ -B & B' & 1 \end{pmatrix}, \begin{pmatrix} \mathbf{h} \\ \mathbf{h}' \\ \mathbf{g}' - \mathbf{g} \end{pmatrix} \right),$$

$$f \wedge f' : \left(A, (B \ O \ -1), \mathbf{g}; \begin{pmatrix} C \\ C' \\ A' - A \end{pmatrix}, \begin{pmatrix} D & O & \mathbf{0} \\ O & D' & \mathbf{0} \\ -B & B' & 1 \end{pmatrix}, \begin{pmatrix} \mathbf{h} \\ \mathbf{h}' \\ \mathbf{g}' - \mathbf{g} \end{pmatrix} \right).$$

(ii) *If a function $f : \mathbb{R}^n \rightarrow \mathbb{R}^m$ has a ULT-representation, say $(A, B, \mathbf{g}; C, D, \mathbf{h})$, and a function $f' : \mathbb{R}^n \rightarrow \mathbb{R}^{m'}$ has a ULT-representation, say $(A', B', \mathbf{g}'; C', D', \mathbf{h}')$, then their direct sum $f'' = f \oplus f' : \mathbb{R}^n \rightarrow \mathbb{R}^{m+m'}$ has the ULT-representation:*

$$\left(\begin{pmatrix} A \\ A' \end{pmatrix}, \begin{pmatrix} B & O \\ O & B' \end{pmatrix}, \begin{pmatrix} \mathbf{g} \\ \mathbf{g}' \end{pmatrix}; \begin{pmatrix} C \\ C' \end{pmatrix}, \begin{pmatrix} D & O \\ O & D' \end{pmatrix}, \begin{pmatrix} \mathbf{h} \\ \mathbf{h}' \end{pmatrix} \right).$$

(iii) *If a function $f : \mathbb{R}^n \rightarrow \mathbb{R}^m$ has a ULT-representation, say $(A, B, \mathbf{g}; C, D, \mathbf{h})$, and a function $f' : \mathbb{R}^m \rightarrow \mathbb{R}^{m'}$ has a ULT-representation, say $(A', B', \mathbf{g}'; C', D', \mathbf{h}')$, then their composition $f'' = f' \circ f : \mathbb{R}^n \rightarrow \mathbb{R}^{m'}$ has the ULT-representation:*

$$\left(A'A, (A'B \ B'), A'\mathbf{g} + \mathbf{g}'; \begin{pmatrix} C \\ C'A \end{pmatrix}, \begin{pmatrix} D & O \\ C'B & D' \end{pmatrix}, \begin{pmatrix} \mathbf{h} \\ C'\mathbf{g} + \mathbf{h}' \end{pmatrix} \right).$$

(iv) *If a function $f : \mathbb{R}^n \rightarrow \mathbb{R}^m$ has a ULT-representation, say $(A, B, \mathbf{g}; C, D, \mathbf{h})$, and a function $f' : \mathbb{R}^n \rightarrow \mathbb{R}^m$ has a ULT-representation, say $(A', B', \mathbf{g}'; C', D', \mathbf{h}')$, then their linear combination $\lambda f + \nu f' : \mathbb{R}^n \rightarrow \mathbb{R}^m$, where $\lambda, \nu \in \mathbb{R}$, has the ULT-representation:*

$$\left(\lambda A + \nu A', (\lambda B \ \nu B'), \lambda \mathbf{g} + \nu \mathbf{g}'; \begin{pmatrix} C \\ C' \end{pmatrix}, \begin{pmatrix} D & O \\ O & D' \end{pmatrix}, \begin{pmatrix} \mathbf{h} \\ \mathbf{h}' \end{pmatrix} \right).$$

Proof. See Appendix B.3. \square

Remark 4.2. In the proof of the relation $\mathbf{PWL} \subset \mathbf{ULT}$, we take advantage of these closedness. Moreover, in Theorem 4.2 and its proofs, the term ‘‘ULT’’ can be replaced by ‘‘P’’. Thus it turns out that these operations and the closedness are valid for Class P.

The following corollary is easily shown by induction on the number of operators.

Corollary 4.1. *Let f_1, f_2, \dots, f_l be correspondences from \mathbb{R}^n to \mathbb{R} . If each of them has ULT-representation, then we obtain the following:*

(i) $f_1 \vee f_2 \vee \dots \vee f_l : \mathbb{R}^n \rightarrow \mathbb{R}$ has ULT-representation;

(ii) $f_1 \wedge f_2 \wedge \dots \wedge f_l : \mathbb{R}^n \rightarrow \mathbb{R}$ has ULT-representation.

If correspondence $f_k : \mathbb{R}^n \rightarrow \mathbb{R}^{m_k}$, for all $k \in [l]$, has ULT-representation. Then

(iii) $f_1 \oplus f_2 \oplus \dots \oplus f_l : \mathbb{R}^n \rightarrow \mathbb{R}^{m_1+m_2+\dots+m_l}$ has ULT-representation.

Moreover, if $m_1 = m_2 = \dots = m_l = m$, then the following is also true:

(iv) $\lambda_1 f_1 + \lambda_2 f_2 + \dots + \lambda_l f_l : \mathbb{R}^n \rightarrow \mathbb{R}^m$ has ULT-representation, where $\lambda_1, \lambda_2, \dots, \lambda_l \in \mathbb{R}$.

Let each of correspondences $f_1 : \mathbb{R}^n \rightarrow \mathbb{R}^{m_1}, \dots, f_l : \mathbb{R}^{m_{l-1}} \rightarrow \mathbb{R}^{m_l}$ have ULT-representation. Then

(v) $f_l \circ \dots \circ f_2 \circ f_1 : \mathbb{R}^n \rightarrow \mathbb{R}^{m_l}$ has ULT-representation.

4.3 Coincidence of P, ULT, and PWL

Theorem 4.3. [32] *Every piecewise linear function belongs to Class ULT, that is, $\mathbf{PWL} \subset \mathbf{ULT}$.*

Proof. Let $\mathbf{f} = (f_1, f_2, \dots, f_m) : \mathbb{R}^n \rightarrow \mathbb{R}^m \in \mathbf{PWL}$. By Theorem 2.5, it can be expressed as

$$f_k(\mathbf{x}) = \bigvee_{j \in J} \bigwedge_{i \in S_j^k} g_k^{(i)}(\mathbf{x}) \quad (\text{for any } \mathbf{x} \in \mathbb{R}^n, 1 \leq k \leq m),$$

where $\{g_k^{(i)}\}_{i \in [l]}$ is the set of distinct segments of f_k and $\{S_j^k\}_{j \in J, k \in [l]}$ is a family of subsets of $[l]$. Now $g_k^{(i)}$ is a linear function for any i . Therefore $\bigwedge_{i \in S_j^k} g_k^{(i)}$ has ULT-representation by Corollary 4.1(ii); furthermore, so does $\bigvee_{j \in J} \bigwedge_{i \in S_j^k} g_k^{(i)}$ by Corollary 4.1(i). That is, f_k has ULT-representation. The assertion is valid for all k . Thus Corollary 4.1(iii) implies that $\mathbf{f} = (f_1, f_2, \dots, f_m)$ has ULT-representation. \square

By Theorem 4.1 and Theorem 4.3, we have the following.

Corollary 4.2. *The family of all piecewise linear functions coincides with Classes P and ULT, that is, $\mathbf{P} = \mathbf{ULT} = \mathbf{PWL}$.*

Remark 4.3. The proof for Theorem 4.3 gives the method of transforming a max-min polynomial to a ULT-representation. On the one hand, Ovchinnikov has given the method

of constructing a max-min polynomial of piecewise linear function represented in a listed expression (See [28]). Thus, we can transform every piecewise linear function represented in a listed expression to a ULT-representation.

4.4 Construction of ULT-representation

In this section, we demonstrate the method of constructing a ULT-representation for a given piecewise linear function. The procedure consists of the following two steps: The first step is the procedure of determining a max-min polynomial by means of Ovchinnikov's method as explained in Appendix D. The second step is the procedure of transforming a max-min polynomial into a ULT-representation. The second step is directly obtained from the procedure of the proof of Theorem 4.3.

Example 4.1. Consider the piecewise linear function $f : \mathbb{R}^2 \rightarrow \mathbb{R}$ defined as follows (see also Figure 4.1):

$$f(x, y) = \begin{cases} g_1(x, y) & x, y \geq 0 \\ g_2(x, y) & x \leq 0, 0 \leq y \\ g_3(x, y) & y \leq 0, 2x \leq y \\ g_4(x, y) & y \leq 0, y \leq 2x, \end{cases}$$

where $g_1(x, y) = x - y$, $g_2(x, y) = -x - y$, $g_3(x, y) = -x + y$, and $g_4(x, y) = x$. First of all, we determine the max-min polynomial of f . By the same procedure as in Example D.1 of Appendix D, a max-min polynomial of f is obtained as follows:

$$f = (g_1 \wedge g_4) \vee (g_2 \wedge g_3). \quad (4.1)$$

Secondary, we transform the right hand side of (4.1) to a ULT-representation. By Theorem 4.2.(ii), a ULT-representation of $g_1 \wedge g_4$ will be obtained as follows:

$$((1 \ -1), -1, 0; (0 \ 1), 1, 0).$$

Similarly, a ULT-representation of $g_2 \wedge g_3$ will be obtained as follows:

$$((-1 \ -1), -1, 0; (0 \ 2), 1, 0).$$

Thus, by Theorem 4.2.(i), we have a ULT-representation of the right hand side of (4.1) as follows:

$$\left((-1 \ -1), (0 \ -1 \ 1), 0; \begin{pmatrix} 0 & 1 \\ 0 & 2 \\ -2 & 0 \end{pmatrix}, \begin{pmatrix} 1 & 0 & 0 \\ 0 & 1 & 0 \\ 1 & -1 & 1 \end{pmatrix}, \begin{pmatrix} 0 \\ 0 \\ 0 \end{pmatrix} \right).$$

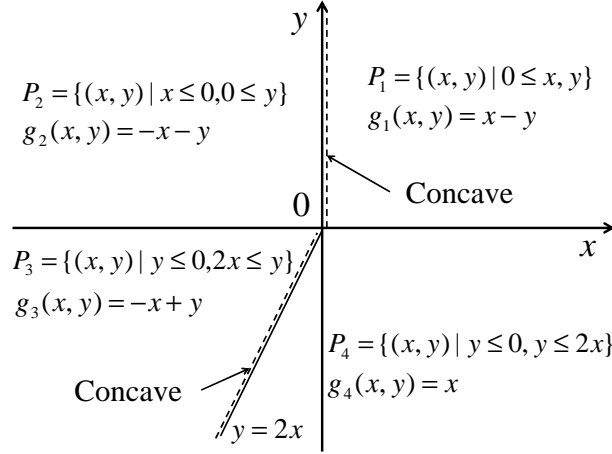

Figure 4.1: Two-variable piecewise linear function

Remark 4.4. Note, at Example 4.1, that, since $u_2(x, y) = 2u_1(x, y)$ holds for all $(x, y) \in \mathbb{R}^2$, we can omit the variable u_2 from the representation. Thus, in this case, the above ULT-representation is reduced to the following ULT-representation with lower dimensional complementarity vectors. This fact motivates us to consider the minimization problem of the linear complementarity representation. The problem will be discussed in the next chapter.

$$\left((-1 \ -1), (-2 \ 1), 0; \begin{pmatrix} 0 & 1 \\ -2 & 0 \end{pmatrix}, \begin{pmatrix} 1 & 0 \\ -1 & 1 \end{pmatrix}, \begin{pmatrix} 0 \\ 0 \end{pmatrix} \right).$$

4.5 Transforming a representation: from P to ULT

In this subsection, we show that every P-representation can be transformed to a ULT-representation, and explain the transformation method from P-representation to ULT-representation. The result of this section is an another application of the result of Section 4.2. Although this transformation gives a solution method of the LCP with P-matrix, it is not suitable as a solution method in view of efficiency. The significance of this method does not lie on giving a solution method of the LCP with P-matrix, but obtaining a method of transforming an implicit representation to an explicit representation in algorithmic way. We often need an explicit representation rather than an implicit representation, when we calculate a function value. Notice this transformability was mentioned in [20] without proof for a general case, and it was only demonstrated in a case of two-dimensional complementarity vectors. Unless otherwise noted, we assume that k is a positive integer

and $D \in \mathbb{R}^{k \times k}$ is a P-matrix. Firstly, we define the notion of “reduced” LCP.

Definition 4.2. For a given LCP (D, \mathbf{q}) , let us define the *reduced* LCP $(D_{-p}, \mathbf{q}_{-p})$ with respect to an index $p \in [k]$ as follows:

$$\mathbf{j}_{-p} = D_{-p} \mathbf{u}_{-p} + \mathbf{q}_{-p}, \quad (4.2)$$

$$\mathbf{u}_{-p}, \mathbf{j}_{-p} \geq \mathbf{0}, \quad \langle \mathbf{u}_{-p}, \mathbf{j}_{-p} \rangle = 0, \quad (4.3)$$

where $D_{-p} = (d_{ij})_{i,j \neq p} \in \mathbb{R}^{(k-1) \times (k-1)}$ for $D = (d_{ij})_{i,j \in [k]}$ and $\mathbf{v}_{-p} = (v_1, \dots, v_{p-1}, v_{p+1}, \dots, v_k) \in \mathbb{R}^{k-1}$ for $\mathbf{v} = (v_1, v_2, \dots, v_k)$. Clearly, D_{-p} is a P-matrix. Notice that this reduction can proceed until the dimension of the LCP is one.

The next lemma shows a relation between the solution to (D, \mathbf{q}) and the solution to $(D_{-p}, \mathbf{q}_{-p})$. According to Lemma 4.2, the solution to (D, \mathbf{q}) can be obtained from the solution to $(D_{-p}, \mathbf{q}_{-p})$ through the relation (4.6). On the basis of this relation, we can obtain a solution algorithm for the LCP with P-matrix.

Lemma 4.2. [3] *Let $\bar{\mathbf{j}} \in \mathbb{R}^k$ be the unique solution to (D, \mathbf{q}) and let $\hat{\mathbf{u}}_{-p} \in \mathbb{R}^{k-1}$ be the unique solution to $(D_{-p}, \mathbf{q}_{-p})$ with respect to an index p . Then the p -th component $\bar{j}_p \in \mathbb{R}$ of $\bar{\mathbf{j}}$ is the unique solution to the following LCP:*

$$j_p = d_{pp} u_p + q_p + \sum_{i \neq p} d_{pi} \hat{u}_i, \quad (4.4)$$

$$u_p, j_p \geq 0, \quad u_p \cdot j_p = 0. \quad (4.5)$$

Namely, the following relation holds:

$$\bar{j}_p = \left(q_p + \sum_{i \neq p} d_{pi} \hat{u}_i \right)^+. \quad (4.6)$$

Secondly, the notion of the “derived” LCP is introduced.

Definition 4.3. Let $C \in \mathbb{R}^{k \times n}$, $D \in \mathbb{R}^{k \times k}$, and $\mathbf{h} \in \mathbb{R}^k$. For each $\mathbf{x} \in \mathbb{R}^n$, we define the LCP $(D, \mathbf{q}(\mathbf{x}))$, where $\mathbf{q}(\mathbf{x}) = C\mathbf{x} + \mathbf{h}$. We call this the *derived* LCP from (C, D, \mathbf{h}) .

Since D is a P-matrix, the solution $(\mathbf{u}(\mathbf{x}), \mathbf{j}(\mathbf{x}))$ to $(D, \mathbf{q}(\mathbf{x}))$ is uniquely determined for each $\mathbf{x} \in \mathbb{R}^n$. In this case, the correspondences $\mathbf{x} \mapsto \mathbf{u}(\mathbf{x})$ and $\mathbf{x} \mapsto \mathbf{j}(\mathbf{x})$ are single-valued functions. The next lemma shows that $\mathbf{u}(\mathbf{x})$ and $\mathbf{j}(\mathbf{x})$ have ULT-representation and hence that they are in fact piecewise linear functions by Theorem 4.1.

Lemma 4.3. *Let $C \in \mathbb{R}^{k \times n}$, $\mathbf{h} \in \mathbb{R}^k$ and let $\mathbf{q}(\mathbf{x}) = C\mathbf{x} + \mathbf{h}$ ($\mathbf{x} \in \mathbb{R}^n$). Then the correspondences $\mathbf{x} \mapsto \mathbf{u}(\mathbf{x})$ and $\mathbf{x} \mapsto \mathbf{j}(\mathbf{x})$, where $(\mathbf{u}(\mathbf{x}), \mathbf{j}(\mathbf{x}))$ is the solution to $(D, \mathbf{q}(\mathbf{x}))$, have ULT-representation.*

Proof. By induction on the order k of D . By Theorem 4.2.(ii), it suffices to show that each component of $\mathbf{u}(\mathbf{x})$ and $\mathbf{j}(\mathbf{x})$ has a ULT-representation. For $k = 1$ (i.e., for some $\mathbf{c} \in \mathbb{R}^n$ and $h \in \mathbb{R}$, we have $\mathbf{q}(\mathbf{x}) = \mathbf{c}^T \mathbf{x} + h$, and D is a positive number d), by Remark A.4 of Appendix, we have the following:

$$u(\mathbf{x}) = \left(-\frac{q(\mathbf{x})}{d} \right)^+, \quad j(\mathbf{x}) = q(\mathbf{x})^+,$$

where $(u(\mathbf{x}), j(\mathbf{x}))$ is the solutions to the LCP $(d, q(\mathbf{x}))$. Since they are maximums of linear functions, they have ULT-representations by Theorem 4.2.(i) and Remark 4.1. Now suppose that for $k - 1$, the assertion holds. By Lemma 4.2, each $j_p(\mathbf{x})$ ($p \in [k]$) can be obtained from the solution $\hat{\mathbf{u}}_{-p}(\mathbf{x})$ to the reduced LCP $(D_{-p}, \mathbf{q}_{-p}(\mathbf{x}))$ as follows:

$$j_p(\mathbf{x}) = \left(q_p(\mathbf{x}) + \sum_{i \neq p} d_{pi} \hat{u}_i(\mathbf{x}) \right)^+.$$

By the induction assumption, each $\hat{u}_i(\mathbf{x})$ has a ULT-representation. Thus by Theorem 4.2 (i) and (iv), so does $j_p(\mathbf{x})$. The proof for $\mathbf{u}(\mathbf{x})$ can be obtained from the above argument applied to the LCP $(D^{-1}, -D^{-1}\mathbf{q}(\mathbf{x}))$ (see Remark A.3 of Appendix A.2). \square

By Lemma 4.3, we have the following.

Theorem 4.4. [32] *Every P-representation can be transformed to a ULT-representation.*

Proof. Let $(A, B, \mathbf{g}; C, D, \mathbf{h})$ be a P-representation. By Lemma 4.3, the complementarity vector in this representation has a ULT-representation, say $(A', B', \mathbf{g}'; C', D', \mathbf{h}')$. Then, we can easily show that the original LCC has the ULT-representation $(A+BA', BB', B\mathbf{g}' + \mathbf{g}; C', D', \mathbf{h}')$. \square

Finally, we describe a transformation method of finding a ULT-representation for a given P-representation (Remark 4.5), and demonstrate the transformation (Example 4.2).

Remark 4.5. To summarize the proofs of Lemma 4.3 and Theorem 4.4, we obtain a transformation method from P-representation to ULT-representation. We will explain only the process of finding a ULT-representation of the complementarity vector:

(a) In the case of $k = 1$. Since $u(\mathbf{x})$ can be obtained from the following form

$$u(\mathbf{x}) = 0 \vee \left(-\frac{1}{D}(C\mathbf{x} + h) \right).$$

Then $u(\mathbf{x})$ has a ULT-representation $(\mathbf{0}, \mathbf{1}, \mathbf{0}; C/D, 1, h/D)$.

(b) In the case of $k \geq 2$. Repeat the reduction process from D to $D-p$ until the dimension of the LCP $(D-p, \mathbf{q}_{-p}(\mathbf{x}))$ is one.

(c) Find ULT-representations of all the solutions to the one-dimensional reduced LCP by (a).

(d) Begin with the ULT-representations of one-dimensional LCP, find ULT-representations of all the solution to the reduced LCP in a recursive way. The procedure is as follows:

1. Let $(E, \mathbf{r}(\mathbf{x}))$ be an l -dimensional reduced LCP, and let $(\bar{\mathbf{u}}(\mathbf{x}), \bar{\mathbf{j}}(\mathbf{x}))$ be the solution to it. Moreover, for $p \in [l]$, let $\hat{\mathbf{u}}_{-p}(\mathbf{x})$ be the solution to the reduced LCP $(E_{-p}, \mathbf{r}_{-p}(\mathbf{x}))$. Suppose that $\hat{\mathbf{u}}_{-p}(\mathbf{x})$ is represented in a ULT-representation.
2. Calculate a ULT-representation of the formula $r_p(\mathbf{x}) + \sum_{i \neq p} e_{pi} \hat{u}_i(\mathbf{x})$ by Theorem 4.2 (iv).
3. Calculate a ULT-representation of $\bar{j}_p(\mathbf{x})$ by Theorem 4.2 (i) through (4.6).
4. Calculate a ULT-representation of $\bar{\mathbf{j}}(\mathbf{x})$ through the relation $\bar{\mathbf{j}}(\mathbf{x}) = (\bar{j}_1 \times \bar{j}_2 \times \cdots \times \bar{j}_l)(\mathbf{x})$.
5. Calculate a ULT-representation of $\bar{\mathbf{u}}(\mathbf{x})$ through the relation $\bar{\mathbf{u}}(\mathbf{x}) = E^{-1}(\bar{\mathbf{j}}(\mathbf{x}) - \mathbf{r}(\mathbf{x}))$.

Example 4.2. Consider the following derived LCP with a P-matrix:

$$\mathbf{j} = \begin{pmatrix} 3 & 6 & 3 \\ 4 & 2 & 2 \end{pmatrix} \mathbf{x} + \begin{pmatrix} 3 & 1 \\ 5 & 2 \end{pmatrix} \mathbf{u} + \begin{pmatrix} 3 \\ 0 \end{pmatrix}.$$

Firstly, we calculate ULT-representations of the solution to two reduced LCPs:

$$\begin{aligned} \hat{j}_1 &= (3 \ 6 \ 3) \mathbf{x} + 3\hat{u}_1 + 3, \\ \hat{j}_2 &= (4 \ 2 \ 2) \mathbf{x} + 2\hat{u}_2. \end{aligned}$$

By (a) of Remark 4, $\hat{u}_1(\mathbf{x})$ and $\hat{u}_2(\mathbf{x})$ have ULT-representations respectively:

$$(\mathbf{0}, 1, 0; (1 \ 2 \ 1), 1, 1) \quad \text{and} \quad (\mathbf{0}, 1, 0; (2 \ 1 \ 1), 1, 0).$$

Then, by Theorem 4.2 (iv), $(3 \ 6 \ 3) \mathbf{x} + \widehat{u}_2 + 3$ has the ULT-representation

$$((3 \ 6 \ 3), 1, 3; (2 \ 1 \ 1), 1, 0),$$

and $(4 \ 2 \ 2) \mathbf{x} + 5\widehat{u}_1$ has the ULT-representation

$$((4 \ 2 \ 2), 5, 0; (1 \ 2 \ 1), 1, 1).$$

Thus, ULT-representations of $j_1(\mathbf{x})$ and $j_2(\mathbf{x})$ are obtained by Theorem 4.2 (i) through (4.6) as follows:

$$\begin{aligned} & \left((0 \ 0 \ 0), (0 \ 1), 0; \begin{pmatrix} 2 & 1 & 1 \\ -3 & -6 & -3 \end{pmatrix}, \begin{pmatrix} 1 & 0 \\ -1 & 1 \end{pmatrix}, \begin{pmatrix} 0 \\ -3 \end{pmatrix} \right), \\ & \left((0 \ 0 \ 0), (0 \ 1), 0; \begin{pmatrix} 1 & 2 & 1 \\ -4 & -2 & -2 \end{pmatrix}, \begin{pmatrix} 1 & 0 \\ -5 & 1 \end{pmatrix}, \begin{pmatrix} 1 \\ 0 \end{pmatrix} \right). \end{aligned}$$

Finally, by Theorem 4.2 (ii), we obtain a ULT-representation of $\mathbf{j}(\mathbf{x})$ as

$$\left(\begin{pmatrix} 0 & 0 & 0 \\ 0 & 0 & 0 \end{pmatrix}, \begin{pmatrix} 0 & 1 & 0 & 0 \\ 0 & 0 & 0 & 1 \end{pmatrix}, \begin{pmatrix} 0 \\ 0 \end{pmatrix}; \begin{pmatrix} 2 & 1 & 1 \\ -3 & -6 & -3 \\ 1 & 2 & 1 \\ -4 & -2 & -2 \end{pmatrix}, \begin{pmatrix} 1 & 0 & 0 & 0 \\ -1 & 1 & 0 & 0 \\ 0 & 0 & 1 & 0 \\ 0 & 0 & -5 & 1 \end{pmatrix}, \begin{pmatrix} 0 \\ -3 \\ 1 \\ 0 \end{pmatrix} \right),$$

and hence the ULT-representation of $\mathbf{u}(\mathbf{x})$ is obtained from $\mathbf{u}(\mathbf{x}) = D^{-1}(\mathbf{j}(\mathbf{x}) - \mathbf{q}(\mathbf{x}))$ as follows:

$$\left(\begin{pmatrix} -2 & -10 & -4 \\ 3 & 24 & 9 \end{pmatrix}, \begin{pmatrix} 0 & 2 & 0 & -1 \\ 0 & -5 & 0 & 3 \end{pmatrix}, \begin{pmatrix} -6 \\ 15 \end{pmatrix}; \begin{pmatrix} 2 & 1 & 1 \\ -3 & -6 & -3 \\ 1 & 2 & 1 \\ -4 & -2 & -2 \end{pmatrix}, \begin{pmatrix} 1 & 0 & 0 & 0 \\ -1 & 1 & 0 & 0 \\ 0 & 0 & 1 & 0 \\ 0 & 0 & -5 & 1 \end{pmatrix}, \begin{pmatrix} 0 \\ -3 \\ 1 \\ 0 \end{pmatrix} \right).$$

4.6 Summary

In this chapter, we mentioned our research findings on the fundamental properties of the P-representation and the ULT-representation. In this research, we showed that Class ULT is closed under the operation of max and min composition, direct sum, composition, and linear combination. This result provides us numerous remarkable advantages in the transformation of representations, as well as the operation method among representations. As an application of this result, we proved that piecewise linear function can be characterized by the P-representation and the ULT-representation, and provided a method of constructing a ULT-representation. As an another application, we obtained the method of transforming a P-representation to a ULT-representation. The problem is that the obtained ULT-representation would, in generally, involve some redundancies.

Namely, we can eliminate some components from the complementarity vectors as demonstrated in Remark 4.4 of Section 4.4. In Chapter 5, we will discuss this reducibility by formulating the problem of finding a minimum dimensional representation, and describe our investigation on this issue.

Chapter 5

Minimization of the linear complementarity representation

In Section 4.4, we demonstrated the reducibility of the dimension of the complementarity vectors. In this chapter, we discuss the problem of finding a minimum dimensional representation, and explain our research findings on this issue. The problem formulation is described in Section 5.1. A general consideration on the minimization is discussed in Section 5.2. Since the general consideration would involve numerous difficulties, we restrict our attention to the ULT-representation for the simplicity of our argument on this issue. The key to our approach is that the minimum dimensionality can be characterized by the redundancies of the complementarity vectors. In this investigation, we survey the relation between the minimality and the redundancies. We also describe the relation among the redundancies, and introduce a concept concerning to a redundancy, called the ULT-reducibility. In Section 5.3, we survey a geometric structure of the complementarity vectors. The survey plays an important role in the investigation of Section 5.4. In Section 5.4, we discuss the difference between the P-minimization and the ULT-minimization. Section 5.5 is devoted to the summary of Chapter 5 and further directions of our study.

5.1 Problem formulation

We begin with some notations used in this chapter. For a positive integer k , we define the families of triplets \mathbb{A}^k and \mathbb{C}^k as follows:

$$\begin{aligned}\mathbb{A}^k &= \{(A, B, \mathbf{g}) \mid A \in \mathbb{R}^{m \times n}, B \in \mathbb{R}^{m \times k}, \mathbf{g} \in \mathbb{R}^m\}, \\ \mathbb{C}^k &= \{(C, D, \mathbf{h}) \mid C \in \mathbb{R}^{k \times n}, D \in \mathbb{R}^{k \times k}, \mathbf{h} \in \mathbb{R}^k\}.\end{aligned}$$

The family of all linear complementarity representations with k -dimensional complementarity vectors is denoted by $\mathbb{S}^k \triangleq \mathbb{A}^k \times \mathbb{C}^k$. By convention, we denote by $\mathbb{S}^0 = \{(A, \mathbf{g}) \mid A \in \mathbb{R}^{m \times n}, \mathbf{g} \in \mathbb{R}^m\}$ the family of all representations of linear functions. Then, $\mathbb{S} \triangleq \bigcup_{k \geq 0} \mathbb{S}^k$ expresses the family of all linear complementarity representations. Similarly, we denote by $\mathbb{S}_{\text{ULT}} = \bigcup_{k \geq 0} \mathbb{S}_{\text{ULT}}^k$ the family of all ULT-representations, where $\mathbb{S}_{\text{ULT}}^k$ is the family of all ULT-representations of the k -dimensional complementarity vectors. Note that $\mathbb{S}_{\text{ULT}}^0 = \mathbb{S}^0$.

Definition 5.1. Let $\mathcal{S} \in \mathbb{S}$ be given, and let k be a nonnegative integer. We say \mathcal{S} is k -dimensional if $\mathcal{S} \in \mathbb{S}^k$, denoted by $\dim(\mathcal{S})$.

Let f be an LCC. Then we denote by $\mathbb{S}(f)$ the family of all representations that characterize f . Similarly, we denote by $\mathbb{S}_{\text{ULT}}(f)$ the family of all ULT-representations of f . The minimization problem is formulated in the following.

Definition 5.2. Let $\mathcal{S} \in \mathbb{S}(f)$. Then \mathcal{S} is called a *minimum dimensional representation* (a minimum representation for short) of f if $\dim(\mathcal{S}) \leq \dim(\mathcal{T})$ for all $\mathcal{T} \in \mathbb{S}(f)$.

Problem 5.1. The *minimization problem* with respect to f consists of the following two requirements: For a given representation $\mathcal{S} \in \mathbb{S}(f)$,

- (a) determine whether or not \mathcal{S} is a minimum representation of f ;
- (b) find a minimum representation of f , when \mathcal{S} is not minimum.

Similarly, we can formulate the ULT-minimization problem.

Definition 5.3. Let $\mathcal{S} \in \mathbb{S}_{\text{ULT}}(f)$. Then \mathcal{S} is called a *minimum dimensional ULT-representation* (a minimum ULT-representation for short) of f if $\dim(\mathcal{S}) \leq \dim(\mathcal{T})$ for all $\mathcal{T} \in \mathbb{S}_{\text{ULT}}(f)$.

Problem 5.2. The *ULT-minimization problem* with respect to f consists of the following two requirements: For a given representation $\mathcal{S} \in \mathbb{S}_{\text{ULT}}(f)$,

- (a) determine whether or not \mathcal{S} is a minimum ULT-representation of f ;
- (b) find a minimum ULT-representation of f , when \mathcal{S} is not minimum.

Remark 5.1. In the same manner, we can formulate the P-minimization problem.

5.2 General consideration

In this section, we discuss reducibility condition to identify the minimum dimensionality for a given representation. In Subsection 5.2.1, we classify the redundancies of the

complementarity vectors to three types, and discuss about them. In Subsection 5.2.2, we introduce the ULT-reducibility condition, and discuss about it.

5.2.1 Reducibility of the complementarity vectors

We begin with the following three examples to discuss the reducibility. Each examples demonstrate different type of redundancies from one another.

Example 5.1. Let $\mathcal{S}_1 = (\mathcal{A}_1, \mathcal{C}_1)$ be the ULT-representation given by the following:

$$A_1 = \begin{pmatrix} 1 & 1 \end{pmatrix}, B_1 = \begin{pmatrix} 0 & 1 & 0 & 1 \end{pmatrix}, g_1 = 0, C_1 = \begin{pmatrix} -3 & -6 \\ -4 & -8 \\ 4 & 8 \\ 6 & 12 \end{pmatrix}, D_1 = \begin{pmatrix} 1 & 0 & 0 & 0 \\ 1 & 1 & 0 & 0 \\ 0 & 0 & 1 & 0 \\ 0 & 0 & 1 & 1 \end{pmatrix}, \mathbf{h}_1 = \begin{pmatrix} 0 \\ 0 \\ 0 \\ 0 \end{pmatrix}.$$

Then, we can easily verify that there exist the following relations among the components of the complementarity vectors $u_i(\mathbf{x})$ ($i = 1, 2, 3, 4$):

$$u_1(\mathbf{x}) = 3u_2(\mathbf{x}), u_3(\mathbf{x}) = 2u_4(\mathbf{x}), u_4(\mathbf{x}) = -2x_1 - 4x_2 + 2u_2(\mathbf{x}).$$

This would imply that the variables $u_1(\mathbf{x})$, $u_3(\mathbf{x})$, and $u_4(\mathbf{x})$ are omitted from \mathcal{S}_1 . Indeed, we can omit them from \mathcal{S}_1 , and hence we find that \mathcal{S}_1 reduces to the following ULT-representation \mathcal{S}'_1 :

$$A'_1 = \begin{pmatrix} -1 & -3 \end{pmatrix}, B'_1 = 3, g'_1 = 0, C'_1 = \begin{pmatrix} 1 & 2 \end{pmatrix}, D'_1 = 1, h'_1 = 0.$$

Example 5.2. Let $\mathcal{S}_2 = (\mathcal{A}_2, \mathcal{C}_2)$ be the ULT-representation given by the following:

$$A_2 = \begin{pmatrix} 1 & 1 \end{pmatrix}, B_2 = \begin{pmatrix} 0 & 1 \end{pmatrix}, g_2 = 0, C_2 = \begin{pmatrix} 1 & 2 \\ 2 & 1 \end{pmatrix}, D_2 = \begin{pmatrix} 1 & 0 \\ 0 & 1 \end{pmatrix}, \mathbf{h}_2 = \begin{pmatrix} 0 \\ 0 \end{pmatrix}.$$

Then, in this case, there is no relation between $u_1(\mathbf{x})$ and $u_2(\mathbf{x})$ as in Example 5.1. However, since the variable $u_2(\mathbf{x})$ is independently obtained from $u_1(\mathbf{x})$ and the variable $u_1(\mathbf{x})$ is vanished from the first formula of the original representation, we can omit $u_1(\mathbf{x})$ from \mathcal{S}_2 . Thus \mathcal{S}_2 reduces to the following one-dimensional ULT-representation \mathcal{S}'_2 :

$$A'_2 = \begin{pmatrix} 1 & 1 \end{pmatrix}, B'_2 = 1, g'_2 = 0, C'_2 = \begin{pmatrix} 2 & 1 \end{pmatrix}, D'_2 = 1, h'_2 = 0.$$

Example 5.3. Let $\mathcal{S}_3 = (\mathcal{A}_3, \mathcal{C}_3) \in \mathbb{S}_{\text{ULT}}^k$ be given. Suppose there exist a positive integer $k' < k$, a triplet $\mathcal{C}'_3 \in \mathbb{C}_{\text{ULT}}^{k'}$, and a matrix $E \in \mathbb{R}^{k \times k'}$ such that the solution $\mathbf{u}(\mathbf{x})$ to the derived LCP from \mathcal{C}_3 can be expressed as $\mathbf{u}(\mathbf{x}) = E\mathbf{u}'(\mathbf{x})$, where $\mathbf{u}'(\mathbf{x})$ is the solution to the derived LCP from \mathcal{C}'_3 . Then \mathcal{S}_3 reduces to the ULT-representation $\mathcal{S}'_3 = (\mathcal{A}'_3, \mathcal{C}'_3) \in \mathbb{S}_{\text{ULT}}^{k'}$, where $\mathcal{A}'_3 = (A_3, B_3E, \mathbf{g}_3)$ for $\mathcal{A}_3 = (A_3, B_3, \mathbf{g}_3)$.

As demonstrated above, there exist at least three types of redundancies:

- (i) Dependency among the components of the complementarity vectors (Example 5.1).
- (ii) The absence of the components of the complementarity vectors from the first formula caused by some columns of B being zero (Example 5.2).
- (iii) Representability of the original complementarity vectors by means of some lower-dimensional complementarity vectors (Example 5.3).

Clearly, the minimum dimensionality requires the absence of redundancies of the complementarity vectors. We therefore conclude that the problem of finding a minimum dimensional representation results in the problem of eliminating redundant components of the complementarity vectors. We conjecture that the redundancies would be covered by the above mentioned three types. However, it has not been proven yet. So far, we have investigated the redundancies of (i) and (iii), and found that the redundancy of (i) is equivalent to the generalization of (iii), called the ULT-reducibility. In the next subsection, we will explain about this investigation.

5.2.2 ULT-reducibility

Firstly, we define the ULT-reducibility that is a generalization of the redundancy (iii).

Definition 5.4. Two representations $\mathcal{S}, \mathcal{T} \in \mathbb{S}$ are said to be *equivalent* to each other, denoted by $\mathcal{S} \cong \mathcal{T}$, if there exists an LCC f such that $\mathcal{S}, \mathcal{T} \in \mathbb{S}(f)$.

Definition 5.5. Let $\mathcal{C} \in \mathbb{C}_{\text{ULT}}^k$. Then \mathcal{C} is said to be *ULT-reducible* if there exist a nonnegative integer $k' < k$, and a triplet $\mathcal{C}' \in \mathbb{C}_{\text{ULT}}^{k'}$ such that every representation containing \mathcal{C} is equivalent to a ULT-representation containing \mathcal{C}' [i.e., for every $\mathcal{A} \in \mathbb{A}^k$, there exists $\mathcal{A}' \in \mathbb{A}^{k'}$ such that $(\mathcal{A}, \mathcal{C}) \cong (\mathcal{A}', \mathcal{C}')$]. If not, it is said to be *ULT-irreducible*.

Remark 5.2. At first glance, the ULT-reducibility is seems to depend on m (since \mathcal{A} involves the number m in its definition). However, this condition is, indeed, independent from the value of m . Namely, for two different integers m_1 and m_2 , \mathcal{C} is ULT-reducible with respect to m_1 if and only if \mathcal{C} is ULT-reducible with respect to m_2 .

\mathcal{C}_3 in Example 5.3 is ULT-reducible. Moreover, by Theorem 5.1 below, \mathcal{C}_1 in Example 5.1 is also ULT-reducible. On the other hand, \mathcal{C}_2 in Example 5.2 is ULT-irreducible.

Proposition 5.1 is an immediate consequence of Definition 5.3 and Definition 5.5. This guarantees that the ULT-irreducibility of \mathcal{C} is necessary for a given representation to be

minimum dimensional. Example 5.2 is a counterexample for the sufficiency.

Proposition 5.1. *If $\mathcal{S} = (\mathcal{A}, \mathcal{C}) \in \mathbb{S}_{\text{ULT}}(f)$ is a minimum dimensional representation of f , then \mathcal{C} is ULT-irreducible.*

The following Theorem 5.1 shows that the redundancy of (i) and ULT-reducibility of \mathcal{C} is equivalent. The condition (S) in Theorem 5.1 expresses a dependency among the components of the complementarity vectors.

Lemma 5.1. *Let $(D, \mathbf{q}(\mathbf{x}))$ be the derived LCP from $(C, D, \mathbf{h}) \in \mathbb{C}_{\text{ULT}}^k$, where D is a P -matrix, and let $\mathbf{u}(\mathbf{x})$ be the unique solution to it. Then, each component $u_p(\mathbf{x})$ of $\mathbf{u}(\mathbf{x})$, where $p = 1, 2, \dots, k$, is a linear function of \mathbf{x} if and only if $u_p(\mathbf{x})$ is constant on \mathbb{R}^n .*

Proof. It is clear by the definition of the complementarity vectors. \square

Theorem 5.1. *Let k be a positive integer. Then $\mathcal{C} \in \mathbb{C}_{\text{ULT}}^k$ is ULT-reducible if and only if the solution $\mathbf{u}(\mathbf{x})$ to the derived LCP from \mathcal{C} satisfies the following condition:*

(S) *For some $p = 1, 2, \dots, k$, there exist $\{\lambda_i\}_{i < p} \subset \mathbb{R}$ and a linear function $l_p : \mathbb{R}^n \rightarrow \mathbb{R}$ such that*

$$u_p(\mathbf{x}) = \sum_{i < p} \lambda_i u_i(\mathbf{x}) + l_p(\mathbf{x}) \quad (\forall \mathbf{x} \in \mathbb{R}^n).$$

Proof. Let $\mathcal{C} \in \mathbb{C}_{\text{ULT}}^k$, and let $\mathbf{u}(\mathbf{x})$ be the solution to the derived LCP from \mathcal{C} .

Sufficiency: Suppose $p = 1$, then $u_1(\mathbf{x})$ is linear, and hence a constant $a \geq 0$ by Lemma 5.1. For $C = (\mathbf{c}_1^T, \dots, \mathbf{c}_k^T)^T$, $D = (d_{i,j})_{1 \leq i, j \leq k}$, and $\mathbf{h} = (h_i)_{i=1}^k$, define the triplet $\mathcal{C}' = (C', D', \mathbf{h}') \in \mathbb{C}_{\text{ULT}}^{k'}$, where $k' = k - 1$, $C' = (\mathbf{c}_2^T, \dots, \mathbf{c}_k^T)^T$, $D' = (d_{i,j})_{i, j \neq 1}$ and $\mathbf{h}' = (h_{i+1} + ad_{i+1,1})_{i=1}^{k'}$. Then, for each triplet $\mathcal{A} \in \mathbb{A}^k$, we can find a triplet $\mathcal{A}' \in \mathbb{A}^{k'}$ such that $(\mathcal{A}, \mathcal{C}) \cong (\mathcal{A}', \mathcal{C}')$. In a similar manner, we can find such \mathcal{C}' for $p > 1$. Therefore, we conclude that \mathcal{C} is ULT-reducible.

Necessity: Suppose \mathcal{C} is ULT-reducible. Choose the dimension of range space as $m = k$. Then there exist a number $k' < k$, $\mathcal{C}' \in \mathbb{C}_{\text{ULT}}^{k'}$ and $\mathcal{A}' = (A', B', \mathbf{g}') \in \mathbb{A}^{k'}$ such that

$$\mathbf{u}(\mathbf{x}) = B' \mathbf{u}'(\mathbf{x}) + l(\mathbf{x}) \quad (\forall \mathbf{x} \in \mathbb{R}^n),$$

where $l(\mathbf{x}) = A' \mathbf{x} + \mathbf{g}'$, and $\mathbf{u}'(\mathbf{x})$ is the solution to the derived LCP from \mathcal{C}' . Since $k' < k$, we have a nonzero vector $\boldsymbol{\lambda} \in \mathbb{R}^k$ such that $(B')^T \boldsymbol{\lambda} = \mathbf{0}$, and hence $\boldsymbol{\lambda}^T \mathbf{u}(\mathbf{x}) = \boldsymbol{\lambda}^T l(\mathbf{x})$. This implies that $\mathbf{u}(\mathbf{x})$ satisfies the condition (S). \square

5.3 Geometry of the complementarity vectors

In the preceding section, we discussed the reducibility conditions of the complementarity vectors in order to characterize the minimality of representations. The investigation of the preceding section has been performed in terms of purely algebraic manner. In turn, in this section we investigate the complementarity vectors in terms of geometric manner. The investigation utilizes the mathematical tools to survey a geometric structure of the complementarity vectors developed in the area of LCP (see e.g., Chapter 6 in [9] and Chapter 3 in [25]). Notice the investigation of this section is an experimental and preliminary study for discussing the minimization problem from numerous viewpoints. However, it is significantly advantageous us to understand the minimization problem in intuitively. Consequently, we expect that the investigation of this section will contribute to our future work. Throughout this section, we assume that k is a positive integer. Let a triplet $(C, D, \mathbf{h}) \in \mathbb{C}^k$ be given. Suppose the coefficient matrix D is a P-matrix.

Definition 5.6. For $\alpha \subset [k]$, we define the polyhedron $P(\alpha) \subset \mathbb{R}^k$ as follows:

$$P(\alpha) \triangleq \{\mathbf{x} \in \mathbb{R}^n \mid C^{-1}(\alpha)\mathbf{q}(\mathbf{x}) \geq \mathbf{0}\},$$

where $C(\alpha) \in \mathbb{R}^{k \times k}$ is called a *complementarity matrix* defined as follows [9]:

$$C_{.j}(\alpha) = \begin{cases} -D_{.j} & j \in \alpha, \\ I_{.j} & j \notin \alpha, \end{cases}$$

where $D_{.j}$ [resp. $I_{.j}$] express the j -th column of the matrix D [resp. I]. We denote by \mathcal{P} the family of all polyhedra as defined above, i.e., $\mathcal{P} \triangleq \{P(\alpha) \mid \alpha \subset [k]\}$. Clearly, $\bigcup \mathcal{P} = \mathbb{R}^n$. By definition, each $P(\alpha)$ is a convex set.

Theorem 5.2. The family \mathcal{P} satisfies the following conditions: For $P(\alpha), P(\alpha') \in \mathcal{P}$,

- (i) their intersection $P(\alpha) \cap P(\alpha')$ is a common face of them;
- (ii) if $\text{int } P(\alpha), \text{int } P(\alpha') \neq \emptyset$ and $P(\alpha) \neq P(\alpha')$, then $\text{int } P(\alpha) \cap \text{int } P(\alpha') = \emptyset$.

Proof. See Appendix B.4. □

Theorem 5.3. Let \mathcal{R} be a finite family of polyhedra in \mathbb{R}^n such that $\bigcup \mathcal{R} = \mathbb{R}^n$. Then for each $\mathbf{y} \in \mathbb{R}^n$, there exists $R \in \mathcal{R}$ such that $\mathbf{y} \in R$ and $\dim R = n$.

Proof. See Appendix B.5. □

Since the family \mathcal{P} defined in Definition 5.6 satisfies the condition $\bigcup \mathcal{P} = \mathbb{R}^n$, we have the following. This claims that \mathcal{P}_0 defined in Corollary 5.1 becomes a polyhedral partition in the sense of Definition 2.1.

Corollary 5.1. There exists a sub-family \mathcal{P}_0 of \mathcal{P} satisfying the following:

- (i) $\bigcup \mathcal{P}_0 = \mathbb{R}^n$,
- (ii) $\text{int } P \neq \emptyset$ for all $P \in \mathcal{P}_0$,
- (iii) for each $P, P' \in \mathcal{P}_0$, $P \neq P'$ implies $\text{int } P \cap \text{int } P' = \emptyset$.

We call \mathcal{P}_0 a *derived partition* from the triplet (C, D, \mathbf{h}) . Moreover, the triplet (C, D, \mathbf{h}) is called a *k-dimensional representation* of \mathcal{P}_0 .

Remark 5.3. By definition of \mathcal{P} , the number of regions in \mathcal{P} is at most 2^k , and thus the same is true for \mathcal{P}_0 . Therefore, we can say that every piecewise linear function with l regions in its domain requires at least $\lceil \log_2 l \rceil$ -dimensional complementarity vectors in order to express it as linear complementarity representation.

Example 5.4. Consider the polyhedral partition of \mathbb{R} in which the number of separating points is three. In this case, we can express all such partitions by two-dimensional triplet of which the coefficient D is ULT: Let the partition $\mathcal{P} = \{(-\infty, c_1], [c_1, c_2], [c_2, c_3], [c_3, \infty)\}$ of \mathbb{R} be given, where $c_1, c_2, c_3 \in \mathbb{R}$ and $c_1 < c_2 < c_3$. Then, for $d = (c_3 - c_1)/(c_2 - c_1)$, we can verify the following two-dimensional triplet becomes a representation of \mathcal{P} :

$$\mathcal{C} = \left(\begin{pmatrix} 1 \\ 1 \end{pmatrix}, \begin{pmatrix} 1 & 0 \\ d & 1 \end{pmatrix}, \begin{pmatrix} -c_2 \\ -c_3 \end{pmatrix} \right).$$

Proof. Let $q_1(x) = x - c_2$ and $q_2(x) = x - c_3$. Then by definition of d , we have $q_3(x) \triangleq dq_1(x) - q_2(x) = x - c_1$. Next we put $P_1 = (-\infty, c_1], P_2 = [c_1, c_2], P_3 = [c_2, c_3]$, and $P_4 = [c_3, \infty)$. Then P_1 can be expressed by means of the given triplet \mathcal{C} as follows:

$$P_1 = \{x \in \mathbb{R} \mid -q_1(x) \geq 0, -q_3(x) \geq 0\} = \left\{ x \in \mathbb{R} \mid \begin{pmatrix} -1 & 0 \\ -d & 1 \end{pmatrix}^{-1} \begin{pmatrix} q_1(x) \\ q_2(x) \end{pmatrix} \geq 0 \right\} = P(\{1\}).$$

Similarly we see that $P_2 = P(\{1, 2\})$, $P_3 = P(\{2\})$, and $P_4 = P(\emptyset)$. These imply that the triplet \mathcal{C} is a representation of the partition \mathcal{P} . \square

Example 5.5. Consider the partition of \mathbb{R}^2 , as in Figure 5.1, that contains three separating hyperplanes; one of them is full line, and the others are half line. In this case, we

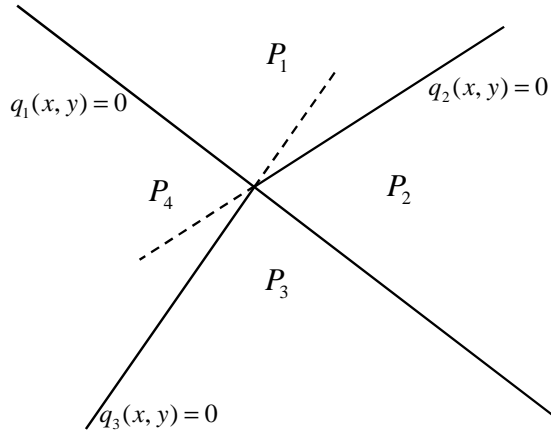

Figure 5.1: A partition of \mathbb{R}^2 with three separating hyperplanes

can represent all such partition by two-dimensional triplet of which D is ULT:

$$\mathcal{C} = \left(\begin{pmatrix} c_{11} & c_{12} \\ c_{21} & c_{22} \end{pmatrix}, \begin{pmatrix} 1 & 0 \\ -\lambda & 1 \end{pmatrix}, \begin{pmatrix} h_1 \\ h_2 \end{pmatrix} \right),$$

where $q_1(x, y) = c_{11}x + c_{12}y + h_1$, $q_2(x, y) = c_{21}x + c_{22}y + h_2$, and the coefficient λ will be given so that $q_3(x, y) = \lambda q_1(x, y) + q_2(x, y)$ is satisfied for all $(x, y) \in \mathbb{R}^2$.

Proof. It suffices to show that the triplet \mathcal{C} represent the polyhedral partition as in Figure 5.1. Since each hyperplane defined by q_i s meet at a common point, and the function q_1 and q_2 are linearly independent, there should be $\lambda \in \mathbb{R}$ such that $q_3 = \lambda q_1 + q_2$. Then we can verify that each P_i is expressed by means of the triplet \mathcal{C} . For example, P_1 is expressed as follows:

$$P_1 = \{(x, y) \mid q_1(x, y) \geq 0, q_2(x, y) \geq 0\} = \left\{ (x, y) \mid \begin{pmatrix} 1 & 0 \\ 0 & 1 \end{pmatrix}^{-1} \begin{pmatrix} q_1(x, y) \\ q_2(x, y) \end{pmatrix} \right\} = P(\emptyset).$$

Similarly, we have $P_2 = P(\{2\})$, $P_3 = P(\{1, 2\})$, and $P_4 = P(\{1\})$. \square

Example 5.6. Consider the partition of \mathbb{R}^2 , as in Figure 5.2, that contains four separating hyperplanes; all of them are half line. In this case, we can not represent all such partition by two-dimensional triplet of which D is ULT. However, it is possible to express this partition by two-dimensional triplet, when D is P:

$$\mathcal{C} = \left(\begin{pmatrix} c_{11} & c_{12} \\ c_{21} & c_{22} \end{pmatrix}, \begin{pmatrix} 1 & -\lambda_1 \\ -\lambda_2 & 1 \end{pmatrix}, \begin{pmatrix} h_1 \\ h_2 \end{pmatrix} \right),$$

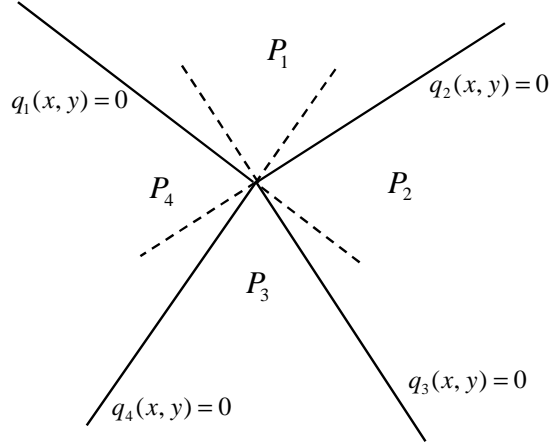

Figure 5.2: A partition of \mathbb{R}^2 with four separating hyperplanes

where $q_1(x, y) = c_{11}x + c_{12}y + h_1$, $q_2(x, y) = c_{21}x + c_{22}y + h_2$, and the coefficients λ_1, λ_2 will be given so that $1 > \lambda_1\lambda_2$ holds, and that $q_3(x, y) = q_1(x, y) + \lambda_1q_2(x, y)$ and $q_4(x, y) = \lambda_2q_1(x, y) + q_2(x, y)$ are satisfied for all $(x, y) \in \mathbb{R}^2$.

Proof. The first assertion: Based on the discussion in Example 5.5, the partition having a two-dimensional ULT-representation must be a type of partition of Figure 5.1, which contains at most three separating hyperplanes. However, the type of the partition as in this case differs from the type of Figure 5.1, that is, the partition contains four separating hyperplanes. Therefore, we conclude that the partition type of this example can not be represented in two-dimensional ULT-representation.

The second assertion: In the same way of Example 5.5, it suffices to show that the triplet \mathcal{C} becomes a representation of the partition as in Figure 5.2. For example, P_2 is expressed as follows:

$$P_2 = \{(x, y) \mid q_2(x, y) \leq 0, q_3(x, y) \geq 0\} = \left\{ (x, y) \mid \begin{pmatrix} 1 & \lambda_1 \\ 0 & -1 \end{pmatrix}^{-1} \begin{pmatrix} q_1(x, y) \\ q_2(x, y) \end{pmatrix} \right\} = P(\{2\}).$$

Similarly, we see that $P_1 = P(\emptyset)$, $P_3 = P(\{1, 2\})$, and $P_4 = P(\{1\})$. \square

The linear components of the complementarity vectors are given by the following.

Theorem 5.4. For each $\alpha \subset [k]$, it holds that $\mathbf{u}_\alpha(\mathbf{x}) = (C^{-1}(\alpha)\mathbf{q}(\mathbf{x}))_\alpha$ and $\mathbf{u}_{\bar{\alpha}}(\mathbf{x}) = \mathbf{0}$ for all $\mathbf{x} \in P(\alpha)$.

Proof. See Appendix B.6. \square

Corollary 5.2. The linear component $l : \mathbb{R}^n \rightarrow \mathbb{R}^k$ of the complementarity vector $\mathbf{u}(\mathbf{x})$ on each region $P(\alpha) \in \mathcal{P}_0$ is given by the following: $l_\alpha(\mathbf{x}) = (C^{-1}(\alpha)\mathbf{q}(\mathbf{x}))_\alpha$, $l_{\bar{\alpha}}(\mathbf{x}) = \mathbf{0}$.

5.4 Difference between the P-minimization and the ULT-minimization

In the previous section, we have investigated a geometry of the complementarity vectors, and provided a mathematical description of its feature as a piecewise linear function. In this section, we discuss a difference between the P-minimization and the ULT-minimization by means of this tool.

By definition, the number of parameters of the ULT-representation is smaller than the same dimensional P-representation owing to the lack of the upper triangular part of the coefficient matrix D . By the way, the coefficient matrix D generates the combination of hyperplanes used in the domain partition. This alludes that the number of functions having a ULT-representation is fewer than the number of functions having a same dimensional P-representations. Indeed, as shown in the following examples, there exists a function having a two-dimensional P-representation but not having two-dimensional ULT-representation.

Consider again the function f given in Example D.1. In the same procedure as in Example 4.1, the ULT-representation obtained from the right hand side of (D.2) is given by the following:

$$\left((0 \ 1), (0 \ -1 \ 1), 0; \begin{pmatrix} 0 & 1 \\ -2 & -2 \\ -1 & 2 \end{pmatrix}, \begin{pmatrix} 1 & 0 & 0 \\ 0 & 1 & 0 \\ 1 & -1 & 1 \end{pmatrix}, \begin{pmatrix} 0 \\ 0 \\ 0 \end{pmatrix} \right). \quad (5.1)$$

Observation 5.1. The representation (5.1) is a minimum ULT-representation for f .

Proof. The type of polyhedral partition of f is the same as in Example 5.6. Thus, f is not represented in two-dimensional ULT-representation. \square

On the one hand, f has a two-dimensional P-representation.

Observation 5.2. As we have explained in Observation 5.1, f has the three-dimensional minimum ULT-representation (5.1). However, in this case, we could take further reduction of the dimension. Namely, f has the following two-dimensional P-representation:

$$\left((1 \ -1), (3 \ -1), 0; \begin{pmatrix} 1 & 0 \\ 0 & 1 \end{pmatrix}, \begin{pmatrix} 1 & 1 \\ -1 & 1 \end{pmatrix}, \begin{pmatrix} 0 \\ 0 \end{pmatrix} \right). \quad (5.2)$$

Proof. It suffices to show that the regions P_i are represented by the following triplet

$$\mathcal{C} = \left(\begin{pmatrix} 1 & 0 \\ 0 & 1 \end{pmatrix}, \begin{pmatrix} 1 & 1 \\ -1 & 1 \end{pmatrix}, \begin{pmatrix} 0 \\ 0 \end{pmatrix} \right),$$

and the linear component on each region P_i obtained from the representation (5.2) coincides with g_i . For example, for $\alpha = \{1\}$, we see that

$$P(\{1\}) = \{(x, y) \mid C^{-1}(\{1\})\mathbf{q}(\mathbf{x}) \geq \mathbf{0}\} = \left\{ (x, y) \mid \begin{pmatrix} -1 & 0 \\ 1 & 1 \end{pmatrix}^{-1} \begin{pmatrix} x \\ y \end{pmatrix} \geq \mathbf{0} \right\} = P_4.$$

Moreover, on $P(\{1\})$ it holds that

$$C^{-1}(\{1\})\mathbf{q}(\mathbf{x}) = \begin{pmatrix} -x \\ x + y \end{pmatrix},$$

thus we have $\mathbf{u}(\mathbf{x}) = (-x, 0)^T$ on $P(\{1\})$. Hence

$$(1 \quad -1) \mathbf{x} + (3 \quad -1) \mathbf{u}(\mathbf{x}) + 0 = x - y + 3u_1(\mathbf{x}) = -2x - y = g_4(x, y).$$

Similarly, we see that $P(\emptyset) = P_1$, $P(\{2\}) = P_2$, and $P(\{1, 2\}) = P_3$, and on each P_i the linear component coincides with g_i . \square

From the above observation, we conclude that the P-minimization problem essentially differ from the ULT-minimization problem. In addition, it is clear that this difference concerns to the difference of structure of domain partition by comparing Example 5.5 and Example 5.6. This fact leads us to the following questions. They are future works:

(i) What condition allow us to reduce a given ULT-minimum representation to a P-minimum representation?

In connection with this,

(ii) can we see that transformability from the structure of the domain partition?

Moreover,

(iii) in order to study the P-minimization problem, can we use the same analysis technique discussed in Section 5.2?

5.5 Summary

In this chapter, we formulated the minimization problem of the linear complementarity representation, and described our study on the minimization problem. The current research findings in our study on this issue are as follows:

(i) We investigated the redundancies of the complementarity vectors in order to characterize the minimum dimensionality, and classified the redundancies of the complementarity vectors. In this investigation, we provided a concept of redundancies, the ULT-reducibility, and proved that the ULT-reducibility is equivalent to a kind of dependency among the components of the complementarity vectors (Theorem 5.1). It is a future work to clarify the relation between the ULT-minimum dimensionality and the redundancies introduced in Subsection 5.2.1.

(ii) We clarified a geometrical structure of the complementarity vectors, and provided a mathematical description of the vectors as a piecewise linear function, that is, a polyhedral partition and the linear components. The tool obtained in this investigation plays exceedingly an important role in the investigation of the geometrical structure of the complementarity vectors. To obtain further application of this tool is a future work.

(iii) We confirmed that the ULT-minimization problem essentially differ from the P-minimization problem through simple observations: Even though an obtained ULT-representation is minimum dimensional, there exists a case that we could find a lower-dimensional P-representation (Observation 5.2). Moreover, in connection with this fact, we presented new direction of our study.

Chapter 6

Conclusion

This thesis described our current research findings of fundamental properties of representations for piecewise linear functions.

First interest concerning to the representations is to clarify the relationships among representations. To this point, many researchers have already done on its own research on the relationships among several representations. In our study, we investigated the relationships among the three types of representations, Chua canonical form, the linear complementarity representation, and the max-min polynomial, and the Choquet integral as a piecewise linear function.

Second interest is the fundamental properties of representations. In spite of its high versatility, the study on the fundamental properties of the linear complementarity representation has not been performed enough. Motivated by this fact, we have investigated its fundamental properties. As a result of this, we found that two special types of this representation, called the P-representation and the ULT-representation, individually characterizes any piecewise linear functions. Moreover, we provided operation formulas between two ULT-representations, and yielded a construction method of a ULT-representation for a given piecewise linear function. Furthermore, we obtained a transformation method of each P-representation to a ULT-representation by means of the same formulas.

By the way, the linear complementarity representation, in generally, involves some redundancies. Motivated by this fact, we formulated the minimization problem on the linear complementarity representation, and investigated on this issue, under the restriction of our attention to the ULT-representation. In our study, we have investigated this problem from algebraic and geometric points of views. In algebraic aspect, based on the principle that the redundancies of representation are characterized by the redundancies of the com-

plementarity vectors, we classified the redundancies of the complementarity vectors, and discussed about them. As a result of this, we introduced a concept of redundancies, called the ULT-reducibility, and found that this property is equivalent to a kind of dependency among the components of the complementarity vectors. On the one hand, in geometric aspect, we provided a mathematical description of the complementarity vectors as a piecewise linear function, and found that the P-minimization problem differs essentially from the ULT-minimization problems by means of this tool. The tool obtained in this investigation is significantly advantageous us to understand the minimization problem in intuitively, and therefore we expect that this tool plays an important rule in our future work. Furthermore, as a future work, we will investigate the minimization problem under a given approximation accuracy, from the practical point of view.

Bibliography

- [1] C. D. Aliprantis and R. Tourky, *Cones and Duality*, AMS, (2007).
- [2] E. L. Allgower and K. Georg, Piecewise linear methods for nonlinear equations and optimization, *J. Comput. Appl. Math.*, Vol.124 (2000) 245–261.
- [3] W. M. G. van Bokhoven and D. M. W. Leenaerts, Explicit formulas for the solutions of piecewise linear networks, *IEEE Trans. Circuits Systems I Fund. Theory Appl.*, Vol.46, No.9 (1999) 1110–1117.
- [4] J. L. Bryant, Piecewise linear topology, in R. J. Daverman and R. B. Sher (ed.), *Handbook of geometric topology*, Elsevier Science B. V., (2002).
- [5] H. W. Buurman, *From circuit to signal, development of a piecewise linear simulator*, Ph.D. dissertation, Technical University of Eindhoven, (1993).
- [6] S. D. Cairano and A. Bemporad, Equivalent piecewise affine models of linear hybrid automata, *IEEE trans. Automatic Control*, Vol.55, No.2 (2010) 498–502.
- [7] L. O. Chua and S. M. Kang, Section-wise piecewise-linear functions: canonical representation, properties, and applications, *Proc. of The IEEE*, Vol.65, No.6 (1977).
- [8] L. O. Chua and A.-C. Deng, Canonical piecewise linear representation, *IEEE Trans. Circuits Systems I Fund. Theory Appl.*, Vol.35, No.1 (1988) 101–111.
- [9] R. W. Cottle, J.-S. Pang, and R. E. Stone, *The Linear Complementarity Problem*, Academic Press, (1992).
- [10] J. T. J. Eijndhoven, Piecewise linear analysis, in T. Ozawa (ed.), *Analog methods for computer-aided circuit analysis and diagnosis 1*, Marcel Dekker, New York, (1988).

- [11] V. V. Gorokhovich and O. I. Zorko, Piecewise affine functions and polyhedral sets, *Optimization*, Vol.31 (1994) 209–221.
- [12] M. Grabisch, T. Murofushi, and M. Sugeno, eds., *Fuzzy measures and integrals: Theory and Applications*, Physica, Heidelberg, 2000.
- [13] W. P. M. H. Heemels, B. D. Schutter and A. Bemporad, Equivalence of hybrid dynamical models, *Automatica*, Vol.31 (2001) 1085–1091.
- [14] W. P. M. H. Heemels, J. M. Schumacher and S. Weiland, Linear complementarity systems, *SIAM J. Appl. Math.*, Vol.60, No.4 (2000) 1234–1269.
- [15] M. Johansson, *Piecewise Linear Control Systems: A computational approach*, Lecture Notes in Control and Information Sciences 284, Springer, (2003).
- [16] P. Julián, *A high level canonical piecewise linear representation: Theory and applications*, Ph.D. dissertation, Universidad National del Sur, (1999).
- [17] P. Julián, The complete canonical piecewise-linear representation: functional form for minimal degenerate intersections, *IEEE trans. Circuits Systems I Fund. Theory Appl.*, Vol.50, No.3, (2003) 387–396.
- [18] M. Komuro, Bifurcation equations and standard forms of continuous piecewise-linear vector fields, in M. Yamaguchi (ed.), *Towards the Harnessing of Chaos*, Elsevier, (1994).
- [19] T. A. Kevenaar, D. M. W. Leenaerts, and W. M. G. van Bokhoven, Extensions to Chua’s explicit piecewise-linear function descriptions, *IEEE trans. Circuits Systems I Fund. Theory Appl.*, Vol.41, No.4 (1994) 308–314.
- [20] D. M. W. Leenaerts, Further extensions to Chua’s explicit piecewise linear function descriptions, *Int J. Circuit Theory Appl.*, Vol.24 (1996) 621–633.
- [21] D. M. W. Leenaerts and W. M. G. van Bokhoven, *Piecewise Linear Modeling and Analysis*, Kluwer, Boston (1998).
- [22] J.-N. Lin, H.-Q. Xu, R. Unbehauen, A generalization of canonical piecewise-linear functions, *IEEE Trans. Circuits and Systems I*, Vol.41, No.4 (1994) 345–347.

- [23] T. Murofushi, M. Sugeno, and M. Machida, Non-monotonic fuzzy measures and the Choquet integral, *Fuzzy Sets and Systems*, Vol.64, No.1 (1994) 73–86.
- [24] T. Murofushi and Y. Narukawa, A characterization of multi-step discrete Choquet integral, *6th International Conference on Fuzzy Sets Theory and Its Applications, Abstracts*, (FSTA 2002) p. 94.
- [25] K. G. Murty and F.-T. Yu, *Linear complementarity, linear and nonlinear programming*, Helderman-Verlag (1988).
- [26] Y. Narukawa and T. Murofushi, The n-step Choquet integral on finite spaces, *Proc. 9th Intern. Conf. Information Processing and Management of Uncertainty in Knowledge-based Systems*, (IPMU 2002) 539–543.
- [27] S. Ovchinnikov, Piecewise linear aggregation functions, *Int. J. Uncertainty, Fuzziness and Knowledge-Based Systems*, Vol.10, No.1 (2002) 17–24.
- [28] S. Ovchinnikov, Max-min representation of piecewise linear functions, *Contributions to Algebra and Geometry*, Vol.43, No.1 (2002) 297–302.
- [29] N. B. O. L. Pettit, *Analysis of Piecewise Linear Dynamical Systems*, Research Studies Press Ltd., (1995).
- [30] R. T. Rockafellar, *Convex analysis*, Princeton University Press, (1970).
- [31] T. Sakurai and T. Murofushi, The Choquet integral as a piecewise linear function and Chua’s canonical form, *Proc. Joint 2nd Int. Conf. Soft Comp. & Intell. Syst. and 5th Int. Symp. Adv. Intell. Syst.*, (SCIS & ISIS 2004) FA-1-2.
- [32] T. Sakurai and T. Murofushi, Linear complementarity representation of piecewise linear functions, submitted.
- [33] J. Shen and J. S. Pang, Linear Complementarity Systems: Zeno States, *SIAM Journal on Control and Optimization*, Vol.44, No.3, (2005), 1040–1066.
- [34] J. Shen and J. S. Pang, Semicopositive Linear Complementarity Systems, *International Journal of Robust and Nonlinear Control*, Vol.17, No.15, (2007), 1367-1386.
- [35] G. F. Simmons, *Introduction to topology and modern analysis*, McGraw-Hill, (1963).

- [36] J. Stoer, C. Witzgall, *Convexity and optimization in finite dimensions I*, Springer-Verlag, (1970).
- [37] J. M. Tarela, J. M. Perez, and V. Aleixandre, Minimization of lattice polynomials on piecewise linear functions (Part I), *Mathematics and Computers in Simulation*, Vol.17, No.2, (1975) 79–85.
- [38] J. M. Tarela, L. A. Bailon, and E. Sanz G., Minimization of lattice polynomials on piecewise linear functions (Part II), *Mathematics and Computers in Simulation*, Vol.17, No.2, (1975) 121–127.
- [39] J. M. Tarela, E. Alonso, and M. V. Martinez, A representation method for pwl function oriented to parallel processing, *Mathl. Comput. Modelling*, Vol.13, No.10, (1990) 75–83.
- [40] C. Wen, S. Wang, F. Li and M. J. Khan, A compact f - f model of high-dimensional piecewise-linear function over a degenerate intersection, *IEEE Trans. Circuits and Systems I*, Vol.52 No.4, (2005) 815–821.
- [41] C. A. Yfoulis, *Stabilisation of Nonlinear Systems: the piecewise linear approach*, Reserach Studies, (2001).
- [42] P. B. Zwart, Multivariate splines with nondegenerate partitions, *SIAM J. Numer. Anal.*, Vol.10, No.4 (1973) 665–673.

Appendix A

Fundamentals

A.1 Convex analysis essence

Definition A.1. [30, 36] Let $C \subset \mathbb{R}^n$ be given. Then C is called a *convex set* if for any $\mathbf{x}, \mathbf{y} \in C$ and any $\lambda \in (0, 1)$, we have $\lambda\mathbf{x} + (1 - \lambda)\mathbf{y} \in C$.

Definition A.2. [30, 36] Let P be a convex set in \mathbb{R}^n . Then an inequality $\langle \mathbf{a}, \mathbf{x} \rangle \leq b$, where $\mathbf{a} \in \mathbb{R}^n$ and $b \in \mathbb{R}$, is said to be *valid* for P if $\langle \mathbf{a}, \mathbf{x} \rangle \leq b$ holds for all $\mathbf{x} \in P$.

Let P be a convex polyhedron in \mathbb{R}^n , and let $F \subset P$ be given.

Definition A.3. [30, 36] F is called a *face* of P if there exists a valid inequality $\langle \mathbf{a}, \mathbf{x} \rangle \leq b$ for P such that $F = P \cap \{\mathbf{x} \mid \langle \mathbf{a}, \mathbf{x} \rangle = b\}$. P is itself a face of P . A face $F \subset P$ is said to be *proper* if $F \neq P$.

For a hyperplane $H = \{\mathbf{x} \mid \langle \mathbf{a}, \mathbf{x} \rangle = b\}$, where $\mathbf{a} \in \mathbb{R}^n \setminus \{\mathbf{0}\}$ and $b \in \mathbb{R}$, the two subsets of \mathbb{R}^n defined by $H_+ = \{\mathbf{x} \mid \langle \mathbf{a}, \mathbf{x} \rangle \leq b\}$ and $H_- = \{\mathbf{x} \mid \langle \mathbf{a}, \mathbf{x} \rangle \geq b\}$ are called the half-spaces.

Definition A.4. [30, 36] Let $C \subset \mathbb{R}^n$ be a nonempty convex set, and let $H \subset \mathbb{R}^n$ be a hyperplane.

- (i) H is called a *supporting hyperplane* of C if $C \subset H_+$ (or $C \subset H_-$) and $C \cap H \neq \emptyset$ hold.
- (ii) A supporting hyperplane H of C is said to be *nontrivial* if $C \not\subset H$ holds.

Theorem A.1. [30, 36] *Let $C \subset \mathbb{R}^n$ be a nonempty convex set, and let $D \subset C$ be a nonempty convex subset. Then there exists a nontrivial supporting hyperplane $H \subset \mathbb{R}^n$ of C containing D if and only if D contains no relative interior point of C .*

Remark A.1. See e.g., [35] for the definition of relative interior.

Theorem A.2. *Let P be a nonempty convex polyhedron, and let $\emptyset \neq F \subset P$ be given. Then F is a proper face of P if and only if F contains no relative interior point of P .*

Proof. By Theorem A.1, it suffices to show that the properness of F is equivalent to the existence of nontrivial supporting hyperplane for P containing F . Let $F = P \cap H$, where $H = \{\mathbf{x} \in \mathbb{R}^n \mid \langle \mathbf{a}, \mathbf{x} \rangle = b\}$ is a hyperplane, and $\langle \mathbf{a}, \mathbf{x} \rangle \leq b$ is valid for P . Since F is nonempty, H becomes a supporting hyperplane of P . If F is proper, there exists a point $\mathbf{x} \in P$ not contained in F . This point is also not contained in H . Thus H is non-trivial. Conversely, if H is non-trivial, there exists a point $\mathbf{x} \in P$ not contained in H . By definition of H , F does not contain \mathbf{x} , namely, $F \neq P$. Therefore, F is proper. \square

Definition A.5. [36] F is called an *extreme subset* of P if for any $\mathbf{x}, \mathbf{y} \in P$, $(\mathbf{x}, \mathbf{y}) \cap F \neq \emptyset$ implies $\mathbf{x}, \mathbf{y} \in F$, where $(\mathbf{x}, \mathbf{y}) \triangleq \{\lambda \mathbf{x} + (1 - \lambda) \mathbf{y} \mid \lambda \in (0, 1)\}$.

Theorem A.3. [36] F is a face of P if and only if F is an extreme subset of P .

A.2 The linear complementarity problem

Let k be a positive integer.

Definition A.6. ([9]) Given a matrix $D \in \mathbb{R}^{k \times k}$ and a vector $\mathbf{q} \in \mathbb{R}^k$, a *linear complementarity problem*, LCP for short, is to find a pair of vectors $\mathbf{u}, \mathbf{j} \in \mathbb{R}^k$ such that

$$\mathbf{j} = D\mathbf{u} + \mathbf{q}, \tag{A.1}$$

$$\mathbf{u}, \mathbf{j} \geq \mathbf{0}, \langle \mathbf{u}, \mathbf{j} \rangle = 0 \tag{A.2}$$

or to show that no such pair exists. We denote the above problem by the pair (D, \mathbf{q}) . A pair (\mathbf{u}, \mathbf{j}) satisfying (A.2) is said to be complementary, and the one satisfying (A.1) and (A.2) is called a solution to the LCP (D, \mathbf{q}) .

Next, we will introduce two kinds of matrices in relation with a representation of piecewise linear function.

Definition A.7. (i) ([9]) *P-matrix* is a square matrix whose principal minors are all positive.

(ii) ([19]) *Unit lower triangular matrix*, ULT-matrix for short, is a lower triangular matrix whose diagonal elements are all one's.

Remark A.2. A principal minor is the determinant of a principal sub-matrix of D , and a principal sub-matrix is formed by deleting exactly the same members of rows and columns from the original matrix. It is easy to see that every ULT-matrix is a P-matrix.

In general, the LCP does not necessarily have a solution. Even if it has a solution, generally it is not necessarily unique. However, Proposition A.1 below claims that a P-matrix guarantees the uniqueness of solution.

Proposition A.1. [9] *A matrix $D \in \mathbb{R}^{k \times k}$ is a P-matrix if and only if the LCP (D, \mathbf{q}) has a unique solution for every $\mathbf{q} \in \mathbb{R}^k$.*

By Proposition A.1, if D is a P-matrix, then the pair of vectors \mathbf{u} and \mathbf{j} satisfying (A.1) and (A.2) is uniquely determined. In such a case, we often refer to \mathbf{u} (or \mathbf{j}) as “the unique solution to (D, \mathbf{q}) ”, without confusion.

Remark A.3. When the matrix D is nonsingular, we can define the LCP $(D^{-1}, -D^{-1}\mathbf{q})$ for each $\mathbf{q} \in \mathbb{R}^k$. Then (\mathbf{u}, \mathbf{j}) is a solution to (D, \mathbf{q}) if and only if (\mathbf{j}, \mathbf{u}) is a solution to $(D^{-1}, -D^{-1}\mathbf{q})$. Moreover, by Proposition A.1, if D is a P-matrix, then the unique solution to (D, \mathbf{q}) is also the unique solution to $(D^{-1}, -D^{-1}\mathbf{q})$. Thus, we obtain the following proposition.

Proposition A.2. *The inverse of a P-matrix is also a P-matrix.*

Remark A.4. For a one-dimensional LCP (d, q) (i.e., d is a positive number), we can easily obtain the solution as follows:

$$u = \left(-\frac{q}{d}\right)^+, \quad j = q^+.$$

A.3 Complementarity cone

Let k be a positive integer. For a matrix $A \in \mathbb{R}^{k \times l}$, and $\alpha \subset [l]$, we write by A_α a submatrix of A consisting of the columns of A indexed by α .

Definition A.8. [30, 36] Let $C \subset \mathbb{R}^k$ be given. Then C is called a *cone* if for any $\mathbf{x} \in C$ and for any $t \geq 0$, we have $t\mathbf{x} \in C$. A cone which is a convex polyhedron is called a *convex polyhedral cone*.

Definition A.9. [9] For a matrix $A \in \mathbb{R}^{k \times l}$, the cone defined by $\text{pos } A = \{A\mathbf{t} \mid \mathbf{t} \in \mathbb{R}^l, \mathbf{t} \geq \mathbf{0}\}$ is called a *finitely generated cone*.

Remark A.5. [9] Every finitely generated cone becomes a convex polyhedral cone.

Let $D \in \mathbb{R}^{k \times k}$ be given.

Definition A.10. [9] For a complementarity matrix $C(\alpha) \in \mathbb{R}^{k \times k}$ of D , where $\alpha \subset [k]$, the cone $\text{pos } C(\alpha)$ is called a *complementarity cone* of D .

Lemma A.1. If D is a P-matrix, then for any $\alpha, \alpha' \subset [k]$, it holds that $\text{pos } C(\alpha) \cap \text{pos } C(\alpha') = \text{pos } C(\alpha)_{\overline{\alpha \Delta \alpha'}}$.

Proof. Let $F \triangleq \text{pos } C(\alpha) \cap \text{pos } C(\alpha')$ be defined.

In the case of $\overline{\alpha \Delta \alpha'} = \emptyset$: We show $F = \{\mathbf{0}\}$. By contradiction. Suppose there exists a non zero vector $\mathbf{q} \in F$. By definition of F , there exist non zero vectors $\boldsymbol{\mu}, \boldsymbol{\nu} \in \mathbb{R}^k$ such that $\boldsymbol{\mu}, \boldsymbol{\nu} \geq \mathbf{0}$ and $\mathbf{q} = C(\alpha)\boldsymbol{\mu} = C(\alpha')\boldsymbol{\nu}$. Then we have

$$\begin{pmatrix} \mathbf{0}_\alpha \\ \boldsymbol{\mu}_{\overline{\alpha}} \end{pmatrix} = D \begin{pmatrix} \boldsymbol{\mu}_\alpha \\ \mathbf{0}_{\overline{\alpha}} \end{pmatrix} + \mathbf{q}, \quad \begin{pmatrix} \mathbf{0}_{\alpha'} \\ \boldsymbol{\nu}_{\overline{\alpha'}} \end{pmatrix} = D \begin{pmatrix} \boldsymbol{\nu}_{\alpha'} \\ \mathbf{0}_{\overline{\alpha'}} \end{pmatrix} + \mathbf{q}. \quad (\text{A.3})$$

Now, $\overline{\alpha \Delta \alpha'} = \emptyset$ implies $\alpha \cap \alpha' = \emptyset$ and $\alpha \cup \alpha' = [k]$, we have $\alpha = \overline{\alpha'}$ and $\alpha' = \overline{\alpha}$. Moreover, since D is a P-matrix, the solution to the LCP (D, \mathbf{q}) is unique. Thus we obtain that $\boldsymbol{\mu}_\alpha = \mathbf{0}_{\overline{\alpha'}}$, $\boldsymbol{\mu}_{\overline{\alpha}} = \mathbf{0}_{\alpha'}$, $\boldsymbol{\nu}_{\alpha'} = \mathbf{0}_{\overline{\alpha}}$, and $\boldsymbol{\nu}_{\overline{\alpha'}} = \mathbf{0}_\alpha$, namely, $\boldsymbol{\mu} = \boldsymbol{\nu} = \mathbf{0}$. This is a contradiction.

In the case of $\overline{\alpha \Delta \alpha'} \neq \emptyset$: We may assume that $\alpha \Delta \alpha' \neq \emptyset$ (If $\alpha \Delta \alpha' = \emptyset$, we have $\alpha = \alpha'$ and $\overline{\alpha \Delta \alpha'} = [k]$). In this case, the objective equation is clear). It is clear the set inclusion $\text{pos } C_{\overline{\alpha \Delta \alpha'}}(\alpha) \subset F$. Then we show the inverse inclusion. Let $\mathbf{q} \in F$ be given. By definition of F , there exist vectors $\boldsymbol{\mu}, \boldsymbol{\nu} \in \mathbb{R}^k$ such that $\boldsymbol{\mu}, \boldsymbol{\nu} \geq \mathbf{0}$ and $\mathbf{q} = C(\alpha)\boldsymbol{\mu} = C(\alpha')\boldsymbol{\nu}$. Then we have

$$\begin{pmatrix} \mathbf{0}_\alpha \\ \boldsymbol{\mu}_{\overline{\alpha}} \end{pmatrix} = D \begin{pmatrix} \boldsymbol{\mu}_\alpha \\ \mathbf{0}_{\overline{\alpha}} \end{pmatrix} + \mathbf{q}, \quad \begin{pmatrix} \mathbf{0}_{\alpha'} \\ \boldsymbol{\nu}_{\overline{\alpha'}} \end{pmatrix} = D \begin{pmatrix} \boldsymbol{\nu}_{\alpha'} \\ \mathbf{0}_{\overline{\alpha'}} \end{pmatrix} + \mathbf{q}. \quad (\text{A.4})$$

Since D is a P-matrix, the solution to the LCP (D, \mathbf{q}) is unique. Thus we obtain that $\boldsymbol{\mu}_{\alpha \Delta \alpha'} = \boldsymbol{\nu}_{\alpha \Delta \alpha'} = \mathbf{0}$. Therefore $\mathbf{q} \in \text{pos } C_{\overline{\alpha \Delta \alpha'}}(\alpha)$ holds. \square

Lemma A.2. If D is a P-matrix, then for any $\alpha, \alpha' \subset [k]$ and $\boldsymbol{\mu}, \boldsymbol{\nu} \in \mathbb{R}^k$ satisfying $\boldsymbol{\mu} \geq \mathbf{0}$ and $\boldsymbol{\nu} \geq \mathbf{0}$, $C(\alpha)\boldsymbol{\mu} = C(\alpha')\boldsymbol{\nu}$ implies $\boldsymbol{\mu} = \boldsymbol{\nu}$, especially $\boldsymbol{\mu}_{\alpha \Delta \alpha'} = \boldsymbol{\nu}_{\alpha \Delta \alpha'} = \mathbf{0}$.

Proof. Let $\alpha, \alpha' \subset [k]$ and $\boldsymbol{\mu}, \boldsymbol{\nu} \in \mathbb{R}^k$ satisfying $\boldsymbol{\mu} \geq \mathbf{0}$ and $\boldsymbol{\nu} \geq \mathbf{0}$ be given. Suppose $C(\alpha)\boldsymbol{\mu} = C(\alpha')\boldsymbol{\nu}$ holds. Then by Lemma A.1, it holds that $C(\alpha)\boldsymbol{\mu}, C(\alpha')\boldsymbol{\nu} \in \text{pos } C(\alpha) \cap \text{pos } C(\alpha') = \text{pos } C(\alpha)_{\overline{\alpha \Delta \alpha'}}$. Since the columns of $C(\alpha)$ are linearly independent, we have $\boldsymbol{\mu}_{\alpha \Delta \alpha'} = \mathbf{0}$. Similarly we have $\boldsymbol{\nu}_{\alpha \Delta \alpha'} = \mathbf{0}$. Thus we obtain the following equation:

$$C(\alpha)_{\overline{\alpha \Delta \alpha'}}(\boldsymbol{\mu}_{\overline{\alpha \Delta \alpha'}} - \boldsymbol{\nu}_{\overline{\alpha \Delta \alpha'}}) = \mathbf{0}.$$

Since the columns of $C(\alpha)_{\alpha\Delta\alpha'}$ are linearly independent, this implies that $\boldsymbol{\mu}_{\alpha\Delta\alpha'} - \boldsymbol{\nu}_{\alpha\Delta\alpha'} = \mathbf{0}$, and hence that $\boldsymbol{\mu}_{\alpha\Delta\alpha'} = \boldsymbol{\nu}_{\alpha\Delta\alpha'}$. Consequently we obtain $\boldsymbol{\mu} = \boldsymbol{\nu}$. \square

A.4 Nowhere density in \mathbb{R}^n

Definition A.11. [35] A set $A \subset \mathbb{R}^n$ is said to be *nowhere dense* if $\text{int cl } A = \emptyset$.

Lemma A.3. When two sets $A, B \subset \mathbb{R}^n$ are nowhere dense, so is $A \cup B$.

Proof. Suppose $\text{int cl } A = \emptyset$ and $\text{int cl } B = \emptyset$. We show that $\text{int cl } (A \cup B) = \emptyset$ holds. By contradiction. We may assume that $\text{int cl } (A \cup B) \neq \emptyset$, then there exists a nonempty open subset G of $\text{int cl } (A \cup B)$. By definition of the topological interior, it holds that $G \subset \text{cl } (A \cup B) = \text{cl } A \cup \text{cl } B$. Thus we have $G \setminus \text{cl } B \subset \text{cl } A \setminus \text{cl } B \subset \text{cl } A$. Since $\text{int cl } A = \emptyset$, $G \setminus \text{cl } B = \emptyset$ holds. Thus, we obtain $G \subset \text{cl } B$, and hence $\text{int cl } B \neq \emptyset$. Similarly, we have $\text{int cl } A \neq \emptyset$. These are contradictions. \square

Lemma A.4. There exists an infinite sequence $\{\mathbf{e}_l\}_{l=1}^{\infty}$ in \mathbb{R}^n satisfying the following:

- (i) For all positive integer $l \geq 1$, $\|\mathbf{e}_l\| \leq \frac{1}{l}$, where $\|\cdot\|$ denotes a norm on \mathbb{R}^n .
- (ii) Arbitrary n elements of $\{\mathbf{e}_l\}_{l=1}^{\infty}$ are linearly independent.

Proof. By induction on l . Notice that \mathbb{R}^n contains an n elements sequence which is linearly independent. Moreover, we may assume that this sequence satisfies the condition (i) by taking appropriate scaling. Suppose, for l , we obtain a sequence $\{\mathbf{e}_i\}_{i=1}^l$ satisfying (i) and (ii). Define the finite family of $(n-1)$ -dimensional linear subspaces generated by $\{\mathbf{e}_i\}_{i=1}^l$ as follows:

$$\mathcal{H} = \left\{ \text{lin} \{ \mathbf{e}_{i_j} \}_{j=1}^{n-1} \mid \mathbf{e}_{i_j} \in \{ \mathbf{e}_i \}_{i=1}^l, i_1 < i_2 < \dots < i_{n-1} \right\},$$

where $\text{lin} \{ \mathbf{e}_{i_j} \}_{j=1}^{n-1}$ denotes the smallest linear subspace in \mathbb{R}^n containing $\{ \mathbf{e}_{i_j} \}_{j=1}^{n-1}$. Since each linear subspace in \mathcal{H} is nowhere dense, so is $\bigcup \mathcal{H}$ by Lemma A.3, that is, $\text{int cl } \bigcup \mathcal{H} = \emptyset$. Thus we can obtain a vector $\mathbf{e}_{l+1} \in S_{\frac{1}{l+1}}(\mathbf{0}) \setminus \bigcup \mathcal{H}$. In this time, we can easily verify that the sequence $\{\mathbf{e}_i\}_{i=1}^{l+1}$ satisfies (i) and (ii). \square

Appendix B

Proofs

B.1 Proof of Theorem 2.1

Definition 2.2 implies Definition 2.5 Let $f : \mathbb{R}^n \rightarrow \mathbb{R}^m$ be a piecewise linear function, and let \mathcal{R} be a polyhedral partition of \mathbb{R}^n such that f is linear on each region $R \in \mathcal{R}$. Then, since each region is a polyhedron, there exists a finite collection of hyperplanes $\{(\boldsymbol{\alpha}_i; \beta_i)\}_{i=1}^l$ such that each region $R \in \mathcal{R}$ is specified by some elements of $\{(\boldsymbol{\alpha}_i; \beta_i)\}_{i=1}^l$. Moreover, we can choose the above collection so that each hyperplane does not agree with one another (i.e., $\{(\boldsymbol{\alpha}_i; \beta_i)\}_{i=1}^l$ satisfies the condition (lp) of Definition 2.3). In that situation, we can easily show that the family of regions \mathcal{R}' generated by $\{(\boldsymbol{\alpha}_i; \beta_i)\}_{i=1}^l$ satisfies the following conditions (the conditions imply that f is piecewise linear in the sense of Definition 2.5):

- (i) For each $R' \in \mathcal{R}'$, there exists $R \in \mathcal{R}$ such that $R' \subset R$,
- (ii) f is linear on each $R' \in \mathcal{R}'$: This follows from (i) and the linearity of f on each $R \in \mathcal{R}$.

Definition 2.5 implies Definition 2.2 Let $f : \mathbb{R}^n \rightarrow \mathbb{R}^m$ be a piecewise linear function, and let $\{(\boldsymbol{\alpha}_i; \beta_i)\}_{i=1}^l$ be a linear partition of \mathbb{R}^n satisfying the condition (pwl) of Definition 2.5. Then, in this situation, we can show that the family of regions \mathcal{R} generated by $\{(\boldsymbol{\alpha}_i; \beta_i)\}_{i=1}^l$ is a polyhedral partition in the sense of Definition 2.1 (This implies that f is piecewise linear in the sense of Definition 2.2):

Condition (i): It suffices to show the existence of $R_I \in \mathcal{R}$ satisfying $\boldsymbol{x} \in R_I$ to each $\boldsymbol{x} \in \mathbb{R}^n$. Let $\boldsymbol{x} \in \mathbb{R}^n$ be given, and let $I = \{i \in [l] \mid \langle \boldsymbol{\alpha}_i, \boldsymbol{x} \rangle \geq \beta_i\}$. Since $\{(\boldsymbol{\alpha}_i; \beta_i)\}_{i=1}^l$ satisfies the

condition (lp) of Definition 2.3, the dimension of polyhedron defined by

$$R = \{\mathbf{x} \in \mathbb{R}^n \mid \langle \boldsymbol{\alpha}_i, \mathbf{x} \rangle \geq \beta_i \ (\forall i \in I), \langle \boldsymbol{\alpha}_i, \mathbf{x} \rangle \leq \beta_i \ (\forall i \notin I)\}$$

is n . Namely $R = R_I \in \mathcal{R}$. This implies $\mathbf{x} \in R_I \subset \bigcup \mathcal{R}$.

Condition (ii): It is clear by the definition of \mathcal{R} .

Condition (iii): Let $R_I, R_J \in \mathcal{R}$ be given. Suppose $R_I \neq R_J$, and hence $I \neq J$. Without loss of generality we assume $I \setminus J \neq \emptyset$. Then, for $i \in I \setminus J$, it holds that $R_I \subset \{\mathbf{x} \in \mathbb{R}^n \mid \langle \boldsymbol{\alpha}_i, \mathbf{x} \rangle \geq \beta_i\}$ and $R_J \subset \{\mathbf{x} \in \mathbb{R}^n \mid \langle \boldsymbol{\alpha}_i, \mathbf{x} \rangle \leq \beta_i\}$. Since R_I and R_J are n -dimensional, the condition $\text{int } R_I \cap \text{int } R_J = \emptyset$ follows from the above observations and the separation theorem of convex analysis. Similarly we can prove the case of $J \setminus I \neq \emptyset$.

B.2 Proof of Theorem 3.2

We begin with a fundamental tool.

Lemma B.1. *Let $\mathbf{x} \in \mathbb{R}^n$ be given. For each $E \in \mathfrak{X}$, we define j_E and u_E as follows:*

$$j_E = \left(\bigwedge_{\substack{j \in E \\ j \neq e}} x_j - x_e \right)^-, \quad u_E = \left(\bigwedge_{\substack{j \in E \\ j \neq e}} x_j - x_e \right)^+, \quad (\text{B.1})$$

where $e = \max E$. Then for every $F \subset X$, the following relation holds

$$\bigwedge_{j \in F} x_j = x_i - \sum_{\substack{E \in \mathfrak{X} \\ E \preceq F}} u_E,$$

where $i = \min F$.

Proof. By induction on the number of F . Note that the relation $x \wedge y = x - (x - y)^+$ holds for all $x, y \in \mathbb{R}$. In the case of $F = \{i\}$. There is no $E \in \mathfrak{X}$ such that $E \preceq F$. Thus this case is obvious. Suppose the relation holds for $k - 1$. Let $F = \{n_1, n_2, \dots, n_k\}$ be given. Then by the definition of u_F and induction assumption we have

$$\begin{aligned} \bigwedge_{j=1}^k x_{n_j} &= \left(\bigwedge_{j=1}^{k-1} x_{n_j} \right) \wedge x_{n_k} = \left(\bigwedge_{j=1}^{k-1} x_{n_j} \right) - \left(\left(\bigwedge_{j=1}^{k-1} x_{n_j} \right) - x_{n_k} \right)^+ \\ &= x_i - \sum_{\substack{E \in \mathfrak{X} \\ E \preceq F \\ E \neq F}} u_E - u_F = x_i - \sum_{\substack{E \in \mathfrak{X} \\ E \preceq F}} u_E. \end{aligned}$$

□

We are now ready to prove Theorem 3.2. The proof will consist of the following:

- (i) For each $\mathbf{x} \in \mathbb{R}^n$, the pair of vectors $\mathbf{u} = (u_E)_{E \in \mathfrak{X}}$ and $\mathbf{j} = (j_E)_{E \in \mathfrak{X}}$ obtained from the equation (B.1) becomes a solution to the derived LCP from $(C, D, \mathbf{0})$. In addition, the Choquet integral is obtained by substituting \mathbf{u} and \mathbf{x} for $\varphi_\mu(\mathbf{x}) = A\mathbf{x} + B\mathbf{u}$.
- (ii) The coefficient D of $(A, B, \mathbf{0}; C, D, \mathbf{0})$ turns out to be a P-matrix.

By (i), we will see the existence of a solution to the derived LCP from $(C, D, \mathbf{0})$, and obtain the value of the Choquet integral through $\varphi_\mu(\mathbf{x}) = A\mathbf{x} + B\mathbf{u}$. Moreover, (ii) indicates the uniqueness of the solution to this LCP, and hence we can calculate the vectors \mathbf{u} and \mathbf{j} as the solution to it.

Proof of (i): Firstly, we prove the pair \mathbf{u} and \mathbf{j} to be a solution to the derived LCP $(C, D, \mathbf{0})$. By Lemma B.1 and the definition of u_E and j_E , we have

$$\begin{aligned}
j_E &= x_e - \bigwedge_{\substack{j \in E \\ j \neq e}} x_j + u_E \\
&= x_e - x_f + \sum_{\substack{F \in \mathfrak{X} \\ F \succeq E \setminus \{e\}}} u_F + u_E \\
&= x_e - x_f + \sum_{\substack{F \in \mathfrak{X} \\ F \prec E \\ F \neq E}} u_F + u_E \\
&= x_e - x_f + \sum_{\substack{F \in \mathfrak{X} \\ F \prec E}} u_F \\
&= \sum_{j \in X} c_{E,j} x_j + \sum_{F \in \mathfrak{X}} d_{E,F} u_F,
\end{aligned}$$

where $\min E = f$. This indicates that the first part of the equation in the LCP holds. The complementarity condition between \mathbf{u} and \mathbf{j} is directly follows from the definition of u_E and j_E . Therefore, we conclude that the pair \mathbf{u} and \mathbf{j} is a solution to the argued LCP. Secondly, we see the equation $\varphi_\mu(\mathbf{x}) = A\mathbf{x} + B\mathbf{u}$. Since $2^X \setminus \{\emptyset\} = \bigsqcup_{i \in X} \{F \subset X \mid F \succeq \{i\}\}$ holds, where \bigsqcup denotes the direct sum on a family of sets, it follows from Proposition

3.3 and Lemma B.1 that

$$\begin{aligned}
\varphi_\mu(\mathbf{x}) &= \sum_{F \subset \mathfrak{X}} \bigwedge_{j \in F} x_j \mu^m(F) = \sum_{i=1}^n \sum_{F \succeq \{i\}} \bigwedge_{j \in F} x_j \mu^m(F) \\
&= \sum_{i=1}^n \sum_{F \succeq \{i\}} \left(x_i - \sum_{\substack{E \in \mathfrak{X} \\ E \prec F}} u_E \right) \mu^m(F) \\
&= \sum_{i=1}^n \sum_{F \succeq \{i\}} \mu^m(F) x_i - \sum_{i=1}^n \sum_{F \succeq \{i\}} \sum_{\substack{E \in \mathfrak{X} \\ E \prec F}} \mu^m(F) u_E \\
&= \sum_{i=1}^n \sum_{F \succeq \{i\}} \mu^m(F) x_i - \sum_{F \in \mathfrak{X}} \sum_{\substack{E \in \mathfrak{X} \\ E \prec F}} \mu^m(F) u_E \\
&= \sum_{i=1}^n \sum_{F \succeq \{i\}} \mu^m(F) x_i - \sum_{E \in \mathfrak{X}} \sum_{F \succeq E} \mu^m(F) u_E \\
&= \sum_{i=1}^n a_i x_i + \sum_{E \in \mathfrak{X}} b_E u_E.
\end{aligned}$$

□

Proof of (ii): For a coefficient matrix $D = (d_{E,F})_{E,F \in \mathfrak{X}}$, we denote by \mathcal{D} the set of all principal submatrices, i.e., $\mathcal{D} = \{D_{\mathfrak{F}} \mid \mathfrak{F} \subset \mathfrak{X}, \mathfrak{F} \neq \emptyset\}$, where $D_{\mathfrak{F}} = (d_{E,F})_{E,F \in \mathfrak{F}}$. By the definition of P-matrix, it suffices to show that all principal minors of D have positive value, that is, $\det D_{\mathfrak{F}} > 0$ for all $D_{\mathfrak{F}} \in \mathcal{D}$.

In the case of $\mathfrak{F} = \{F\}$ ($F \in \mathfrak{X}$): It is clear, as the relation $D_{\mathfrak{F}} = (d_{F,F}) = (1)$ holds.

In the case of $|\mathfrak{F}| \geq 2$: Let $S(\mathfrak{F})$ be the set of all permutations on \mathfrak{F} , then by definition of the determinant of a square matrix, we have

$$\det D_{\mathfrak{F}} = \sum_{\sigma \in S(\mathfrak{F})} \text{sgn } \sigma \prod_{F \in \mathfrak{F}} d_{F, \sigma(F)}. \quad (\text{B.2})$$

Thus, it suffices to show the following condition instead of $\det D_{\mathfrak{F}} > 0$:

$$(*) \quad \forall \sigma \in S(\mathfrak{F}), \sigma \neq \iota \Rightarrow \exists F \in \mathfrak{F}, d_{F, \sigma(F)} = 0,$$

where ι denotes the identity permutation on \mathfrak{F} . If we done, we can obtain the following

$$\det D_{\mathfrak{F}} = \text{sgn } \iota \prod_{F \in \mathfrak{F}} d_{F,F} = 1.$$

By contradiction. Suppose the negation of (*):

(*)' $\exists \sigma \in S(\mathfrak{F})$, $\sigma \neq \iota$, $\forall F \in \mathfrak{F}$, $d_{F, \sigma(F)} = 1$.

Since $\sigma \neq \iota$, there exists $F \in \mathfrak{F}$ such that $\sigma(F) \neq F$. Moreover, there exists a positive integer $p \geq 2$ such that $\sigma^p(F) = F$, for $|\mathfrak{F}| \geq 2$ and $\sigma \neq \iota$. Then, by the definition of $d_{E, F}$, it holds that

$$F = \sigma^p(F) \preceq \sigma^{p-1}(F) \preceq \dots \preceq \sigma(F) \preceq F,$$

and hence $F = \sigma(F)$ follows from the definition of \preceq . This contradicts to the relation $\sigma(F) \neq F$. Thus the condition (*) holds. \square

B.3 Proof of Theorem 4.2

(i) Suppose that $y = f(\mathbf{x})$ and $y' = f'(\mathbf{x})$ have ULT-representations

$$\begin{aligned} y &= A\mathbf{x} + B\mathbf{u} + g, & y' &= A'\mathbf{x} + B'\mathbf{u}' + g', \\ \mathbf{j} &= C\mathbf{x} + D\mathbf{u} + \mathbf{h}, & \text{and} & \mathbf{j}' = C'\mathbf{x} + D'\mathbf{u}' + \mathbf{h}', \\ \mathbf{u} \geq \mathbf{0}, \mathbf{j} \geq \mathbf{0}, \langle \mathbf{u}, \mathbf{j} \rangle &= 0, & \mathbf{u}' \geq \mathbf{0}, \mathbf{j}' \geq \mathbf{0}, \langle \mathbf{u}', \mathbf{j}' \rangle &= 0, \end{aligned}$$

respectively. Define the new variables

$$\mathbf{u}'' = \begin{pmatrix} \mathbf{u} \\ \mathbf{u}' \\ \tilde{u} \end{pmatrix}, \quad \mathbf{j}'' = \begin{pmatrix} \mathbf{j} \\ \mathbf{j}' \\ \tilde{j} \end{pmatrix},$$

where $\tilde{u} = (y - y')^+$ and $\tilde{j} = (y - y')^- (= \tilde{u} - (y - y'))$. Then, by the relations

$$\begin{aligned} y \vee y' &= y' + (y - y')^+ = y' + \tilde{u}, \\ y \wedge y' &= y - (y - y')^+ = y - \tilde{u}, \end{aligned}$$

we have the following:

$$y \vee y' = A'\mathbf{x} + B'\mathbf{u}' + g' + \tilde{u} = A'\mathbf{x} + \begin{pmatrix} O & B' & 1 \end{pmatrix} \mathbf{u}'' + g', \quad (\text{B.3})$$

$$y \wedge y' = A\mathbf{x} + B\mathbf{u} + g - \tilde{u} = A\mathbf{x} + \begin{pmatrix} B & O & -1 \end{pmatrix} \mathbf{u}'' + g, \quad (\text{B.4})$$

$$\begin{aligned} \mathbf{j}'' &= \begin{pmatrix} C\mathbf{x} + D\mathbf{u} + \mathbf{h} \\ C'\mathbf{x} + D'\mathbf{u}' + \mathbf{h}' \\ (A' - A)\mathbf{x} + B'\mathbf{u}' - B\mathbf{u} + g' - g + \tilde{u} \end{pmatrix}, \\ &= \begin{pmatrix} C \\ C' \\ A' - A \end{pmatrix} \mathbf{x} + \begin{pmatrix} D & O & \mathbf{0} \\ O & D' & \mathbf{0} \\ -B & B' & 1 \end{pmatrix} \mathbf{u}'' + \begin{pmatrix} \mathbf{h} \\ \mathbf{h}' \\ g' - g \end{pmatrix}. \end{aligned} \quad (\text{B.5})$$

Since D and D' are ULT-matrices, so is the coefficient of \mathbf{u}'' in (B.5). Clearly, the variables \mathbf{u}'' and \mathbf{j}'' satisfy the complementarity condition by its definition. Thus the pair of formulas (B.3) and (B.5) [resp. (B.4) and (B.5)] is a ULT-representation of $y \vee y'$ [resp. $y \wedge y'$].

(ii) Suppose $\mathbf{y} = f(\mathbf{x})$ and $\mathbf{y}' = f'(\mathbf{x})$ have ULT-representations:

$$\begin{aligned} \mathbf{y} &= A\mathbf{x} + B\mathbf{u} + \mathbf{g}, & \mathbf{y}' &= A'\mathbf{x} + B'\mathbf{u}' + \mathbf{g}', \\ \mathbf{j} &= C\mathbf{x} + D\mathbf{u} + \mathbf{h}, & \text{and} & \mathbf{j}' &= C'\mathbf{x} + D'\mathbf{u}' + \mathbf{h}', \\ \mathbf{u} \geq \mathbf{0}, \mathbf{j} \geq \mathbf{0}, \langle \mathbf{u}, \mathbf{j} \rangle &= 0, & \mathbf{u}' \geq \mathbf{0}, \mathbf{j}' \geq \mathbf{0}, \langle \mathbf{u}', \mathbf{j}' \rangle &= 0, \end{aligned}$$

respectively. Define new variables

$$\mathbf{y}'' = (f \oplus f')(\mathbf{x}) = \begin{pmatrix} \mathbf{y} \\ \mathbf{y}' \end{pmatrix}, \quad \mathbf{u}'' = \begin{pmatrix} \mathbf{u} \\ \mathbf{u}' \end{pmatrix}, \quad \mathbf{j}'' = \begin{pmatrix} \mathbf{j} \\ \mathbf{j}' \end{pmatrix}.$$

Then we have the following:

$$\mathbf{y}'' = \begin{pmatrix} A\mathbf{x} + B\mathbf{u} + \mathbf{g} \\ A'\mathbf{x} + B'\mathbf{u}' + \mathbf{g}' \end{pmatrix} = \begin{pmatrix} A \\ A' \end{pmatrix} \mathbf{x} + \begin{pmatrix} B & O \\ O & B' \end{pmatrix} \mathbf{u}'' + \begin{pmatrix} \mathbf{g} \\ \mathbf{g}' \end{pmatrix}, \quad (\text{B.6})$$

$$\mathbf{j}'' = \begin{pmatrix} C\mathbf{x} + D\mathbf{u} + \mathbf{h} \\ C'\mathbf{x} + D'\mathbf{u}' + \mathbf{h}' \end{pmatrix} = \begin{pmatrix} C \\ C' \end{pmatrix} \mathbf{x} + \begin{pmatrix} D & O \\ O & D' \end{pmatrix} \mathbf{u}'' + \begin{pmatrix} \mathbf{h} \\ \mathbf{h}' \end{pmatrix}. \quad (\text{B.7})$$

Since D and D' are ULT-matrices, so is the coefficient of \mathbf{u}'' in (B.7). As is the case with (i), \mathbf{u}'' and \mathbf{j}'' satisfy the complementarity condition. Thus the pair of formulas (B.6) and (B.7) is a ULT-representation of \mathbf{y}'' .

(iii) Suppose $\mathbf{y} = f(\mathbf{x})$ and $\mathbf{y}' = f'(\mathbf{y})$ have ULT-representations:

$$\begin{aligned} \mathbf{y} &= A\mathbf{x} + B\mathbf{u} + \mathbf{g}, & \mathbf{y}' &= A'\mathbf{y} + B'\mathbf{u}' + \mathbf{g}', \\ \mathbf{j} &= C\mathbf{x} + D\mathbf{u} + \mathbf{h}, & \text{and} & \mathbf{j}' &= C'\mathbf{y} + D'\mathbf{u}' + \mathbf{h}', \\ \mathbf{u} \geq \mathbf{0}, \mathbf{j} \geq \mathbf{0}, \langle \mathbf{u}, \mathbf{j} \rangle &= 0, & \mathbf{u}' \geq \mathbf{0}, \mathbf{j}' \geq \mathbf{0}, \langle \mathbf{u}', \mathbf{j}' \rangle &= 0, \end{aligned}$$

respectively. Define the new variables

$$\mathbf{y}'' = (f' \circ f)(\mathbf{x}), \quad \mathbf{u}'' = \begin{pmatrix} \mathbf{u} \\ \mathbf{u}' \end{pmatrix}, \quad \mathbf{j}'' = \begin{pmatrix} \mathbf{j} \\ \mathbf{j}' \end{pmatrix}.$$

Then we have the following:

$$\begin{aligned}
\mathbf{y}'' &= A'(A\mathbf{x} + B\mathbf{u} + \mathbf{g}) + B'\mathbf{u}' + \mathbf{g}', \\
&= A'A\mathbf{x} + A'B\mathbf{u} + A'\mathbf{g} + B'\mathbf{u}' + \mathbf{g}', \\
&= A'A\mathbf{x} + (A'B \quad B') \mathbf{u}'' + A'\mathbf{g} + \mathbf{g}',
\end{aligned} \tag{B.8}$$

$$\begin{aligned}
\mathbf{j}'' &= \begin{pmatrix} C\mathbf{x} + D\mathbf{u} + \mathbf{h} \\ C'(A\mathbf{x} + B\mathbf{u} + \mathbf{g}) + D'\mathbf{u}' + \mathbf{h}' \end{pmatrix}, \\
&= \begin{pmatrix} C \\ C'A \end{pmatrix} \mathbf{x} + \begin{pmatrix} D & O \\ C'B & D' \end{pmatrix} \mathbf{u}'' + \begin{pmatrix} \mathbf{h} \\ C'\mathbf{g} + \mathbf{h}' \end{pmatrix}.
\end{aligned} \tag{B.9}$$

Since D and D' are ULT-matrices, so is the coefficient of \mathbf{u}'' in (B.9). Clearly, \mathbf{u}'' and \mathbf{j}'' satisfy the complementarity condition. Thus the pair of formulas (B.8) and (B.9) is a ULT-representation of \mathbf{y}'' .

(iv) Suppose $\mathbf{y} = f(\mathbf{x})$ and $\mathbf{y}' = f'(\mathbf{x})$ have ULT-representations:

$$\begin{aligned}
\mathbf{y} &= A\mathbf{x} + B\mathbf{u} + \mathbf{g}, & \mathbf{y}' &= A'\mathbf{x} + B'\mathbf{u}' + \mathbf{g}', \\
\mathbf{j} &= C\mathbf{x} + D\mathbf{u} + \mathbf{h}, & \text{and} & \mathbf{j}' = C'\mathbf{x} + D'\mathbf{u}' + \mathbf{h}', \\
\mathbf{u} \geq \mathbf{0}, \mathbf{j} \geq \mathbf{0}, \langle \mathbf{u}, \mathbf{j} \rangle &= 0, & \mathbf{u}' \geq \mathbf{0}, \mathbf{j}' \geq \mathbf{0}, \langle \mathbf{u}', \mathbf{j}' \rangle &= 0,
\end{aligned}$$

respectively. Thus, for $\lambda, \nu \in \mathbb{R}$, if we put $\mathbf{y}'' = (\lambda f + \nu f')(\mathbf{x})$, and define new variables

$$\mathbf{u}'' = \begin{pmatrix} \mathbf{u} \\ \mathbf{u}' \end{pmatrix}, \quad \mathbf{j}'' = \begin{pmatrix} \mathbf{j} \\ \mathbf{j}' \end{pmatrix},$$

then we have the following:

$$\begin{aligned}
\mathbf{y}'' &= \lambda(A\mathbf{x} + B\mathbf{u} + \mathbf{g}) + \nu(A'\mathbf{x} + B'\mathbf{u}' + \mathbf{g}'), \\
&= (\lambda A + \nu A')\mathbf{x} + (\lambda B \quad \nu B') \mathbf{u}'' + \lambda\mathbf{g} + \nu\mathbf{g}'
\end{aligned} \tag{B.10}$$

$$\begin{aligned}
\mathbf{j}'' &= \begin{pmatrix} C\mathbf{x} + D\mathbf{u} + \mathbf{h} \\ C'\mathbf{x} + D'\mathbf{u}' + \mathbf{h}' \end{pmatrix} \\
&= \begin{pmatrix} C \\ C' \end{pmatrix} \mathbf{x} + \begin{pmatrix} D & O \\ O & D' \end{pmatrix} \mathbf{u}'' + \begin{pmatrix} \mathbf{h} \\ \mathbf{h}' \end{pmatrix}.
\end{aligned} \tag{B.11}$$

Similarly, we see that the pair of formulas (B.10) and (B.11) is a ULT-representation of \mathbf{y}'' .

B.4 Proof of Theorem 5.2

Proof of (i) Let F be defined as $F = P(\alpha) \cap P(\alpha')$. By Theorem A.3 it suffices to show that F is an extreme subset of $P(\alpha)$ and $P(\alpha')$. Let $\mathbf{x}, \mathbf{x}' \in P(\alpha)$ be given. Suppose

$\lambda \mathbf{x} + (1 - \lambda) \mathbf{x}' \in F$ for some $\lambda \in (0, 1)$. By definition of F and Lemma A.2, it holds that $(C^{-1}(\alpha) \mathbf{q}(\lambda \mathbf{x} + (1 - \lambda) \mathbf{x}'))_{\alpha \Delta \alpha'} = \mathbf{0}$. The affine linearity of the mapping $\mathbf{q} : \mathbb{R}^n \rightarrow \mathbb{R}^k$ leads to the following:

$$\lambda(C^{-1}(\alpha) \mathbf{q}(\mathbf{x}))_{\alpha \Delta \alpha'} + (1 - \lambda)(C^{-1}(\alpha) \mathbf{q}(\mathbf{x}'))_{\alpha \Delta \alpha'} = \mathbf{0}.$$

By definition of $P(\alpha)$, $\boldsymbol{\mu} \triangleq C^{-1}(\alpha) \mathbf{q}(\mathbf{x}) \geq \mathbf{0}$ and $\boldsymbol{\nu} \triangleq C^{-1}(\alpha) \mathbf{q}(\mathbf{x}') \geq \mathbf{0}$ hold. Thus, it follows from $\lambda \in (0, 1)$ that $\boldsymbol{\mu}_{\alpha \Delta \alpha'} = \boldsymbol{\nu}_{\alpha \Delta \alpha'} = \mathbf{0}$. Therefore, by Lemma A.1, we obtain $\mathbf{q}(\mathbf{x}), \mathbf{q}(\mathbf{x}') \in \text{pos } C(\alpha)_{\frac{\alpha \Delta \alpha'}{\alpha \Delta \alpha'}} \subset \text{pos } C(\alpha')$. This means that $\mathbf{x}, \mathbf{x}' \in P(\alpha')$, and hence that $\mathbf{x}, \mathbf{x}' \in F$. So we conclude that F is an extreme subset of $P(\alpha)$. Similarly we can verify that F is an extreme subset of $P(\alpha')$. \square

Proof of (ii) By contradiction. Let F be defined as $F = P(\alpha) \cap P(\alpha')$ (this is a common face of $P(\alpha)$ and $P(\alpha')$ by (i)). Suppose $\text{int } P(\alpha) \cap \text{int } P(\alpha') \neq \emptyset$. Since $\text{int } P(\alpha) \cap \text{int } P(\alpha') \subset \text{int } (P(\alpha) \cap P(\alpha')) = \text{int } F$ holds, it follows that F contains an interior point of $P(\alpha)$ and an interior point of $P(\alpha')$. By Theorem A.2, this implies that F is not proper in both $P(\alpha)$ and $P(\alpha')$. Thus we have $P(\alpha) = F = P(\alpha')$. This contradicts to $P(\alpha) \neq P(\alpha')$. \square

B.5 Proof of Theorem 5.3

Let $\mathbf{y} \in \mathbb{R}^n$ be given. By Lemma A.4, there exists a sequence $\{\mathbf{e}_l\}_{l=1}^{\infty}$ satisfying the conditions (i) and (ii) in Lemma A.4. For \mathbf{e}_l , we define the vector as $\mathbf{y}_l = \mathbf{y} + \mathbf{e}_l$ ($l \geq 1$). Then the sequence $\{\mathbf{y}_l\}_{l=1}^{\infty}$ converges to \mathbf{y} as $l \rightarrow \infty$. Since the family \mathcal{R} is finite, there exists a region $R \in \mathcal{R}$ containing an infinite subsequence $\{\mathbf{y}_l\}_{l=1}^{\infty}$ of $\{\mathbf{y}_l\}_{l=1}^{\infty}$. Clearly, \mathbf{y}_l converges to \mathbf{y} . Note that the region R is closed, this implies $\mathbf{y} \in R$. Moreover, by (ii), $\{\mathbf{y}_l\}_{l=1}^{\infty}$ contains n vectors that are linearly independent, thus, so does R . Therefore R is full dimensional, that is, $\dim(R) = n$. \square

B.6 Proof of Theorem 5.4

Let $\alpha \subset [k]$ and $\mathbf{x} \in P(\alpha)$ be given. Define the vector as $\boldsymbol{\lambda} = C^{-1}(\alpha) \mathbf{q}(\mathbf{x})$. Moreover, for $\boldsymbol{\lambda}$, we define two vectors $\boldsymbol{\mu}$ and $\boldsymbol{\nu}$ as follows:

$$\mu_i = \begin{cases} \lambda_i & i \in \alpha, \\ 0 & i \notin \alpha, \end{cases} \quad \nu_i = \begin{cases} 0 & i \in \alpha, \\ \lambda_i & i \notin \alpha. \end{cases}$$

Then, by the definition of λ , we can easily verify that the pair of vectors $(\boldsymbol{\mu}, \boldsymbol{\nu})$ is a solution to the LCP $(D, \mathbf{q}(\mathbf{x}))$, that is, the following holds:

$$\boldsymbol{\nu} = D\boldsymbol{\mu} + \mathbf{q}(\mathbf{x}), \quad \boldsymbol{\mu}, \boldsymbol{\nu} \geq \mathbf{0}, \quad \langle \boldsymbol{\mu}, \boldsymbol{\nu} \rangle = 0.$$

Since $\mathbf{u}(\mathbf{x})$ is also a solution to it and D is a P-matrix, we have $\mathbf{u}(\mathbf{x}) = \boldsymbol{\mu}$. Therefore, the equations $\mathbf{u}_\alpha(\mathbf{x}) = (C^{-1}(\alpha)\mathbf{q}(\mathbf{x}))_\alpha$ and $\mathbf{u}_{\bar{\alpha}}(\mathbf{x}) = \mathbf{0}$ are followed by the definition of λ and $\boldsymbol{\mu}$. \square

Appendix C

High-level canonical form of Choquet integral

In this appendix, we will discuss the relation between the generalization of Chua canonical form and the Choquet integral. The following properties (i) – (iii) can be easily seen from the definition of high-level canonical form by induction. Note that the proof of (iii) uses the following well-known formulae:

$$x \wedge y = \frac{1}{2}(x + y - |x - y|), \quad x \vee y = \frac{1}{2}(x + y + |x - y|).$$

Proposition C.1. (i) If $f_1 : \mathbb{R}^n \rightarrow \mathbb{R}^{m_1}$ and $f_2 : \mathbb{R}^n \rightarrow \mathbb{R}^{m_2}$ are K_1 th- and K_2 th-level canonical, respectively, then the product $f_1 \times f_2 : \mathbb{R}^n \rightarrow \mathbb{R}^{m_1+m_2}$ is $\max\{K_1, K_2\}$ th-level canonical.

(ii) If $f_1 : \mathbb{R}^n \rightarrow \mathbb{R}^m$, $f_2 : \mathbb{R}^n \rightarrow \mathbb{R}^m$ are K_1 th- and K_2 th-level canonical, respectively, then their linear combination $f = \lambda f_1 + \nu f_2 : \mathbb{R}^n \rightarrow \mathbb{R}^m$, where $\lambda, \nu \in \mathbb{R}$, is $\max\{K_1, K_2\}$ th-level canonical.

(iii) If $f_1 : \mathbb{R}^n \rightarrow \mathbb{R}$, $f_2 : \mathbb{R}^n \rightarrow \mathbb{R}$ are K_1 th- and K_2 th-level canonical, respectively, then $f_1 \wedge f_2 : \mathbb{R}^n \rightarrow \mathbb{R}$ and $f_1 \vee f_2 : \mathbb{R}^n \rightarrow \mathbb{R}$ are $(\max\{K_1, K_2\} + 1)$ th-level canonical.

The next theorem yields the relation between the order of additivity of fuzzy measure and the canonicity level of Choquet integral.

Theorem C.1. The Choquet integral φ_μ with respect to a k -additive fuzzy measure μ is a $\lceil \log_2 k \rceil$ th-level canonical piecewise linear function.

Proof. Let $A (\neq \emptyset) \subset X$ be given. Then, by induction on $|A|$ and Proposition C.1.(iii), we can show that any function of the form $f_A(\mathbf{x}) = \bigwedge_{i \in A} p_i(\mathbf{x})$, where p_i is the projection

onto the i -th coordinate, that is, $p_i(\mathbf{x}) = p_i(x_1, x_2, \dots, x_n) = x_i$, is a $\lceil \log_2 |A| \rceil$ -th-level canonical piecewise linear function. By Proposition 3.3, the Choquet integral $\varphi_\mu(\mathbf{x})$ with respect to a k -additive fuzzy measure μ is expressed as follows:

$$\varphi_\mu(\mathbf{x}) = \sum_{\substack{A \subset X \\ 0 < |A| \leq k}} f_A(\mathbf{x}) \mu^m(A).$$

Thus, by Proposition C.1 (ii), $\varphi_\mu(\mathbf{x})$ is a $\lceil \log_2 k \rceil$ -th-level canonical piecewise linear function. □

The proof is constructive, and thus yields a construction method of an absolute valued-sign representation for a given Choquet integral. On the other hand, Theorem C.1 claims that there exists no one-to-one relation between the order of additivity of fuzzy measure and the canonicity level. For example, the Choquet integral with respect to three- and four-additive fuzzy measures are both second-level canonical piecewise linear functions (in addition, by Theorem 3.1 neither is first-level canonical). In generally, for $2^{K-1} < k < k' \leq 2^K$, the Choquet integral with respect to k - and k' -additive fuzzy measures are both K -th-level canonical. This means that the absolute-valued sign representation causes the lack of information on the order of additivity of fuzzy measure.

Appendix D

Construction of max-min polynomial

D.1 Construction procedure

Let $f : \mathbb{R}^n \rightarrow \mathbb{R}$ be a piecewise linear function, and let $\{g_1, g_2, \dots, g_l\}$ be all its linear segments (i.e., each g_i can be expressed as $g_i(\mathbf{x}) = \mathbf{a}_i^T \mathbf{x} + b_i$ for some non-zero vector $\mathbf{a}_i \in \mathbb{R}^n$ and scalar $b_i \in \mathbb{R}$, and they satisfy that $i \neq j$ implies $(\mathbf{a}_i; b_i) \neq (\mathbf{a}_j; b_j)$).

Step 1 Let \mathcal{H} be the set of all hyperplane that are nonempty solution sets of the equations in the form $g_i(\mathbf{x}) = g_j(\mathbf{x})$ for $i < j$: Note that \mathcal{H} is a linear partition of \mathbb{R}^n satisfying the condition (pwl) in Definition 2.5 for f .

Step 2 Let \mathcal{T} be the family of regions generated by \mathcal{H} .

Step 3 Consider the pairs (g_i, g_j) for $i < j$ that satisfy the following conditions: There are adjacent regions $P, Q \in \mathcal{T}$ satisfying the following:

- (i) $g_i(\mathbf{x}) = f(\mathbf{x})$ on P and $g_j(\mathbf{x}) = f(\mathbf{x})$ on Q ,
- (ii) $f(\mathbf{x}) = g_i(\mathbf{x}) \vee g_j(\mathbf{x})$ on $P \cup Q$.

Step 4 Let \mathcal{H}' be the set of all hyperplanes defined by the above pares, and let \mathcal{T}' be the family of regions generated by \mathcal{H}' .

Step 5 For $P \in \mathcal{T}'$, define the index set S_P as follows:

$$S_P \triangleq \{i \in [l] \mid g_i(\mathbf{x}) \geq f(\mathbf{x}), \forall \mathbf{x} \in P\}.$$

Step 6 Construct the formular as $f(\mathbf{x}) = \bigvee_{P \in \mathcal{T}'} \bigwedge_{i \in S_P} g_i(\mathbf{x})$.

Remark D.1. In [28], Ovchinnikov has asserted that S_P 's obtained in **Step 5** are incomparable with respect to the set inclusion. However, this is not true. A counter example will be given in Example D.1.

D.2 Examples

Example D.1. Consider the piecewise linear function $f : \mathbb{R}^2 \rightarrow \mathbb{R}$ defined as follows:

$$f(x, y) = \begin{cases} g_1(x, y) & P_1 = \{(x, y) \mid x, y \geq 0\}, \\ g_2(x, y) & P_2 = \{(x, y) \mid y \leq 0, y \leq x\}, \\ g_3(x, y) & P_3 = \{(x, y) \mid x \leq y, y \leq -x\}, \\ g_4(x, y) & P_4 = \{(x, y) \mid -x \leq y, x \leq 0\}, \end{cases}$$

where $g_1(x, y) = x - y$, $g_2(x, y) = x$, $g_3(x, y) = y$, and $g_4(x, y) = -2x - y$. Then the max-min polynomial of f is obtained by the following:

$$f = (g_1 \wedge g_2) \vee (g_3 \wedge g_4) \vee (g_1 \wedge g_3 \wedge g_4) \vee (g_2 \wedge g_3 \wedge g_4). \quad (\text{D.1})$$

However the above representation can be reduced to the following:

$$f = (g_1 \wedge g_2) \vee (g_3 \wedge g_4), \quad (\text{D.2})$$

where the next relation is used:

$$S \subset T \Rightarrow \bigwedge_{i \in S} g_i(x, y) \geq \bigwedge_{i \in T} g_i(x, y), \quad \text{for all } (x, y) \in \mathbb{R}^2.$$

Proof. By definition of \mathcal{H} , it consists of the following six hyperplanes:

$$\begin{aligned} H_1 &= \{(x, y) \in \mathbb{R}^2 \mid y = 0\}, \quad H_2 = \{(x, y) \in \mathbb{R}^2 \mid x + y = 0\}, \\ H_3 &= \{(x, y) \in \mathbb{R}^2 \mid x - 2y = 0\}, \quad H_4 = \{(x, y) \in \mathbb{R}^2 \mid x = 0\}, \\ H_5 &= \{(x, y) \in \mathbb{R}^2 \mid x - y = 0\}, \quad H_6 = \{(x, y) \in \mathbb{R}^2 \mid 3x + y = 0\}. \end{aligned}$$

The hyperplanes that satisfy the condition (i) and (ii) of **step3** are H_4 and H_5 . Thus $\mathcal{H}' = \{H_4, H_5\}$, and hence \mathcal{T}' consists of the following four regions:

$$\begin{aligned} P_1 &= \{(x, y) \in \mathbb{R}^2 \mid x \geq 0, x \geq y\}, \quad P_2 = \{(x, y) \in \mathbb{R}^2 \mid x \geq 0, x \leq y\}, \\ P_3 &= \{(x, y) \in \mathbb{R}^2 \mid x \leq 0, x \geq y\}, \quad P_4 = \{(x, y) \in \mathbb{R}^2 \mid x \leq 0, x \leq y\}. \end{aligned}$$

Then the index sets S_{P_i} defined in **Step5** are obtained as follows:

$$S_{P_1} = \{3, 4\}, \quad S_{P_2} = \{1, 3, 4\}, \quad S_{P_3} = \{2, 3, 4\}, \quad S_{P_4} = \{1, 2\}.$$

Hence the max-min polynomial of f is obtained by the following:

$$f = (g_1 \wedge g_2) \vee (g_3 \wedge g_4) \vee (g_1 \wedge g_3 \wedge g_4) \vee (g_2 \wedge g_3 \wedge g_4).$$

However, the following inequalities hold

$$g_3 \wedge g_4 \geq g_1 \wedge g_3 \wedge g_4, \quad g_3 \wedge g_4 \geq g_2 \wedge g_3 \wedge g_4,$$

for $S_{P_1} \subset S_{P_2}$ and $S_{P_1} \subset S_{P_3}$ are satisfied, the above max-min polynomial reduces to

$$f = (g_1 \wedge g_2) \vee (g_3 \wedge g_4).$$

□

Example D.2. Consider the piecewise linear function $f : \mathbb{R} \rightarrow \mathbb{R}$ defined as follows:

$$f(x) = \begin{cases} g_1(x) & x \leq 2, 5 \leq x \\ g_2(x) & 2 \leq x \leq 3 \\ g_3(x) & 3 \leq x \leq 4 \\ g_4(x) & 4 \leq x \leq 5, \end{cases}$$

where $g_1(x) = x$, $g_2(x) = -x + 4$, $g_3(x) = 4x - 11$, and $g_4(x) = 5$. As is the case with Example D.1, the max-min polynomial of f is obtained as follow:

$$f = (g_1 \wedge g_2 \wedge g_4) \vee (g_3 \wedge g_4) \vee (g_1 \wedge g_3) \tag{D.3}$$

But the above formula can be reduced to the following:

$$f = (g_1 \wedge g_2) \vee (g_3 \wedge g_4) \vee (g_1 \wedge g_3) \tag{D.4}$$

Proof. By definition of \mathcal{H} , it consists of the following six hyperplanes:

$$\begin{aligned} H_1 &= \{x \in \mathbb{R} \mid x = 2\}, \quad H_2 = \{x \in \mathbb{R} \mid x = \frac{3}{11}\}, \quad H_3 = \{x \in \mathbb{R} \mid x = 5\}, \\ H_4 &= \{x \in \mathbb{R} \mid x = 3\}, \quad H_5 = \{x \in \mathbb{R} \mid x = -1\}, \quad H_6 = \{x \in \mathbb{R} \mid x = 4\}. \end{aligned}$$

The hyperplanes that satisfy the condition (i) and (ii) of **step3** are H_4 and H_6 . Thus $\mathcal{H}' = \{H_4, H_6\}$, and hence \mathcal{T}' consists of the following four regions:

$$P_1 = \{x \in \mathbb{R} \mid x \leq 3\}, \quad P_2 = \{x \in \mathbb{R} \mid 3 \leq x \leq 5\}, \quad P_3 = \{x \in \mathbb{R} \mid 5 \leq x\}.$$

Then the index sets S_{P_i} defined in **Step5** are obtained as follows:

$$S_{P_1} = \{1, 2, 4\}, \quad S_{P_2} = \{1, 3, 4\}, \quad S_{P_3} = \{1, 3\}.$$

Hence the max-min polynomial of f is obtained by the following:

$$f = (g_1 \wedge g_2 \wedge g_4) \vee (g_3 \wedge g_4) \vee (g_1 \wedge g_3)$$

However, since $g_1 \wedge g_2 < 5 = g_4$ holds on \mathbb{R} , we have the following:

$$g_1 \wedge g_2 \wedge g_4 = g_1 \wedge g_2.$$

Therefore, the above max-min polynomial reduces to

$$f = (g_1 \wedge g_2) \vee (g_3 \wedge g_4) \vee (g_1 \wedge g_3).$$

□