

論文 / 著書情報
Article / Book Information

題目(和文)	高効率・広バンドギャップAg(In,Ga)Se ₂ 太陽電池の研究
Title(English)	Study of high efficiency wide-bandgap Ag(In,Ga)Se ₂ solar cells
著者(和文)	梅原猛
Author(English)	Takeshi Umehara
出典(和文)	学位:博士(工学), 学位授与機関:東京工業大学, 報告番号:甲第10640号, 授与年月日:2017年9月20日, 学位の種別:課程博士, 審査員:山田 明,中川 茂樹,宮島 晋介,間中 孝彰,PHAM NAM HAI,峯元 高志
Citation(English)	Degree:Doctor (Engineering), Conferring organization: Tokyo Institute of Technology, Report number:甲第10640号, Conferred date:2017/9/20, Degree Type:Course doctor, Examiner:,,,,,
学位種別(和文)	博士論文
Category(English)	Doctoral Thesis
種別(和文)	要約
Type(English)	Outline

DOCTORAL THESIS

**Study of high efficiency wide-bandgap
Ag(In,Ga)Se₂ solar cells**

July, 2017

Directed by Professor Akira Yamada

Presented by Takeshi Umehara

Department of Physical Electronics

Tokyo Institute of Technology

Outline Study of high efficiency wide-bandgap Ag(In,Ga)Se₂ solar cells

Introduction

To achieve conversion efficiencies of over 35% using solar cells, the fabrication of tandem structures is required. In a theoretical calculation on a two-junction solar cell structure, when Cu(In,Ga)Se₂ (CIGS) or Si solar cells with a bandgap of approximately 1.15 eV are used as bottom cells, the top cell bandgap should be approximately 1.75 eV to achieve an efficiency of over 35%.¹⁾ Ag(In,Ga)Se₂ (AIGS) is one of the promising candidates for the top-cell absorber in the tandem structure since its bandgap can be tuned from 1.24 (AgInSe₂) to 1.83 eV (AgGaSe₂) by varying the Ga/(In+Ga) ratio.^{2,3)} However, the conversion efficiency of AIGS solar cells is still lower than that required for the top cell. In this thesis, two efficiency-limiting factors of AIGS solar cells were investigated: the roll-over-shaped current density-voltage (*J-V*) characteristic and the mismatch of the conduction band offset at the CdS/AIGS interface.

Prevention of the roll-over-shaped *J-V* characteristic

One of the causes of the low performance in AIGS solar cells has been considered to be the roll-over shape that appears in the *J-V* curve, as shown in Fig. 1. In general, a roll-over-shaped *J-V* characteristic is modeled as a leaky inverted diode in series with the main junction photodiode.⁴⁾ The leaky inverted diode affects the *J-V* curve of the main photodiode and degrades V_{OC} and particularly FF . Therefore, the origin of the roll-over-shaped *J-V* characteristics was investigated by experimental measurements and device simulation. A measurement of the electrical properties of AIGS layers was first performed because there have been no reports on the measured electrical properties. The electrical properties of the AIGS layer were successfully evaluated by a new technique consisting of AC Hall measurement and a peel-off process to separate the

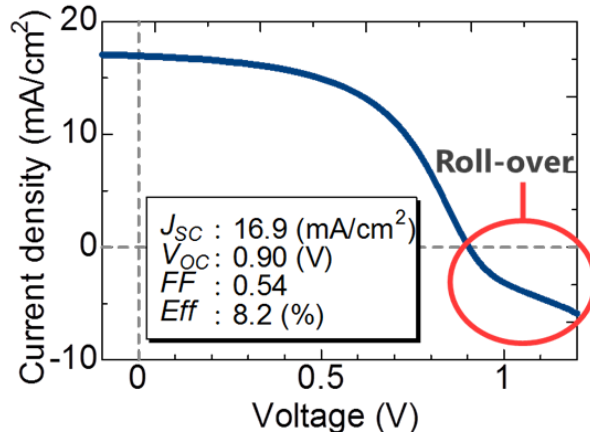

Fig. 1 Typical illuminated J - V curve of an AIGS solar cell.

Here, J_{SC} is short-circuit current density, V_{OC} is open-circuit voltage, FF is fill factor, and Eff is conversion efficiency.

AIGS layer from the Mo-coated soda-lime glass substrate, and a hole concentration of $2.2 \times 10^{12} \text{ cm}^{-3}$ and the mobility of $0.35 \text{ cm}^2/(\text{V}\cdot\text{s})$ was measured.^{5,6)} The theoretical simulation based on the measured electrical properties revealed that the roll-over shape is due to the very low hole concentration. Under an applied forward bias, the band bending near the back contact of the AIGS layer forms an intrinsic semiconductor owing to the injected electrons, leading to the formation of an inverted diode.⁶⁾

One obvious means of avoiding a roll-over-shaped J - V curve is to increase the hole concentration in the AIGS layer. Figure 2 shows the calculated J - V curves when the hole concentration of the AIGS layer was increased from 2.0×10^{12} to $3.0 \times 10^{15} \text{ cm}^{-3}$ by fixing the deep donor-like defect concentration at $3.28 \times 10^{14} \text{ cm}^{-3}$ and increasing the shallow acceptor concentration from 3.30×10^{14} to $3.30 \times 10^{15} \text{ cm}^{-3}$. As a result, the roll-over shape disappeared from the J - V curve, and Eff was significantly improved from 8.4 to 13.1%. Moreover, the hole concentration of the AIGS layer was

Outline Study of high efficiency wide-bandgap Ag(In,Ga)Se₂ solar cells

increased by NaF postdeposition treatment and an improvement of V_{OC} and FF was confirmed. V_{OC} , FF , and Eff were improved from 0.90 V, 0.49, and 7.1% to 0.98 V, 0.55, and 8.5%, respectively.⁶⁾

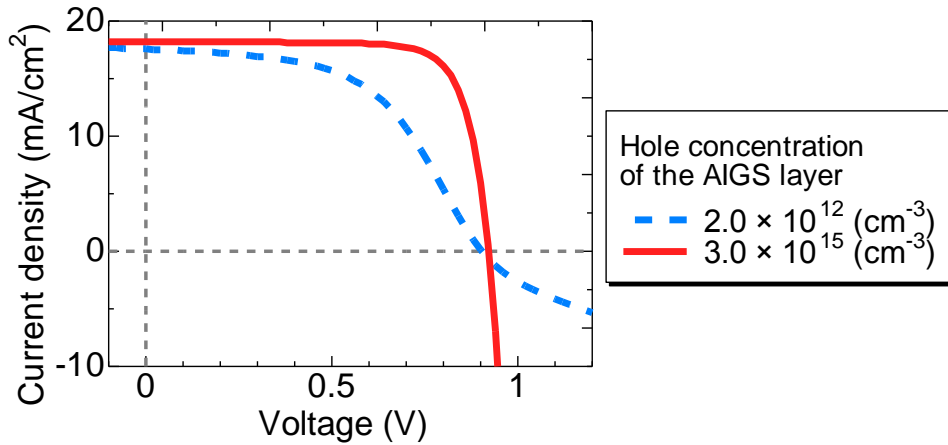

Fig.2 Calculated J - V curves when the hole concentration of the AIGS layer was increased from 2.0×10^{12} to $3.0 \times 10^{15} \text{ cm}^{-3}$.

Mismatch of the conduction band offset at the CdS/AIGS interface

To further improve the conversion efficiency of AIGS solar cells, it is necessary to reduce the mismatch due to the conduction band offset (CBO) at the buffer layer/AIGS interface.⁷⁾ Although CdS is currently used as the main buffer layer in AIGS solar cells, the CBO at a CdS/AIGS interface was measured by in situ photoemission spectroscopy and inverse photoemission spectroscopy, and its value was approximately -0.4 eV ,⁸⁾ suggesting the presence of a strong cliff-type alignment at the interface, as shown in Fig. 3. The recombination at the CdS/AIGS interface was reduced by introducing a ZnS(O,OH) buffer layer instead of a CdS buffer layer. As a result, V_{OC} and J_{SC} were improved, although FF decreased markedly. The theoretical simulation indicates that the decrease in FF is caused by a large CBO of 1.0 eV at the

Outline Study of high efficiency wide-bandgap Ag(In,Ga)Se₂ solar cells

ZnS(O,OH)/ZnO interface, which hinders the flow of electrons under an applied forward bias. Therefore, in this thesis, the introduction of a CdS/ZnS(O,OH) hybrid buffer layer is proposed, which can lower both CBOs.⁹⁾ Figure 4 shows the band alignment of ZnO/CdS/ZnS(O,OH)/AIGS structure without bias voltage. As a result, the decrease in FF was suppressed compared with that for the ZnS(O,OH) single buffer layer owing to the reduced value of the CBO at the buffer/ZnO interface, and finally the solar cell performance with a bandgap of approximately 1.75 eV was $J_{SC} = 16.8$ mA/cm², $V_{OC} = 0.98$ V, $FF = 0.59$, and $Eff = 9.7\%$.

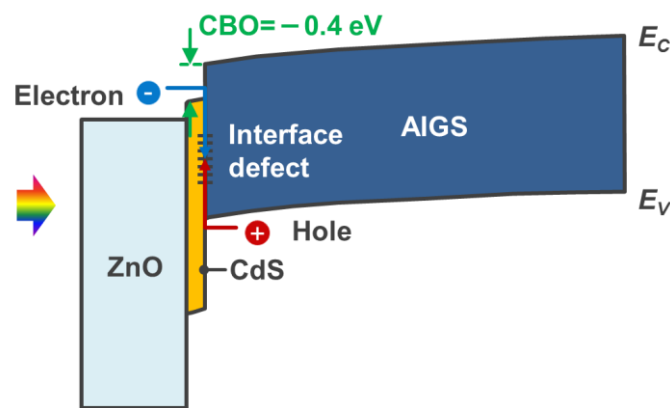

Fig. 3 Band alignment of ZnO/CdS/AIGS structure without bias voltage.

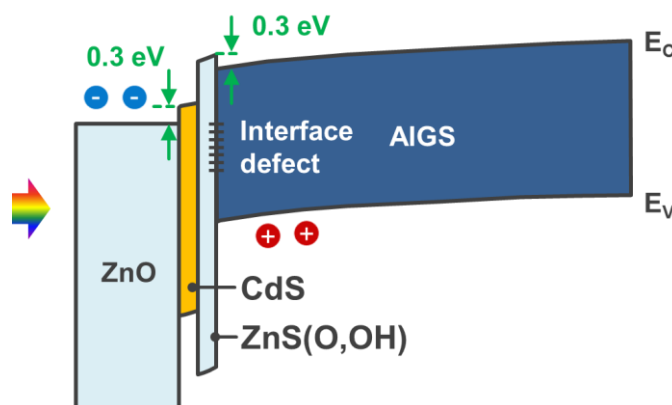

Fig. 4 Band alignment of ZnO/CdS/ZnS(O,OH)/AIGS structure without bias voltage.

Outline Study of high efficiency wide-bandgap Ag(In,Ga)Se₂ solar cells

References

- 1) V. Shah, M. Vaněček, J. Meier, F. Meillaud, J. Guillet, D. Fischer, C. Droz, X. Niquille, S. Fay, E. Vallat-Sauvain, V. Terrazzoni-Daudrix, and J. Bailat, J. Non-Cryst. Solids **338–340**, 639 (2004).
- 2) J. L. Shay, B. Tell, H. M. Kasper, and L. M. Schiavone, Phys. Rev. B **7**, 4485 (1973).
- 3) B. Tell and H. M. Kasper, Phys. Rev. B **4**, 4455 (1971).
- 4) A. Niemegeers and M. Burgelman, J. Appl. Phys. **81**, 2881 (1997).
- 5) T. Umehara, S. Iinuma, A. Sadono, Y. Kurokawa, and A. Yamada, Jpn. J. Appl. Phys. **54**, 018001 (2015). DOI: 10.7567/JJAP.54.018001.
- 6) T. Umehara, K. Nakada, and Akira Yamada, Jpn. J. Appl. Phys. **56**, 012302 (2017). DOI: 10.7567/JJAP.56.012302.
- 7) T. Minemoto, T. Matsui, H. Takakura, Y. Hamakawa, T. Negami, Y. Hashimoto, T. Uenoyama, and M. Kitagawa, Sol. Energy Mater. Sol. Cells **67**, 83 (2001).
- 8) K. Isowaki, T. Fukuyama, S. Kawamura, K. Kawasaki, T. Umehara, A. Yamada, N. Terada, Proc. European Materials Research Society 2016 Spring Meet., 2016, V.P1.26.
- 9) T. Umehara, F. A. M. Zulkifly, K. Nakada, and A. Yamada, Jpn. J. Appl. Phys. **56**, 08MC09 (2017). DOI: 10.7567/JJAP.56.08MC09.