

論文 / 著書情報
Article / Book Information

Title	Detection of P300 brain waves using a Magneto-Impedance sensor
Authors	K. Wang, S. Tajima, Y. Asano, Y.Okuda, N. Hamada, C. Cai, T. Uchiyama
Citation	Proceedings of the 8th International Conference on Sensing Technology, , , pp. 547-550
Pub. date	2014, 9

Detection of P300 brain waves using a Magneto-Impedance sensor

K. Wang¹, S. Tajima¹, Y. Asano¹, Y. Okuda¹, N. Hamada², C. Cai², and T. Uchiyama¹

¹Graduate School of Engineering, Nagoya University, Nagoya, Japan

²Aichi Steel Corporation, Tokai, Japan
o_kabou @ echo.nuee.nagoya-u.ac.jp

Abstract— We have previously reported a study on brain activity detection in occipital region using a picotesla-scale Magneto-Impedance (MI) sensor. Based on past studies, the target of the present study was to review the performance of MI sensor on parietal region brain activity detection. Human brain magnetic field is extremely weak, in order to detect the faint magnetic field, we constructed an MI measurement system that can cancel out the background noise (e.g., geomagnetic field) instead of using a magnetic shielding. In this study, we recorded P300 brain waves of subjects, compared our results with our past studies and other EEG and MEG data reported previously. The results confirmed the reliability of our data and indicated that the MI sensor can be applied on brain activity detection.

Keywords-Biomagnetic field measurement; Magneto-Impedance sensor; MEG; P300 brain waves

I. INTRODUCTION

Detecting and analysing biosignals of the human brain could be beneficial for us to figure out the brain construction and operational function. The application of brain signals detection also was developed in various fields. In medicine area, it could be implemented in such as brain injury inspection, diagnosis of neocortical epilepsy, telemedicine or cognitive functions research. And with advances in sensing technology, neuroprosthetics applications based on brain computer interfacing (BCI) could be improved and used to restore damaged hearing, sight or movement.

Event-related potentials (ERP) is one of the important biosignals of the brain which has a wide application in examining brain activity and cognitive functions[1]. ERPs are comprised of a series of positive and negative voltage deflections which could be distinguished by their relative latency and polarity.

The P300 (or P3) is one of the ERP components which normally elicited in the process of making decisions. It surfaces as a positive deflection with a latency of roughly 250 to 500 ms[2]. In application level, the P300 brain waves have been used in various fields such as lie detection, BCI and cognitive impairment examination. However, the P300 is not a unitary phenomenon, research had shown that it contains two distinguishable subcomponents, the P3a (or novelty P3) and the P3b (classic P300)[3]. The P3a is a positive ERP with a latency of roughly 250 to 280 ms and normally observed in frontal/central region electrodes of EEG. The P3b is also a positive ERP with a maximum amplitude peaking at around

300 ms (varying in 250-500 ms), and it normally occurs 75-100 ms later than the P3a. Even though the two components have different functional sensitivities and associated psychological correlates, both of them are significant for brain research.

ERPs have been mostly measured and monitored in two methods, Electroencephalography (EEG) and Magnetoencephalography (MEG). In conventional scalp EEG measurement system, the electrodes are placed on the scalp with a conductive gel or paste. Electrode locations and number are decided by the measurement objective and demand of spatial resolution. In order to obtain more accurate data, the scalp area need to be clean to reduce impedance due to dead skin cells before the measurement. In MEG hand, arrays of SQUIDS (Superconducting Quantum Interference Devices) are currently the most common magnetometer used to measure extremely subtle magnetic fields. SQUIDS are highly sensitive, however, based on current superconducting technology, to maintain superconductivity, the entire device needs to be cooling in liquid nitrogen or liquid helium environment. Otherwise SQUIDS are usually set up in a magnetic shielded room and it makes the device inconvenient.

Comparing with the EEG electrodes and the SQUIDS, Magneto-Impedance sensor (MI sensor) is smaller, lower cost and no need for magnetic shielding. Based on past work we reported previously, in this study, we recorded the P300 brain waves in the parietal region by MEG using a picotesla-scale MI sensor. Then we compared our results with EEG and MEG data reported previously and considered the reliability of our data. Otherwise, we did a trial measurement of P3a and P3b using two MI sensors.

II. MATERIALS AND METHODS

MI measurement system

The MI sensor used in this study was a highly sensitive magnetometer based on pulse-current magneto-impedance effect in FeCoSiB amorphous wires[4]. Fig. 1 shows the structure of the FeCoSiB amorphous wire, which is the core component of the MI sensor head. Fig. 2 shows the measurement system of the MI sensor. The entire device was fixed on a four-joint support arm, which could be rotated in 360 degrees. The system consists of three parts: sensor head, measurement circuit and analog filter circuit.

Fig. 3 shows the sensor head. In this system, one sensor head included two MI elements, a measuring one used to

measure the total magnetic field (brain magnetic field plus background magnetic noise) and a reference one used to cancel out the background magnetic noise such as geomagnetism. The voltage difference between those two MI elements was used as output and the distance between those two MI elements was 3 cm. Fig. 4 illustrates the schematic diagram of the MI sensor measurement system.

In analog filter level, in order to decrease the commercial power source noise, a 60 Hz notch filter was set up to the system. And the system also contained a 45 Hz low-pass filter to remove high frequency components.

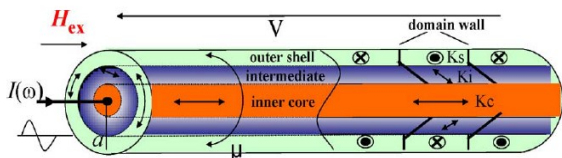

Fig. 1 Domain structure of amorphous alloy wire.

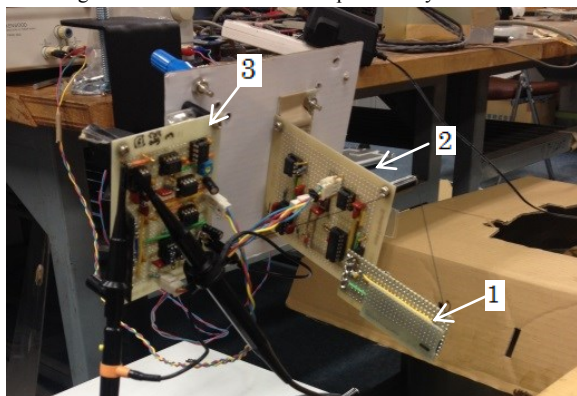

Fig. 2 1: MI sensor head. 2: Measurement circuit. 3: Analog filter circuit.

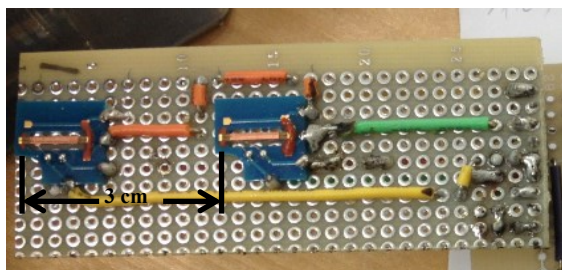

Fig. 3 MI sensor head.

Methods

1. Subjects

Three subjects (two males and one female) between the ages of 21 and 28 years with normal auditory perception and no neurological or psychiatric problems reported.

2. Stimuli

The P300 ERP is often elicited with a two-stimulus discrimination task (i.e. two-stimulus oddball paradigm)[5]. In this study, we presented two kinds of auditory stimuli using a microcontroller, low probability ($p=0.2$) target stimuli (2000 Hz) and high probability ($p=0.8$) standard stimuli (1000 Hz).

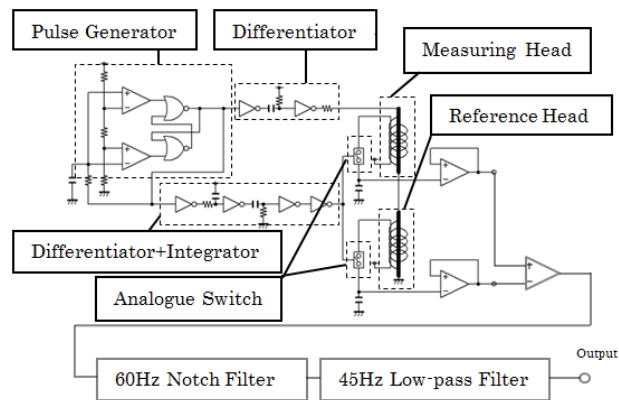

Fig.4 MI sensor measurement system schematic diagram.

3. Procedures

Subject lay comfortably on a wooden bed with relaxation of mind and put his/her index finger on a response button. The MI sensor was set above the parietal region (position Pz in the international 10-20 system) of subject for contactless measurement. The distance between MI sensor head and the scalp of subject was 5 mm. In this discrimination task, subject kept his/her eyes open (blinking was acceptable), a total of 300 stimuli (one time 30 stimuli and repeated 10 times) for each subject were occurred in a random series once every 1.5 seconds, and subject was instructed to indicate the occurrence of a target stimulus as quickly and accurately as possible by pressing the response button.

4. Data processing

Output signal of the measurement system was recorded by a data logger with a 1000 Hz sampling rate. In digital signal processing, in order to observe the ERP, a digital filter based on the arithmetic mean and the FFT/IFFT was implemented to reduce the components of noise. For each test, 60 target conditions and 240 standard conditions were available, and we chose 30 conditions with no artifact for arithmetic averaging respectively. Furthermore, the digital filter removed the signal components beyond 1.5-30 Hz.

5. Trial measurement of P3a and P3b

As a trial measurement, different from the P300 measurement, only one subject (24 years old female) was involved in this test; A three-stimulus auditory oddball paradigm (target stimuli: 2000 Hz, $p=0.2$; distractor stimuli: 1500 Hz, $p=0.067$; standard stimuli: 1000 Hz, $p=0.733$) was used to elicit the P3a and P3b; In this measurement, we placed two MI sensor above the parietal region (position Pz in the international 10-20 system) and the frontal/central region (position between Fz and Cz in the international 10-20 system) of subject; A total of 600 stimuli (one time 30 stimuli and repeated 20 times) were occurred in a random series once every 1.5 seconds; In digital signal processing, for each test, 120 target conditions, 40 distractor conditions and 440 standard conditions were available, and we chose 30 target and standard conditions, 20 distractor conditions with no artifact for arithmetic averaging respectively.

III. RESULTS

A. P300 measurement

The data of both target conditions and standard conditions were processed in the same fashion. The waveforms of three subjects' brain activity are shown respectively in Fig.5 (a), (b) and (c). Each graph presents the mean P300 ERP elicited by target and standard stimuli from the two-stimulus oddball paradigm. The results show that the positive deflections with a latency of approximately 250 to 400 ms can be elicited by target stimuli appreciably but barely elicited by standard stimuli, and the three graphs presented common characteristics.

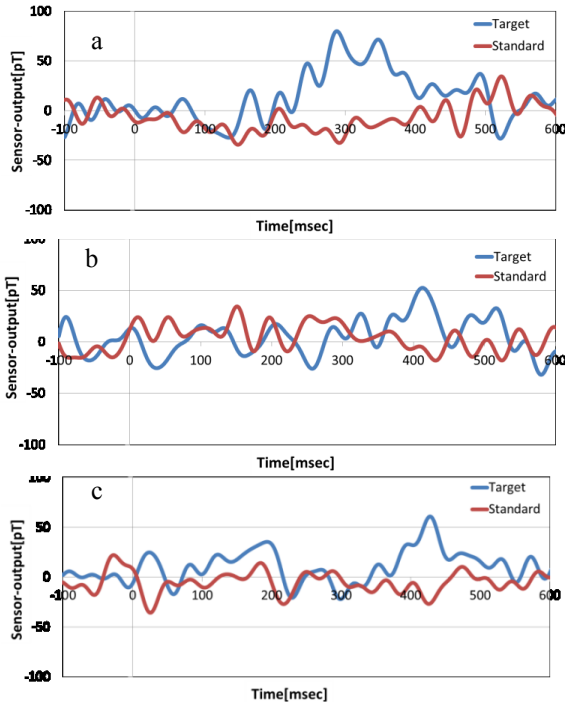

Fig.5 Mean P300 ERP elicited by target and standard stimuli from the oddball paradigm.

B. P3a and P3b measurement

The waveforms from two sensors, which set up above the frontal/central region and the parietal region, are shown respectively in Fig.6 (a) and (b). The graph Fig. 6 (a) presents that in the frontal/central region, the P3a was obviously elicited by distractor stimuli with a latency of 270 ms and the P3b was obviously elicited by target stimuli with a latency of 310 ms. In Fig. 6 (b), the P3b was obviously elicited by target stimuli with a latency of 300 ms, however, the P3a was barely elicited by distractor stimuli.

IV. DISCUSSION

A. P300 measurement

In P300 ERP measurement, three subjects performed the two-stimulus oddball task and the results show similar characteristics. Fig. 7 (a) and (b), which we reported in the past work[6], show the waveforms of mean P300 ERP elicited by target and standard stimuli in occipital region and waveforms of 3 times repeated measurement of the same subject.

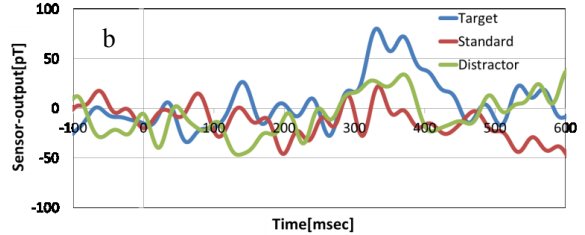
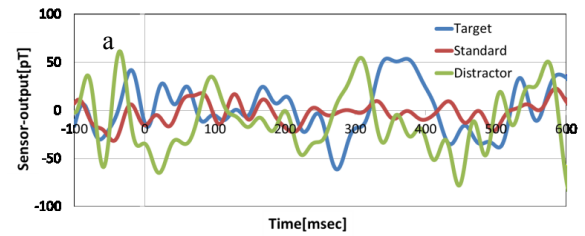

Fig.6 Mean P3a and P3b trial measurement from the three-stimulus oddball paradigm. (a) is the waveforms from frontal/central region sensor, (b) is the waveforms from parietal region sensor.

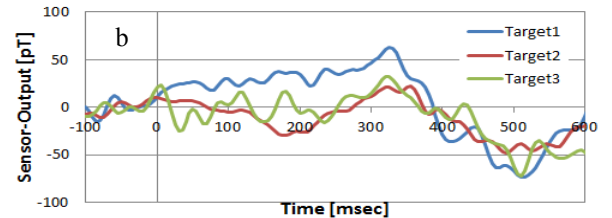
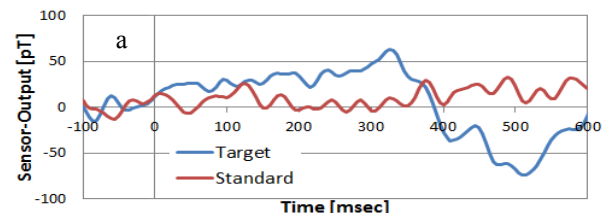

Fig.7 The waveforms of ERP we reported in past work. (a) shows the waveforms of mean P300 ERP elicited by target and standard stimuli in occipital region. (b) shows the waveforms of 3 times repeated measurement of the same subject.

The waveforms clearly possess similar characteristics with the waveforms shown in Fig. 5.

Then we compared our data with other P300 ERP relevant research results[7][8], which detected the brain activity by EEG electrodes and arrays of SQUIDS, the waveforms show the similar characteristics with our data, even though there is a minute difference in amplitude and latency time due to different objective and subject situation.

B. P3a and P3b measurement

We also compared our data with other P3a and P3b relevant research results[9] which detected the brain activity by EEG electrodes (they also utilized fMRI). The results present the similar characteristics of both the P3a and the P3b in frontal/central region, but in the parietal region, only the P3b is similar

As a trial measurement, the results of the frontal/central region were similar but the results of the parietal region have some difference with other relevant research results. We also reviewed our experimental methods and environment, and we think there is a possibility that the discrimination between the three kinds of auditory stimuli was easy to identify that caused the slight P3a. On the other hand, only one subject was involved in this test, and the ERP amplitude is related to the subject situation. We will run more tests to verify our results in subsequent research.

C. MI sensor measurement system

The main goal of this study was to review the performance of MI sensor on brain activity detection and the results proved that the MI sensor could be used in MEG measurement. In order to obtain more accurater data and reduce the measurement time, we also plan to increase the number of sensors, which decided by the measurement objective. Moreover, biosignals measurement normally contains a lot of noise generated by our bodies such as blood flow, breath and eyeball movement, reducing those noise will be one of our targets for further improvement.

D. The magnitude of the magnetic field

Fig.8 shows the sketch of the measurement model. In this model, we treat the brain surface locally as a plane. The Q is the brain current dipole source, the red arrows represent the current direction (dash line is return current). Assuming the distance between current dipole source and the return current is D . The distance between the cerebral cortex and the MI sensor head is z . The Z direction magnetic field (B_z) generated by a current dipole located within a horizontally layered conductor

$$B_z = \frac{\mu_0 Q \times (\mathbf{r} - \mathbf{r}_Q) \cdot \mathbf{e}_z}{4\pi |\mathbf{r} - \mathbf{r}_Q|^3} \quad (1)$$

is given by [10, equation 35]

$$B_z(x, D, z) = B_z^0(x, z) + B_z^+(x, D, z) + B_z^-(x, D, z), \quad (2)$$

$$B_z^0(x, z) = \frac{\mu_0 Q}{4\pi} \frac{x}{\sqrt{(x^2 + z^2)^3}}, \quad (3)$$

$$B_z^+(x, D, z) = \frac{\mu_0 Q}{4\pi} \frac{D - x}{2 \sqrt{((D - x)^2 + z^2)^3}}, \quad (4)$$

$$B_z^-(x, D, z) = \frac{\mu_0 Q}{4\pi} \frac{-D - x}{2 \sqrt{((D + x)^2 + z^2)^3}}, \quad (5)$$

The B_z along x axis are as follows:

where μ_0 is the vacuum permeability. Using this model on SQUIDS, the z is about 60 mm, assuming the Q is 100 nAm[11], D is 20 mm, and the maximum value of magnetic field is estimated as 0.18 pT when x is 10.8 mm (experimental value is about 0.2 pT [8, Fig.3]). Then using the same model on MI sensor, z is about 15 mm (the distance between cerebral cortex and scalp is roughly 10 mm). the maximum value of magnetic field B_z is estimated as 21.71 pT and it is about 120 times bigger than the estimated value of SQUIDS.

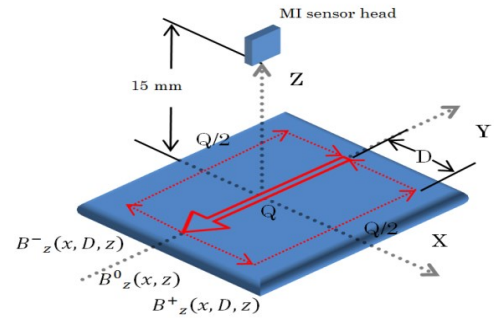

Fig. 8 sketch of the MI sensor measurement model

V. CONCLUSION

In this study, we detected the brain activity in the parietal region using a MI sensor, and after comparing our results with other relevant researches, the reliability of our data was confirmed and it suggested that the MI sensor can be used in detection of brain activity.

ACKNOWLEDGMENT

We would like to thank Aichi Steel Coroiration for manufacturing the MI sensor head which we used in this study.

REFERENCE

- [1] Luck, Steven J. (2005), "An Introduction to the Event-Related Potential Technique," The MIT Press. ISBN 0-262-12277-4.
- [2] Polich, J. (2007), "Updating P300: An integrative theory of P3a and P3b," *Clinical Neurophysiology*, 118(10), 2128-2148.
- [3] Squires, N.K., Squires, K.C., & Hillyard, S.A. (1975), "Two varieties of long-latency positive waves evoked by unpredictable auditory stimuli in man," *Electroencephalography & Clinical Neurophysiology*, 38, 387-401.
- [4] T. Uchiyama, K. Mohri, Y.Honkura, and L.V. Panina, "Recent advances of pico-Tesla resolution Magneto-Impedance Sensor based on amorphous wire CMOS IC MI Sensor," *IEEE Transactions on magnetics*, VOL. 48, NO. 11, NOVEMBER 2012.
- [5] J. Polich ,and C.Margala, "P300 and probability: comparison of oddball and single-stimulus paradigms," *International Journal of Psychophysiology* 25 (1997)169-176.
- [6] S. Tajima, T. Uchiyama, Y. Okuda, and K. Wang, "Brain activity measurement in the occipital region of the head using a magneto-impedance sensor," 2013 Seventh International Conference on Sensing Technology (ICST), 267-270.
- [7] J.Y. Bennington, and J.Polich, "Comparison of P300 from passive and active tasks for auditory and visual stimuli," *International Journal of Psychophysiology* 34 (1999) 171-177.
- [8] A. Mecklinger, B. Maess, B. Opitz, E. Pfeifer, D. Cheyne, and H. Weinberg, "A MEG analysis of the P300 in visual discrimination tasks," *Electroencephalography and clinical Neurophysiology* 108 (1998) 45-56.
- [9] C. Bledowski, D.Prvulovic, R.Goebel, F.E.Zanella, and D.E.J.Linden, "Attentional systems in target and distractor processing: a combined ERP and fMRI study," *NeuroImage* 22 (2004) 530- 54.
- [10] Matti Hämäläinen, Riitta Hari, Risto J. Ilmoniemi, Jukka Knuutila, and Olli V. Lounasmaa, "Magnetoencephalography, theory, instrumentation, and applications to noninvasive studies of the working human brain," *Rev. Mod. Phys.* 65, 413 - Published 1 April 1993
- [11] T. maeno, A. kaneko, K. Iramina, F. Eto, and S. Ueno, "Source modeling of the P300 event-related response using magnetoencephalography and electroencephalography measurements," *IEEE TRANSACTIONS ON MAGNETICS*, VOL. 39, NO. 5, SEPTEMBER 2003.