

論文 / 著書情報
Article / Book Information

Title	Estimating maximum responses and control force for equivalent input disturbance approach based active structural control
Authors	K. Miyamoto, D. Sato, Y. Chen, J. She
Pub. date	2020, 9
Citation	2020 17WCEE Proceedings



Estimating maximum responses and control force for equivalent input disturbance approach based active structural control

Kou Miyamoto⁽¹⁾, Daiki Sato⁽²⁾, Yinli Chen⁽³⁾, and Jinhua She⁽⁴⁾,

⁽¹⁾ Researcher, Shimizu corporation, kou_miyamoto@shinz.co.jp

⁽²⁾ Associate professor, Tokyo Institute of Technology, sato.d.aa@m.titech.ac.jp

⁽³⁾ Ph. D candidate, Tokyo Institute of Technology, chen.y.at@m.titech.ac.jp

⁽⁴⁾ Professor, Tokyo university of technology, she@stf.teu.ac.jp

Abstract

In this few decades, active structural control has been studied rapidly and employed in some structures. An active structural control method is the combination of the control engineering and structural engineering. Most studies have used a feedback control method. The feedback control method improves the dynamic characteristics of the control system. On the other hand, an equivalent-input-disturbance (EID) approach consists of not only the feedback controller but also the feedforward controller. Since the feedforward controller suppresses a disturbance directly, the control performance of the system is better than that of the common feedback control system. The EID method is extended to suppresses not only the displacement but also the absolute acceleration, which are the most important for active structural control for buildings. However, EID based control system includes both the feedforward control and the feedback control. Thus, many parameters have to be tuned and trial and error method is used to design the control system.

In passive structural-control approach, the response spectrum method, which estimates the maximum displacement, velocity and absolute acceleration is used to design the control system.

This paper presents new the response spectrums and control force spectrum, which estimates the maximum required control force for designing the EID based active structural control system.

Keywords: Active control, Equivalent input disturbance, Structural control

1. Introduction

In this few decades, the number of structure that employs a passive base isolation has been increased rapidly [1]. Furthermore, some structures use not only the passive base isolation but also an active structural-control method. A linear quadratic regulator (LQR) is one of the most common method to design the state feedback controller. The LQR method designs a feedback controller by optimizing a cost function that includes the response of the structure and the control force [2]. From stand point of protecting both the people and the building, some studies consider the kinetic energy [3] or the absolute acceleration and the inter story drift [4]. The state feedback controller adjusts the dynamic characteristics of the control system.

On the other hand, an equivalent-input-disturbance (EID) approach, which is devised by She et al. has not only the feedback controller but also the feedforward controller, and the feedforward controller suppresses the disturbance directly [5]. This method estimates an EID that outputs the same influence of the original disturbance, and the EID estimator is plugged in the conventional feedback control system.

Fang et al. and She et al. applied the EID for active control of a building and shows that the control performance of the EID based active control system is better than that of the LQR and the sliding-mode control system [6]. Miyamoto et al. show that the EID control system suppresses the



low frequency waves, which is the most important for the structure especially for high-rise buildings [7]. From the view point of protecting the building, Miyamoto et al. presented an extended EID (EEID) control method that suppresses not only the displacement but also the absolute acceleration [8].

However, since the EEID based control system contains both the feedback and the feedforward controller, many parameters have to be tuned to design the control system, and these parameters are decided by the trial-and-error method.

In passive structural-control approach, the responses spectrum method, which estimates the maximum displacement, velocity and the absolute acceleration, is one of the most common method to design the control system.

Sato et al. extended the new response and control force spectrum that estimates the maximum responses and the control force for state feedback control systems [9].

This study presents a new responses and control force spectrums that estimate the maximum displacement, velocity, absolute acceleration and the maximum control force for the EEID based control system that has both the feedback and feedforward controller.

2. EID and EEID methods

This section explains the distinction between the conventional EID method and the EEID method, which suppresses the absolute acceleration.

2.1. Definition of EID and EEID

The equation of motion of a shear building model with active structural control is described by:

$$M_S \ddot{x}(t) + D_S \dot{x}(t) + K_S x(t) = -M_S \{1\} \ddot{x}_g(t) + E_u u(t), \quad (1)$$

where M_S is a mass matrix, D_S is a damping matrix, K_S is a stiffness matrix, $u(t)$ is control force and E_u is a placement of active structural control devices. The state space representation of (1) is:

$$\begin{cases} \dot{z}(t) = Az(t) + Bu(t) + B_d d(t) \\ y_w(t) = Cz(t), \end{cases} \quad (2)$$

where:

$$\begin{cases} z(t) = \begin{bmatrix} x(t) \\ \dot{x}(t) \end{bmatrix}, & A = \begin{bmatrix} 0 & I \\ -M_S^{-1}K_S & -M_S^{-1}D_S \end{bmatrix}, \\ B = \begin{bmatrix} B_1 \\ B_2 \end{bmatrix} = \begin{bmatrix} 0 \\ M_S^{-1}E_u \end{bmatrix}, & B_d = \begin{bmatrix} 0 \\ -\{1\} \end{bmatrix}, \\ d(t) = \ddot{x}_g(t). \end{cases} \quad (3)$$

A is the system matrix, which determines the dynamic characteristics of the system, B is the control input matrix, B_d is the disturbance input matrix, C is the output matrix, which means the placement and kind of sensors, $d(t)$ is a disturbance, and the $z(t)$ is the state of the control system. The block diagram of (2) is shown in Fig. 1. In Fig.1 s is a Laplace operator.

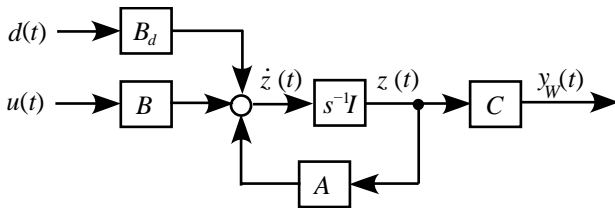

Fig. 1. Block diagram of equation (2).

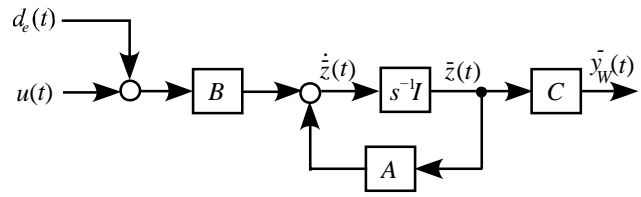

Fig. 2. Plant with a disturbance input in the control input channel.

We assume that if the disturbance inputs in the control input channel, B , the system is as shown in Fig. 2. For Figs. 1 and 2, an EID is defined as follows:

• *Definition 1:* If $y_w(t) = \bar{y}_w(t)$, then the $d_e(t)$ is defined as an EID. That is, an EID is a signal on the input channel that has the same effect as the original disturbance.

Although it is important to suppress both the displacement and the absolute acceleration for buildings, conventional EID systems do not consider the absolute acceleration.

Regrouping (1) gives the absolute acceleration of the control system:

$$\begin{aligned} \ddot{x}_g(t) + \{1\}\dot{x}(t) &= -K_S x(t) - D_S \dot{x}(t) + E_u u(t) \\ &= Cz(t) + Du(t). \end{aligned} \quad (4)$$

Therefore, the absolute acceleration can be represented by using the state, $z(t)$, and the control input, $u(t)$. The block diagram of a system that outputs the absolute acceleration is shown in Fig. 3 and the state space equation is (5):

$$\begin{cases} \dot{z}(t) = Az(t) + Bu(t) + B_d d(t) \\ y(t) = Cz(t) + Du(t). \end{cases} \quad (5)$$

Figure 3 shows that this system outputs the absolute acceleration. The output of the system with the direct-feedthrough matrix, D , is described as $y(t)$, and the output for the EID is described as $\bar{y}(t)$. The EID of this system, $d_e(t)$, suppresses the absolute acceleration and is called EEID [8].

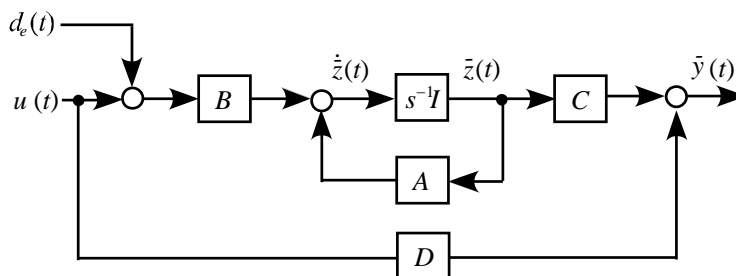

Fig. 3. Plant with EEID.

2.2. Estimate of EEID

The configuration of the EEID-based active structural control system is shown in Fig. 4. In this figure, $F(s)$ is a low-pass filter and B^+ is a pseudo inverse matrix of B .

$$B^+ = (B^T B)^{-1} B^T. \quad (6)$$

The state observer of the system with direct-feedthrough, (5), is:



$$\begin{cases} \dot{\hat{z}}(t) = A\hat{z}(t) + Bu(t) + L_p C\Delta z(t) \\ \hat{y}(t) = C\hat{z}(t) + Du(t), \end{cases} \quad (7)$$

where $\hat{z}(t)$ is the estimated $z(t)$ and $\Delta z(t)$ is an estimation error:

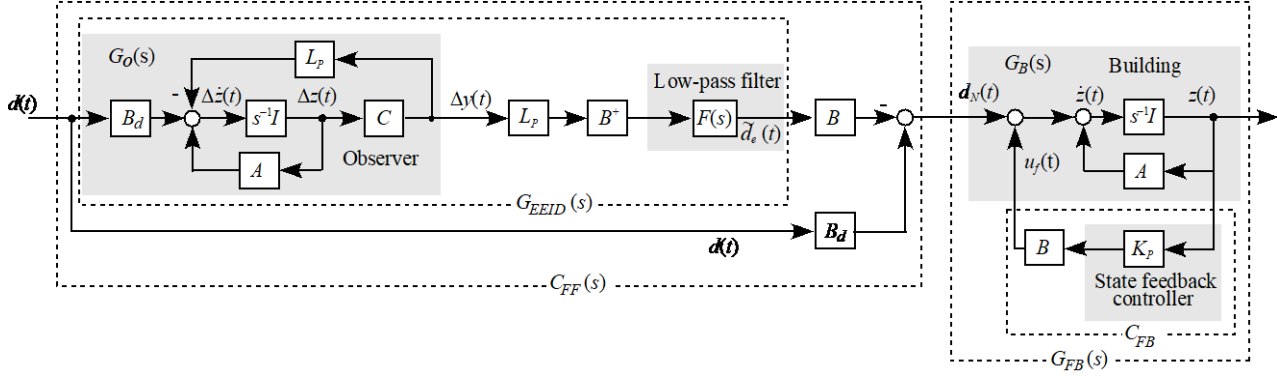

Fig. 4. Configuration of EEID system

$$\Delta z(t) = z(t) - \hat{z}(t) \quad (8)$$

Substituting (7) and (8) into (5) yields:

$$\begin{cases} \Delta \dot{z}(t) = (A - L_p C)\Delta z(t) + B d_e(t) \\ \Delta y(t) = C\Delta z(t). \end{cases} \quad (9)$$

Assumption 1 ensures the existence of a control input, $\Delta d(t)$, that satisfies:

$$\Delta \dot{z}(t) = A\Delta z(t) + B\Delta d(t). \quad (10)$$

Equations (10) and (9) yield:

$$B\hat{d}_e(t) = L_p C\Delta z(t), \quad (11)$$

where $\hat{d}_e(t)$ is the estimated EEID and it is given by:

$$\hat{d}_e(t) = d_e(t) - \Delta d(t) \quad (12)$$

(10) gives the estimated EID, $\hat{d}_e(t)$, is given by using B^+ :

$$\hat{d}_e(t) = B^+ L_p C\Delta z(t). \quad (13)$$

$\tilde{d}_e(t)$ is filtered by a low-pass filter, $F(s)$, and used as the control force of the system. The output of the low-pass filter is:

$$\tilde{D}_e(s) = F(s)\hat{D}_e(s), \quad (14)$$

where $\tilde{D}_e(t)$ is the Laplace transformed $\tilde{d}_e(t)$. In this paper, the following low-pass filter is used:

$$F(s) = \frac{N_F}{\Omega s + 1}, \quad (15)$$



where Ω is cut-off frequency and N_F is a gain of the filter such that $0 < N_F \leq 1$. The maximum control input can be adjusted by N_F , as explained in [7].

The control input,

$$u(t) = u_f(t) - \tilde{d}_e(t), \quad (16)$$

combines the state feedback control force, $u_f(t)$, and an inverse of the estimated EEID, $\tilde{d}_e(t)$. The control law of the state feedback control force, $u_f(t)$, is:

$$u_f(t) = \begin{bmatrix} K_{P1} & K_{P2} \end{bmatrix} \begin{bmatrix} x(t) \\ \dot{x}(t) \end{bmatrix} = K_P z(t). \quad (17)$$

The transfer function from the disturbance to the state, $z(t)$, which consists of the velocity and the displacement is

$${}_d G_z(s) = G_{FB}(s) C_{FF}(s). \quad (18)$$

2.3. Transfer function from disturbance to absolute acceleration

This section shows the transfer function from a disturbance to the absolute acceleration of the EEID-based control system.

Combining (1), (16) and (17) yields:

$$\begin{aligned} \ddot{x}(t) + \ddot{x}_g(t) &= -M_S^{-1} D_S \dot{x}(t) - M_S^{-1} K_S x(t) + M_S^{-1} E_u u_f(t) - M_S^{-1} E_u \tilde{d}_e(t) \\ &= -M_S^{-1} D_{Seq} \dot{x}(t) - M_S^{-1} K_{Seq} x(t) - \ddot{x}(t)_{EEID}, \\ &= C_{Acc} z(t) - \ddot{x}(t)_{EEID} \end{aligned} \quad (19)$$

where:

$$D_{Seq} = D_S + E_u K_{P,1} \quad (20)$$

$$K_{Seq} = K_S + E_u K_{P,2} \quad (21)$$

$$C_{Acc} = \begin{bmatrix} -M_S^{-1} D_{Seq} & -M_S^{-1} K_{Seq} \end{bmatrix}, \text{ and} \quad (22)$$

$$\ddot{x}_{EEID}(t) = B_2 \tilde{d}_e(t) = M_S^{-1} E_u \tilde{d}_e(t). \quad (23)$$

D_{Seq} and K_{Seq} describe the damping and stiffness matrices with active control respectively, C_{Acc} is the matrix that outputs the absolute acceleration, and $\ddot{x}(t)_{EEID}$ is the acceleration by the feedforward controller.

Since this system has feedback and feedforward controller, the effects of the two controllers have to be taken into account to calculate the absolute acceleration of the EEID-based control system.

The absolute acceleration of the feedback control system, $G_{FB}(s)$, is given by substituting $\ddot{x}_{EEID}(t) = 0$ into (19):

$$\ddot{x}(t) + \ddot{x}_g(t) = C_{Acc} z(t). \quad (24)$$



The state, $z(t)$, is given by using (18) and the Laplace transration of the earthquake, $s^2X_g(s)$ for earthquake waves obtained by using (24), is:

$$z(t) = L^{-1} \left[G_{FB}(s) C_{FF}(s) s^2 X_g(s) \right]. \quad (25)$$

Figure 1 shows that the estimated EEID is given by using the observer, $G_o(s)$, B^+ , L_P and the low-pass filter, $F(s)$:

$$\tilde{d}_e(t) = L^{-1} \left\{ F(s) B^+ L_P G_o(s) s^2 X_g(s) \right\}. \quad (26)$$

Therefore, $\ddot{x}_{EEID}(t)$ is:

$$\ddot{x}_{EEID}(t) = B_2 \tilde{d}_e(t) = L^{-1} \left\{ B_2 F(s) B^+ L_P G_o(s) s^2 X_g(s) \right\}. \quad (27)$$

The block diagram of the transfer function that output the absolute acceleration is shown in Fig. 5 by using (19) and (27).

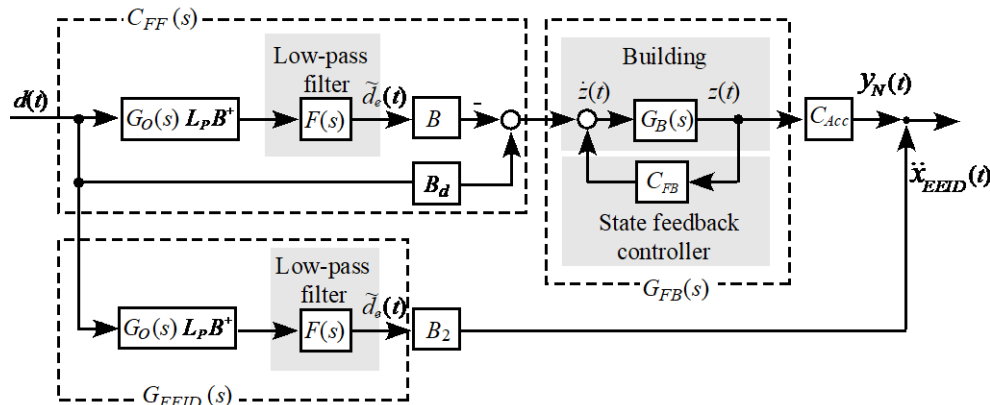

Fig. 5. Control system from EID to absolute acceleration.

3. Response spectrum and control force spectrum for EEID

This section explains the new spectrums, which estimate the maximum displacement, velocity, absolute acceleration, and the maximum control force of the EEID control system.

Since this paper uses a response spectrum method, a SODF model with and without active control input are considered (Fig. 6):

$$m_S \ddot{x}(t) + d_S \dot{x}(t) + k_S x(t) = -m_S \ddot{x}_g(t) - u(t) \quad (28a)$$

And

$$m_S \ddot{x}(t) + d_S \dot{x}(t) + k_S x(t) = -m_S \ddot{x}_g(t) \quad (28b)$$

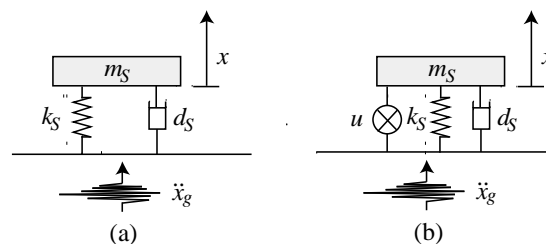

Fig. 6. SDOF model: (a) without active control and (b) with active control.



3.1. Response and control force spectrum for the feedback control system

The response-spectrum method estimates the maximum responses of buildings with the damping ratio and the natural frequency are h and ω_s . The spectrums are called displacement response spectrum, velocity response spectrum, and the absolute acceleration spectrum; and are represented $S_D(\omega_s, h)$, $S_V(\omega_s, h)$ and $S_A(\omega_s, h)$:

$$|x(t)|_{\max} \approx S_D(\omega_s, h) \quad (29a)$$

$$|\dot{x}(t)|_{\max} \approx S_V(\omega_s, h) \quad (29b)$$

and

$$|\ddot{x}(t) + \ddot{x}_g(t)|_{\max} \approx S_A(\omega, h), \quad (29c)$$

where, ω_s is the natural frequency of the system and it is given by:

$$\omega_s = \sqrt{\frac{k_s}{m_s}} \quad (30)$$

This spectrum is extended for velocity feedback-control system [9].

$$u(t) = K_p \dot{x}(t). \quad (31)$$

Substituting (31) into (28a) yields:

$$m_s \ddot{x}(t) + d_{seq} \dot{x}(t) + k_s x(t) = -m_s \ddot{x}_g(t), \quad (32)$$

where d_{seq} is the equivalent damping coefficient and is given by:

$$d_{seq} = d_s + K_p. \quad (33)$$

Thus, the feedback control adjusts the damping ratio of the control system. The damping ratio of the control system, h_{seq} , is given by the sum of the initial damping ratio, h_s , and the added damping ratio, h_k , by the feedback controller:

$$h_{eq} = \frac{d_s}{2m_s \omega_s} + \frac{K_p}{2m_s \omega_s} = h_s + h_k. \quad (34)$$

(34) indicates the responses of the active control system can be represented by using the common passive structural-control building model, which damping ratio is h_{eq} . Therefore, the responses of the active control system can be estimated by using the following response spectrum method.

$$|x(t)|_{\max} \approx S_D(\omega, h_{eq}) \quad (35)$$

$$|\dot{x}(t)|_{\max} \approx S_V(\omega, h_{eq}) \quad (36)$$

and

$$|\ddot{x}(t) + \ddot{x}_g(t)|_{\max} \approx S_A(\omega, h_{eq}) \quad (37)$$



Since the control force is given by the velocity and the feedback controller gain, which is shown in (31), the control force spectrum, $U(\omega, h_{eq})$, which estimates the maximum control force is defined as

$$U(\omega, h_{eq}) \approx K_p |\dot{x}(t)|_{\max} \approx K_p S_V(\omega, h_{eq}) \quad (38)$$

This spectrum depends on the weight of buildings. This paper uses following shear force spectrum of the control force that does not depend on the building weight:

$$C_U(\omega, h_{eq}) = \frac{K_p S_V(\omega, h_{eq})}{m_s g} = \frac{U(\omega, h_{eq})}{m_s g} \quad (39)$$

3.2. Displacement and velocity response spectrum for EEID control system

Section 2.3 shows the the new spectrums that estimate the maximum reponses and the control force of active structural control systems. These spectrums consider only the system that has only the feedback controller. However, as mentioned earlier above, the EEID control system has not only the feedback controller but also the feedforward controller. This section presents new spectrums tha are for the EEID control system.

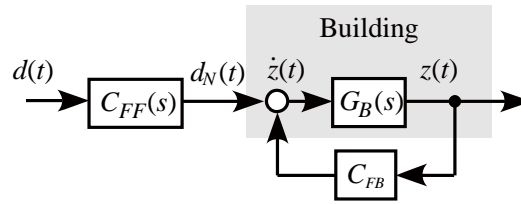

Fig. 7. Simplification of Fig. 4.

Figure 8 shows the simplification of Fig.5. Figure 8 represents that the appropriate feedforward controller $C_{FF}(s)$ suppresses the disturbance from $d(t)$ to $d_N(t)$. $d_N(t)$ can be calculated by using the Fourier transform of the disturbance, $d(t)$, and the transfer function of the feedforward controller, $C_{FF}(s)$. Thus the displacement and the velocity reponses spectrums for EEID control system, $S_{D,EEID}(\omega_s, h_{eq})$ and $S_{V,EEID}(\omega_s, h_{eq})$ can be obtained easliy

3.3. Absolute acceleration and control force spectrums

The EEID-based control system adds a new term $\ddot{x}_{EEID}(t)$ to $y_N(t)$. This makes the following rule of thumb not hold any more:

$$S_A(\omega_s, h) \approx \omega_s S_V(\omega_s, h) \quad (40)$$

The absolute acceleration of the EEID-based control system is given by:

$$\ddot{x}(t) + \ddot{x}_g(t) = y_N(t) + \ddot{x}_{EEID}(t) \quad (41)$$

The absolute sum (ABS) and root sum of square (RSS) of $y_N(t)$ and $\ddot{x}_{EEID}(t)$ are shown in (54a,b) :

$$ABS_{Acc} = |\ddot{x}_{EEID}(t)|_{\max} + |y_N(t)|_{\max} \quad (42a)$$

$$RSS_{Acc} = \sqrt{|\ddot{x}_{EEID}(t)|_{\max}^2 + |y_N(t)|_{\max}^2} \quad (42b)$$



Since $y_N(t)$ is the absolute acceleration of the feedback control system for $d_N(t)$, the maximum response can be estimated by using (43):

$$\max |y_N(t)| \approx \omega_S S_{V,EEID}(\omega_S, h) \quad (43)$$

The equation of motion of a building when an EEID, $d_e(t)$, inputs is shown in (44):

$$m_S \ddot{\bar{x}}(t) + d_S \dot{\bar{x}}(t) + k_S \bar{x}(t) = -d_e(t). \quad (44)$$

An EEID is a signal on the input channel and it has the same effect as the original disturbance. Thus, the following relationship exists between (28a) and (28b):

$$x(t) = \bar{x}(t). \quad (45)$$

(28a), (28b) and (45) yield:

$$m_S \ddot{x}_g(t) = d_e(t). \quad (46)$$

As (14) shows that the filtered EEID, $\tilde{d}_e(t)$, is used and it is given by:

$$\tilde{d}_e(t) \approx N_F d_e(t) = N_F m_S \ddot{x}_g(t). \quad (47)$$

Substituting (47) into (27) yields the acceleration by using the feedforward controller:

$$\ddot{x}_{EEID}(t) = B_2 \tilde{d}_e \approx N_F \ddot{x}_g \quad (48)$$

This paper estimates the maximum absolute acceleration of an EEID system by using the average of ABS_{ACC} and RSS_{ACC} :

$$\begin{aligned} |\ddot{x}(t) + \ddot{x}_g(t)|_{\max} &\approx \left\{ \frac{ABS_{ACC} + RSS_{ACC}}{2} \right\} \\ &= \frac{\left\{ N_F |\ddot{x}_g(t)|_{\max} + |y_N(t)|_{\max} \right\} + \sqrt{\left\{ N_F |\ddot{x}_g(t)|_{\max} \right\}^2 + |y_N(t)|_{\max}^2}}{2} \end{aligned} \quad (49)$$

Substituting (43) into (49) gives the absolute acceleration spectrum for the EEID control system, $S_{A,EEID}(\omega_S, h)$:

$$S_{A,EEID}(\omega_S, h_{eq}) = \frac{\left\{ N_F |\ddot{x}_g(t)|_{\max} + \omega_S S_{V,EEID}(\omega_S, h_{eq}) \right\} + \sqrt{\left\{ N_F |\ddot{x}_g(t)|_{\max} \right\}^2 + \left(\omega_S S_{V,EEID}(\omega_S, h_{eq}) \right)_{\max}^2}}{2} \quad (50)$$

The control force of this system consists of the two signals, namely, the feedback control input, $u_f(t)$, and the estimated EEID, $\tilde{d}_e(t)$. The ABS and RSS of the maximum feedback-control input, $u_f(t)$, and $\tilde{d}_e(t)$ are described using (51a) and (51b):

$$\begin{aligned} ABS_U &= |u_f(t)|_{\max} + |\tilde{d}_e(t)|_{\max} \\ &= K_P S_V(\omega_S, h_{eq}) + N_F m_S |\ddot{x}_g(t)|_{\max} \end{aligned} \quad (51a)$$

and



$$\begin{aligned}
 RSS_U &= \sqrt{|u_f(t)|_{\max}^2 + |\tilde{d}_e(t)|_{\max}^2} \\
 &= \sqrt{\{K_P S_V(\omega_S, h_{eq})\}^2 + \{N_F m_S |\ddot{x}_g(t)|_{\max}\}^2}.
 \end{aligned} \tag{51b}$$

Therefore, a control-force spectrum that estimates the maximum control input $U(\omega, h_{eq})$ is defined as:

$$U_{EEID}(\omega_S, h_{eq}) = \frac{\{K_P S_V(\omega_S, h_{eq}) + N_F m_S |\ddot{x}_g(t)|_{\max}\} + \sqrt{\{K_P S_V(\omega_S, h_{eq}) + \{N_F m_S |\ddot{x}_g(t)|_{\max}\}^2}}{2}. \tag{52}$$

Thus, the shear force spectrum for the control force, $C_{U,EEID}(\omega, h_{eq})$, which indicates the ratio of the maximum control force is

$$C_{U,EEID}(\omega_S, h_{eq}) = \frac{U_{EEID}(\omega_S, h_{eq})}{m_S g}. \tag{53}$$

4. Numerical example

This section validates our method through a numerical example. Since this paper devises new response and control force spectrums, this paper uses a SDOF model to demonstrate the validity of our method. The parameters of the active control system and buildings are as follows:

Damping ratio of the structure, h_u : 0.02

Damping ratio of the observer, h_o : 0.8

Equivalent damping ratio of the feedback control system, h_{eq} : 0.2, 0.4, and 0.6

Initial ordinal frequency of the observer, f_o : 10

Cutoff frequency, Ω : 0.01

Gain of the low-pass filter, N_F : 0.5.

The feedback controller gain, K_p , is designed by minimizing the following cost function:

$$J = \int \{z(t)Qz^T(t) + u(t)Ru(t)\}dt, \tag{54}$$

where $Q (> 0)$ and $R (> 0)$ are the weighting matrices for the state and the control force. This study uses the following weights:

$$Q = \begin{bmatrix} 0 & 0 \\ 0 & q \end{bmatrix} \text{ and} \tag{55a}$$

$$R = 1. \tag{55b}$$

The controller gain, K_p , is given by

$$K_p = -R^{-1}B^T P, \tag{56}$$

where $Q (> 0)$ and $R (> 0)$ are the weighting matrices for the state and the control force, and P is the solution of the following Riccati equation:

$$AP + PA - PB_u R B_u^T P + Q = 0. \tag{57}$$



The observer gain, L_p , is designed using the pole placement method by Ackerman's formula for the output matrix $C_o = [-k_s/m_s \quad -d_s/m_s]$:

$$L_p = [0 \quad 1]U_C^{-1}P(A) \quad (58a)$$

$$U_C^T = [C^T \quad A^T C^T] \text{ and} \quad (58b)$$

$$P(A) = \{A^2 - 2a_o A + (a_o^2 + b_o^2)I\}^T \quad (58c)$$

Table 1. Earthquake accelerograms list.

No.	M	Year	Record No.	Lowest freq. (Hz)	Component 1	Component 2	PGA max (g)	PGV max(cm/s)
1	6.7	1994	953	0.25	NORTHR/MUL009	NORTHR/MUL279	0.52	63
2	6.7	1994	960	0.13	NORTHR/LOS000	NORTHR/LOS270	0.48	45
3	7.1	1999	1602	0.06	DUZCE/BOL000	DUZCE/BOL090	0.82	62
4	7.1	1999	1787	0.04	HECTOR/HEC000	HECTOR/HEC090	0.34	42
5	6.5	1979	169	0.06	IMPVALL/H-DLT262	IMPVALL/H-DLT352	0.35	33
6	6.5	1979	174	0.25	IMPVALL/H-E11140	IMPVALL/H-E11230	0.38	42
7	6.9	1995	1111	0.13	KOBE/NIS000	KOBE/NIS090	0.51	37
8	6.9	1995	1116	0.13	KOBE/SHI000	KOBE/SHI090	0.24	38
9	7.5	1999	1158	0.24	KOCAELI/DZC180	KOCAELI/DZC270	0.36	59
10	7.5	1999	1148	0.09	KOCAELI/ARC000	KOCAELI/ARC090	0.22	40
11	7.3	1992	900	0.07	LANDERS/YER270	LANDERS/YER360	0.24	52
12	7.3	1992	848	0.13	LANDERS/CLW-LN	LANDERS/CLW-TR	0.42	42
13	6.9	1989	752	0.13	LOMAP/CAP000	LOMAP/CAP090	0.53	35
14	6.9	1989	767	0.13	LOMAP/G03000	LOMAP/G03090	0.56	45
15	7.4	1990	1633	0.13	MANJIL/ABBAR--L	MANJIL/ABBAR--T	0.51	54
16	6.5	1987	721	0.13	SUPERST/B-ICC000	SUPERST/B-ICC090	0.36	46
17	6.5	1987	725	0.25	SUPERST/B-POE270	SUPERST/B-POE360	0.45	36
18	7	1992	829	0.07	CAPEMEND/RIO270	CAPEMEND/RIO360	0.55	44
19	7.6	1999	1244	0.05	CHICHI/CHY101-E	CHICHI/CHY101-N	0.44	115
20	7.6	1999	1485	0.05	CHICHI/TCU045-E	CHICHI/TCU045-N	0.51	39
21	6.6	1971	68	0.25	SFERN/PEL090	SFERN/PEL180	0.21	19
22	6.6	1976	125	0.13	FRIULI/A-TM2000	FRIULI/A-TM270	0.35	31

Figure 8 compares $S_{A,EEID}(\omega_s, h_{eq})$, which estimates the maximum absolute acceleration of the EEID control system, and the time history analysis; and Fig. 9 compares $S_{C,EEID}$ and the time history analysis for 44 earthquake waves.

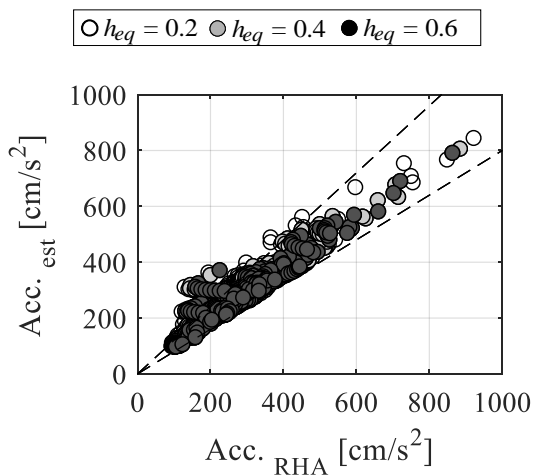

Fig. 8. Comparison of estimation and analysis for maximum absolute acceleration.

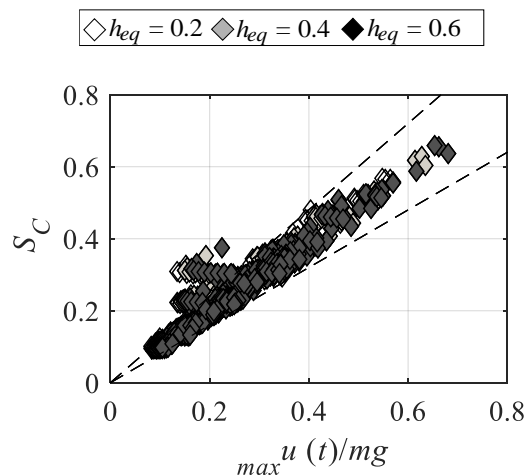

Fig. 9. Comparison of estimation and analysis for maximum control force.



Figures 8 and 9 show that our method satisfactorily estimated the maximum absolute acceleration and the maximum shear force of the control force for $T_u = 0.5\text{--}5.0$ s models.

5. Conclusion

This paper extends the response and control forcespectrum method for the EEID control system, which contains both the feedforward and feedback controller. The new method makes it easy to design the EEID based active structural control system. Usually, the absolute acceleration response spectrum can be estimated by using the velocity response spectrum and the natural frequency. However, since to consider the effect of using the feedforward controller, the absolute acceleration response spectrum cannot be given by multiplying the velocity response spectrum and the natural frequency of the system.

The absolute acceleration spectrum is given by considering the common absolute acceleration spectrum and the effect of EEID, and the maximum control force can be estimated by using the absolute sum (ABS) and root sum of square (RSS).

6. References

References must be cited in the text in square brackets [1, 2], numbered according to the order in which they appear in the text, and listed at the end of the manuscript in a section called References, in the following format:

- [1] The Japan Society of Seismic Isolation. Recent trends in seismic isolation buildings. <<http://www.jssi.or.jp/menshin/doc/keizoku2.pdf>> [in Japanese].
- [2] Wodek K. Gawronski (2004). *Advanced Structural Dynamics and Active Control of Structures*, Springer,
- [3] Aldemir U, Yanik A, Mehmet B (2012): Control of structural response under earthquake excitation. *Comput-Aid Civil Infrastructure Engineering*, **27**, 620–38.
- [4] Kou Miyamoto, Daiki Sato and Jinhua She (2018): A new performance index of LQR for combination of passive base isolation and active structural control. *Engineering Structures*, 157, 280-299
- [5] Jin-Hua She, Xin Xin and Yaodong Pan (2011): Equivalent-input-disturbance approach – analysis and application to disturbance rejection in dual-stage feed drive control system. *IEEE/ASME Trans Mechatron*, **16**(2), 330-340.
- [6] Mingxing Fang, Lijun Wu and Jing Cheng, Youwu Du, and Jinhua She (2016): Active Structural Control Based on Integration of H^∞ Control and Equivalent-Input-Disturbance Approach, *Journal of advanced computational intelligence and intelligent informatics*, **2**(20), 197-204.
- [7] Kou Miyamoto, Jinhua She, Junya Imani, Xin Xin, and Daiki Sato (2016): Equivalent-input-disturbance approach to active structural control for seismically excited buildings, *Engineering Structures*, **125**, 392-399.
- [8] Kou Miyamoto, Daiki Sato, and Jinhua She (2019): A new equivalent-input-disturbance approach for active control of building, *AIJ, Journal of Structural and Construction engineering*, 84(757), 361- 371
- [9] Daiki Sato, Yinli Chen, Kou Miyamoto, and Jinhua She (2019): A spectrum for estimating the maximum control force for passive-base-isolated buildings with LQR control, *Engineering Structures*, **199**.