

論文 / 著書情報
Article / Book Information

題目(和文)	
Title(English)	Appropriation of Tokyo through the Spatial Practices of Migrant Commonalities
著者(和文)	RAHMANAmena
Author(English)	Amena Rahman
出典(和文)	学位:博士(学術), 学位授与機関:東京工業大学, 報告番号:甲第11850号, 授与年月日:2022年3月26日, 学位の種別:課程博士, 審査員:塚本 由晴,安田 幸一,奥山 信一,山崎 鯛介,塩崎 太伸
Citation(English)	Degree:Doctor (Academic), Conferring organization: Tokyo Institute of Technology, Report number:甲第11850号, Conferred date:2022/3/26, Degree Type:Course doctor, Examiner:,,,,,
学位種別(和文)	博士論文
Type(English)	Doctoral Thesis

Appropriation of Tokyo through the Spatial Practices of Migrant Commonalities

Doctoral thesis
Yoshiharu Tsukamoto Laboratory

Tokyo Institute of Technology
Department of Architecture and Building Engineering

Amena Nadeem Rahman 2021

Acknowledgements:

I would like to thank Professor Tsukamoto for allowing me to conduct my research in his lab, and assistant professor Kei Sasaki for his advice. I am especially grateful to Davina Iwana for the collaboration; as well as Noemi Gomez-Lobo and Diego Martin-Sanchez for their invaluable feedback; Maliha Naeem and Raazia Hasnain for their unwavering support; Hyunsoo Kim for his advice; and all my colleagues in Tsukamoto Laboratory for their friendly attitude. My warm thanks to my family for their unquestioning encouragement.

This research was possible due to the financial support of the MEXT scholarship provided by the Japanese Ministry of Education.

Thesis Abstract:

Commonalities, which contain collective knowledge and recursive behaviours that are integral to a person yet shareable, become tangible when the physical setting is appropriated by people practicing them. As a global city, Tokyo attracts migrants with differing commonalities, who embed hybridized spatialities in the urban sphere as they share practices from their home-countries in their new locations.

The nature of the practices ranges from closed, such as religious, to completely open, like pop-cultural. Thus, mosques; South-Asian food and prayer facilities; and a Korean pop-cultural street were selected as case studies in Tokyo to demonstrate this gradient.

The aim of this thesis is to clarify the changes in identities, conflicts and adaptations that occur when spatial practices of migrant commonalities negotiate a new urban physical setting.

Appropriation of Tokyo through the Spatial Practices of Migrant Commonalities

Thesis abstract

List of Figures

List of Tables

1 Introduction

- 1.1 Literature Review of Relevant Concepts
- 1.2 Review of the literature on migration to Japan
- 1.3 Aim of the thesis
- 1.4 Objects of study
- 1.5 Methodology
- 1.6 Thesis organization and summary
- 1.7 Related research papers

2 Spatial Practices of Mosques in Tokyo

- 2.1 Introduction
- 2.2 Methodology
 - 2.2.1 The Behavioral and Architectural Norms of a Mosque
 - 2.2.2 Case studies of Tokyo Mosques
 - 2.2.3 Interviews of the Case Studies
- 2.3 Management of the Mosques
 - 2.3.1 Building
 - 2.3.2 People
 - 2.3.3 Activities
- 2.4 Adaptations of Mosques in Tokyo
 - 2.4.1 Analysis Example of Kamata Mosque (No.8)
 - 2.4.2 Adaptations of Architectural Norms within Mosques
 - 2.4.3 Miscellaneous Rooms
- 2.5 Adaptation Patterns of the Case Studies
 - 2.5.1 The Sequence of Architectural Norms within Mosques
 - 2.5.2 Architectural Expression and the Relationship between Mosque Management and the Adaptations of Norms
- 2.6 Conclusions

3 Spatial Practices of South-Asian Commonalities formed through Food and Prayer within Tokyo

3.1 Introduction

3.1.1 Previous Research

3.1.2 Objective of the Study

3.2 Methodology

3.2.1 Formation of Clusters

3.2.2 Field Survey of the Facilities

3.3 Spaces and Practice of South Asian Commonalities

3.3.1 Commonality of Food: Ethnic Grocery Shops and Restaurants

3.3.2 Commonality of Religion: Prayer Venues

3.4 Comparison between the Clusters

3.4.1 ShinOkubo and Kamata

3.4.2 NishiKasai and Jujo

3.4.3 Okachimachi and Ikebukuro

3.5 Conclusions

4 Content Spatial Practices Reinterpreting a Street into a Hanryu Shotengai

4.1 Introduction

4.2 Methodology

4.2.1 Parameters of Examined Content and the Physical Setting

4.2.2 The Threshold of the Setback

4.2.3 Content space and its Appropriation Elements

4.3 Encounter Zone - Content and the Physical Setting

4.3 Content Appropriation Elements in Encounter Patterns

4.3.1 Analysis Examples

4.3.2 Characteristics of Content space - Ikemen dori

4.4 Conclusions

5 Hybridized Spatialities

6 Conclusions

7 Appendix

List of Figures

- Fig 1.1 Thesis Organization Chart
- Fig 2.1 Behavioral and Architectural Norms of Mosques in Tokyo
- Fig 2.2 Example of Field Survey of Otsuka Mosque
- Fig 2.3 Analysis Example: Kamata Mosque (No.8)
- Fig 2.4 Kamata Kitchen (left, centre). Imam accommodation (right)
- Fig 2.5 Orientations of the Mosques in Tokyo according to the Qibla axis
- Fig 2.6 Adaptations of Architectural Norms
- Fig 2.7 Women's Jammah in Assalam Mosque using a TV monitor
- Fig 2.8 Domes of Tokyo Mosques
- Fig 2.9 Miscellaneous Rooms
- Fig 2.10 Patterns of Adaptation of Mosques in Tokyo
- Fig 3.1 History of the Influx of Migrants into Japan
- Fig 3.2 Increase in South Asian population in Tokyo
- Fig 3.3 Six clusters found in Tokyo
- Fig 3.4 Barahi grocery shop
- Fig 3.5 Sacred sculptures used in the Jain temple
- Fig 3.6 Swagat Bazaar, NishiKasai Cluster
- Fig 3.7 TMVS Foods, NishiKasai Cluster
- Fig 3.8 Tokyo Jain temple, Okachimachi cluster.
- Fig 3.9 Assalam mosque, Okachimachi cluster.
- Fig 3.10 A halal grocery store, Jujo cluster
- Fig 4.1 Korean Drama - Winter's Sonata, 2002
- Fig 4.2 Korean Drama -Crash Landing on You, 2020
- Fig 4.3 Ethnic facilities found in ShinOkubo area
- Fig 4.4a Domestic scale interior content space
- Fig 4.4b Extroverted content space
- Fig 4.5 Changes in Width - Ikemen dori, ShinOkubo
- Fig 4.6 Content Space - Ikemen dori
- Fig 4.7 Setback shapes - Ikemen dori
- Fig 4.8 Setback depth and width
- Fig 4.9 Connectivity of the Setback
- Fig 4.10 Overhead conditions of the Setback
- Fig 4.11 Examples of elements found in restaurants
- Fig 4.12 Examples of elements found in shops
- Fig 4.13 Encounter zone on the setback
- Fig 4.14 Encounter zone at Ikemen dori

Fig 4.15	Analysis Example - 33b Mr E1
Fig 4.16	Analysis Example - 7b Co E1E3
Fig 4.17	Analysis Example - 7a Rs E1E2E3
Fig 4.18	Analysis Example - 16 Rs E1E2E3
Fig 4.19	The Encounter zone completely hidden by elements
Fig 4.20	Contents replacing the facade
Fig 4.21	No 42a and 42b
Fig 4.22a	People eating in the street
Fig 4.22b	Browsing while still outside
Fig 4.23	People gathering in Ikemen dori
Fig 4.24	Magic shop, Ikemen dori - a catalyst for gathering
Fig 4.25	Woman watching Kpop videos while eating a cheesedog
Fig 4.26	Band photographers taking pictures of the group
Fig 4.26b	Band members handing out flyers
Fig 4.26c	Supporters forming a train behind the group
Fig 5.1	Principles of Appropriations
Fig 5.2	Assalam Mosque
Fig 5.3	ISKON Hindu Temple
Fig 5.4	Hindu Priest in front of Sacred Objects
Fig 5.5	Person watching K-pop idols
Fig 5.6	Chuo Sigean in Ikemen-dori
Fig 5.7	Sunshine Halal in Ikebukuro

List of Tables

Table 2.1	Location of Case Studies in Tokyo
Table 2.2	Interview Summary
Table 2.3	Pattern Analysis of Architectural Norms within Mosques
Table 3.1	The Spaces and Practices of South Asian Commonalities
Table 4.1	Contents found in Ikemen dori
Table 4.2	Appropriation Elements of Contents
Table 4.3	Encounter Patterns of the Appropriation Tendencies

1. Introduction

導入

Abstract

This chapter provides the theoretical framework with the relevant literature and a historical overview of migration to Japan. The methodology establishes the commonalities along a gradient in terms of accessibility; from closed, such as religious, to completely open, like pop-cultural. Interviews, field surveys and empirical observations were performed on the objects of study: mosques, South-Asian food and prayer facilities, and a Korean pop-cultural street, to demonstrate this gradient.

Migration is a continuous process that has been shaping cities throughout history. In the post industrial, globalized system, countries have drawn borders across maps and the issue of migration has been politicized as it accelerates. Yet, with the rise of global cities, like Tokyo, London and New York, the relevance of such borders has been overshadowed. Migrants, both local and domestic, flock to big cities to make their lives.

In Japan, the issue of migration has been sidestepped as the government applies stop-gap measures. Experiencing an aging society and a low birthrate in the face of a global pandemic, the need for people from other countries to work in Japan has been steadily increasing over the years. However, by sidestepping the issue of immigration, the Japanese government reinforces the myth of mono-ethnicity.

In spite of the noncommittal response, people from different parts of the world have been making their home in Japan. Tokyo, as the capital, receives the largest number of foreign workers. The movement of people is not just a movement of bodies in physical space, but also a palpable flow of practices, good, knowledge and ideas

about the use of space. As migrant people live their lives, their daily practices tie them to a location. By using the city for work, leisure, rituals and rest, migrants make places for themselves that align with the behaviours that they practiced in their origin country.

The city is affected by the daily practices at a granular level, which is then compounded as they are replicated in different urban locations over different periods of time. As different people share similar practices, values and ideas, commonalities emerge and are expressed in the urban sphere. In order to carry out their practices, migrant people must use the local resources. Resources include actual physical space but also cash funds, voluntary participation, real-life social networks, as well as social media, all of which contribute to the consolidation of commonalities.

This thesis focuses on how the concept of commonalities reconciles the factors of migrant practices with local material realm to embed hybridized spatialities in the city. In order to do so, the city of Tokyo was taken as a grand case study, in which the varying configurations of ideas, practices and physical settings render visible the different forms of commonalities extending throughout the city.

1.1 Literature review of relevant concepts

In order to examine the commonalities in the city and their associated spatial practices in the city, first definitions must be established for the discussion.

Definition of Spatial Practices

The definition of spatial practices used in this thesis is formulated by Henri LeFebvre. In order to avoid the binarism between the mental imagined space and the physicality of the built environment, LeFebvre introduces the third aspect of the lived realm of space, where users and their daily practices shape space and are shaped by space in turn.

The spatial triad proposed by LeFebvre comprises of (i) perceived space, or spatial practices, which is the daily routine of the users taking place in the physical setting; (ii) conceived space, representations of space, which is space drawn on paper by architects and planners; (iii) lived space, spaces of representation, which is the dimension directly experienced by the users.

“Spatial practice simultaneously defines: places - the relationship

of local to global; the representation of that relationship; actions and signs; the trivialized spaces of everyday life; and, in opposition to these last, spaces made special by symbolic means as desirable or undesirable, benevolent or malevolent, sanctioned or forbidden to particular groups (Lefebvre, 1991 p.288).”

In spatial practices, the material physical setting of the location is in direct contact with human beings and the relationships and networks that they develop. The primary way human beings interact with the city is with their daily routines, going to different destinations, using the street and buildings, engaging in both private and public life with connecting activities.

The city as a collector

The new layer of spatial practices that migrant commonalities introduce to the urban realm can be further understood through Peter Sloterdijk’s concept of the city as a “macrofoam”. According to Sloterdijk, societies are the “multiplicities of individual spatialities” in which humans can participate. Each individual spatiality refers to a spatial unit where humans are in proximity and develop strong reciprocal relationships. Sloterdijk terms this unit as a “bubble”, and describes cities as a macrofoam that is composed of such bubbles. Sloterdijk does not put a scale to the unit but each bubble is considered both autonomous as well as connected to its surrounding bubble. People, like bubbles, cannot live in a vacuum and reside in a society.

While Sloterdijk is concerned primarily with the atmospheric and meteorological dimension, this concept of a foam can also be applied in this thesis. Commonalities produced by the spatial practices of people coming from different regions can be considered not as something alien attaching itself to the local, but as one of the many bubbles that compose the dense foam of our cities.

Definition of Appropriation

Appropriation is commonly defined as taking [something] for one’s own use without permission. This thesis examines the appropriation taking place in the urban area by migrant population of Tokyo. In order to do so, the understanding of appropriation in the socio-cultural context must be reviewed.

“Appropriation” is usually discussed in terms of “cultural appropriation”. Cultural appropriation occurs when a majority group adopts

1. INTRODUCTION

cultural elements belonging to minority group in an exploitative and trivializing manner. Between majority and minority groups, there is always an imbalance of power. The majority group is usually more powerful and is able to take cultural elements from other groups without repercussion and without an understanding of the meaning behind them, causing a profound offense to the minority group.

Cultural appropriation causes harm in many ways. The identity of the minority group is attacked, especially if the appropriation by the majority group perpetuates reductive stereotypes, leading to marginalization and a loss of human rights. It also may cause the trivialization of the belief system of the minority group as their religious practices may be replicated while the meaning is discarded. The minority group may be economically harmed. For example, many indigenous people are unable to sell their traditional crafts as they are forced to compete with large companies that have appropriated and mass produce them.

Understanding that cities have a socio-cultural dimension, Henri Le Febvre discusses through his writings about the right of urban dwellers to put into practice their own notions of the use of space. The space of a city is dominated by the state and regulated by laws and policy. Henri LeFebvre through his writings critiqued this notion of the domination of the state over the practical life of the citizens. Le Febvre argues that the citizens residing in a city participate in activities such as dwelling, commuting, work and leisure. Thus, the citizens have an active role in producing relevant spaces, and therefore should have a say in the decision-making processes. Thus, the city is a resource for its inhabitants. LeFebvre explains that it is the collective right of the citizens to have the full use of space to respond to the varying demands of everyday practical life.

This thesis learns from the notions above to introduce a method of appropriation. Instead of being regarded as powerless people who must be assimilated into the “mainstream” culture, this thesis looks at how migrant people are able to reverse the narrative by being the agents who “appropriate” their urban physical surroundings, according to LeFebvre’s framework, operating within legal parameters and the hierarchical scales of power governing the city. The migrants, who form the minority group, have the agency to decide which factors of their culture they choose to share. Furthermore, the city is used as a resource by the migrant people to produce

spaces of this sharing, i.e., commonalities, for their own economic benefit and in service of their community members.

Appropriation in this study means a method of dwelling flexibly, mediating with the different scales of power, and adapting to the unique circumstances of urban reality that are found in the city of Tokyo.

Definitions of Commonalities

Commonalities are factors that are generated from common knowledge and practices, which communicate between human beings and transcend temporal and geographical boundaries. Atelier Bow Wow explains how architectural elements and behavioural practices are commonalities that manifest in the urban space¹. They describe how the repetition of similar buildings with slight variations form a typology and create a shared knowledge between inhabitants of the territory. This shared knowledge is often fixed to a certain place and time. With buildings and urban space, commonalities are made apparent through architectural elements, such as the roof and facade, and defy monopolization by the individual and belong to the common imagination.

Similar to the architectural elements that exist in common knowledge, behaviour can also belong to a group of people, yet is open for others to learn and join. The recursive behaviour connects people to the place and time, contributing to the accepted norms in that area. Thus, people with mutual differences can inhabit the same place as they engage in the similar behaviour with the shared architectural elements. The recursive behaviours are performed everyday, forming the spatial practices of the area.

In this thesis, the discussion on commonalities of behaviour and architecture is further expanded. In the post-industrial, globalized world, it is easier for commonalities to extend beyond geographical boundaries in which they were developed, transferred by the Internet technology as well as by the migration movement of people. Yet, cities have always been hosts to new forms of commonalities. In his article, 'Urbanism as a Way of Life' (1938), Louis Wirth² described the city as a place where commonalities between different people are shared.

"The city has thus historically been the melting-pot of races, peoples, and cultures, and a most favorable breeding-ground of new bi-

ological and cultural hybrids. It has not only tolerated but rewarded individual differences. It has brought together people from the ends of the earth because they are different and thus useful to one another, rather than because they are homogenous and like-minded.”

Cities are usually the main receivers of these heterogeneous commonalities as they attract large numbers of migrant populations. The diverse populations stack different layers of interactions and entities to the material form of the city, meaning spatiality. Sloterdijk calls the city a metacollector and discusses the notion of spatial multiplicities coexisting with each other. These multiplicities, which can be considered as numerous, differentiated “bubbles, compose a “macrofoam”. Each bubble is a place where human beings interact with each other and the material form of their surroundings to create a strong reciprocal relationship. Sloterdijk stresses how the macrofoam is not a flat layer but a “rhizome of interiors” extending out in all directions³. The spatial multiplicities can only exist when different groups of people possess commonalities with each other.

In examining the commonalities between migrants and non-migrants, Ayase Calgar and Nina Glick-Schiller are critical of the binarism of migrants and non-migrants. There must be a cognizance of the diversity of people, both migrant and non-migrant, living in Tokyo. According to Calgar and Glick-Schiller, it is especially important to refrain from seeing migrants with an “ethnic lens”, which leads to a simplistic binary of migrants and non-migrants. Calgar and Glick-Schiller describe how the portrayal of migrants living in cities has a tendency to oversimplify the agency of migrants to produce space. The binary drawn between the local and the migrant draws an unconscious boundary around the latter, forming them into a homogeneous entity with identical values, experiences and aspirations. Instead, there is a diversity in the relationships non-native residents have with their place of settlement, their place of origin and the networks that are created in their sojourn. This binary leaves no room for commonalities of shared interests, activities and values between migrants and nonmigrant people to occur. Calgar and Glick-Schiller suggest the removal of such a binary and emphasize the forging of domains of commonality between local and migrant. They analyze how migrants through actions such as starting entrepreneurial activities or establishing religious spaces contribute to the nexus of networks that constitute the city. Migrants are social agents who form an integral part of

the city as they engage in their daily spatial practices. They forge new networks and relationships with local nonmigrants to participate in developing commonalities. There are domains of commonalities, i.e. shared interests and common values, between migrant and “non-migrant people” as there are gradients of differences in experiences, aspirations, education and background between migrant people.

1.2 Review of literature on Migration to Japan Current Situation of Migration in Japan

The spread of COVID has affected the movement of people in an unprecedented way, the results of which are that to be seen. Prior to the global pandemic, the Japanese government’s approach in allowing foreign nationals to live and work in the country has been regarded as difficult to understand and subject to variance without a comprehensive plan. In 2016 and 2019, there were changes in the 1945 Cabinet Order No. 319 Immigration Control and Refugee Recognition Act to facilitate immigrants with special skills that would help the increasingly aging Japanese society, such as care, nursing and technical agricultural fields. In 2021, an amendment proposed by the Japanese government to the Immigration Act was criticized as detrimental to the rights of refugees and displaced persons and was abandoned. With the issues of a low birthrate and an ageing society, the Japanese government sees the advantages in facilitating people coming from different countries, yet has been unable to come up with a definite plan with regards to immigration, unlike Western countries such as the United States or Germany.

Historical Background

Japan, in its past, has been in self-placed quarantine from the foreign movements, an occupying force in other countries and an occupied country as well. These factors have subsequently influenced Japan’s relationship with foreign incomers today.

After the Opening of Japan, there was a movement of people from China and India to live and work in Japan. Chinese workers specialized in professions which used knives and razors, as well as labourers and longshoremen entered Japan until the 1920s. Also, Indian traders and merchants took the opportunity to extend their trade networks from China into Japan.

However, Japan entered a militant colonizing phase soon after. Japan occupied the Taiwanese islands in 1895 and annexed Korea in

1. INTRODUCTION

1910, Manchuria in 1931. The movements of people were obviously affected by war. The residents of these lands were not Japanese but were now living on Japanese territory and yet denied equal rights that were given to Japanese citizens. As colonization deprives the local people of their rights and livelihoods, there was a subsequent movement of people from the occupied lands of Taiwan and Korea to Japan. Yet, the Manchurian incident triggered a return of Chinese people.

The Zainichi Koreans are probably the most famous migrant population who reside in Japan. Their beginnings are much discussed by scholars who study migration and Japan. They were not a uniform group, but comprised of labourers, professionals, entrepreneurs and students

The Second World War ended with the independence of many countries, such as Pakistan and India from the British and the Koreans from Japan, but then Japan came under Allied Occupation. 1.5 million Koreans returned but 500,000 - 600,000 stayed in Japan. Indian traders were cut off but continued to live in Japan.

Japan's defeat and occupation by Allied Forces spelled disaster for the multiethnic society that was still beginning. The idea of a homogeneous nation gained traction and foreigners were seen as agents to be controlled, which continues to colour the stance on immigration to this day. In the year of Japanese independence of 1952, Korean and Taiwanese subjects living in Japan were stripped of their citizenship and associated rights. However, zainichi Chinese and Korean people alongside activist groups and local governments campaigned for the same rights as Japanese nationals and prevailed upon the central government to grant rights such as access to healthcare and the national pension system. Though there was no directive from the central Japanese government, local authorities often granted the same rights as the native residents.

Unlike Western countries, the real influx of foreign migrants to Japan well into the 1970s. John Lie describes in his book that after Japan's defeat in World War II, 6.6 million Japanese were repatriated to the main islands. Such a mass influx of Japanese citizens from the four corners of the empire and the constant labor surplus galvanized the Japan Emigration Agency to "stimulate emigration through various measures such as posters and propaganda films, [and take] extensive measures to help emigrants with technical

and financial assistance to support successful settlement abroad” (Mori 1997:35; cf. Suzuki J. 1992:257–261). According to Fujisaki, says John Lie, the last ship to carry Japanese emigrants to Brazil departed Japan in 1973 (Fujisaki 1991:54).

Lie goes on to describe postwar Japan to experience the most rapid rural exodus in the history of the world, as four million farmers became urban workers annually in the late 1960s (Mori 1997:55–57). Women’s labor force participation was equally remarkable as from the early phases of industrialization, Japanese women worked in a variety of jobs, and their presence in the labor force was higher than that of their European counterparts until the 1970s (Koike 1981:248–249).

As the Japanese economy continued its rapid growth in the 1960s, the labor-surplus economy was transformed into a full-employment economy. Rural migrants, seasonal workers, women, part time students and older workers joined the labor force (Koike 1981:189–192). In response the time's labor demands, there were efforts in the late 1960s to recruit workers from South Korea and elsewhere

According to Komai, the demand for foreign labour increased in the 1970s and had four patterns of incoming foreigners: (a) entertainment industry workers, (b) Indochinese refugees from Vietnam, Cambodia and Laos, (c) descendents from Japanese colony in China, who came with their spouses and children, (d) business people from European and North American countries. The increase in the highly differentiated foreign community continued to increase until the latter half of the 1980s. There was an increase in visa overstayers who started to work in Japan in the low paying, low skill type of jobs. There was also a big movement of Nikkeijin, descendents of Japanese nationals from Latin America. The Immigration Control Act of 1989 facilitated the relocation of Nikkeijin and their families to live and work in Japan. This triggered an enormous movement from Latin America, mainly Brazil, to Japan.

In the 1990s, Japan entered a period of stagnation but the movement of people from different countries lessened but did not stop. The “old-comers”, people of Chinese and Korean background that had lived in Japanese colonies and their descendants were outnumbered by “new-comers”. The Chinese population in Japan was by far the largest, and was extremely diverse, consisting of spouses or children of Japanese nationals, university students, profession-

als and trainees, jobseekers and also visa overstayers. The second largest group, that of Brazilian Nikkeijin, was relatively more homogenous than the Chinese group. The third largest group was that of Koreans, newcomers who are considered different from the zainichi Koreans who lived in Japan directly after the war.

Definition of migrant

In the previous section, an overview of migration to Japan was covered. As Chung discussed in her work, immigration to Japan is not an easy task, compared to Western countries such as the United States etc. The Japanese government deflects the issue by applying stop-gap measures according to the labour requirements of the moment.

An example of this is the recent immigration law that permits indefinite stay of foreign workers who are related to the care-giving and agricultural fields.

Keeping this situation in mind, this thesis proceeds to analyze the practices of commonalities that originated outside of Japan, yet have taken root in the non-native soil. The people who took part in these practices were diverse and included:

- Students and contract workers with a defined length of stay
- People with work contracts that were repeatedly renewed, leading to an indefinite length of stay.
- Entrepreneurs that had opened business in Tokyo but did not rule out a return to their origin country.
- People who married local Japanese people and became permanent residents.
- People of the zainichi Korean community who were born and raised in Japan but were not “ethnically” Japanese.
- Refugees and asylum seekers.

Japan has a “jus sanguinis” policy regarding citizenship, which meant that even children who were born in the country had the “foreigner” status attached to them. This thesis is highlighting the agency that non-local people have during their stay in the country of their choosing. In order to remain sensitive to such a diverse range of backgrounds, the terminology used had to be approached cautiously. The main commonality between the people, of course, can be rather simplistically described as “not Japanese”. Therefore, the terms “immigrant” and “migrant” were reduced to their most basic definitions:

Immigrant (Noun) :

Crosses an international border. Permanent stay in host country.

Migrant (Noun / Adjective):

Moves from one region to the other, can be domestic or international. Undefined period of stay.

The term “immigrant” becomes immediately unsuitable as it cannot be used to describe the short-term sojourners, zainichi Korean community or even local Japanese people take part in the practices of the “foreign” commonalities, such as converting to Islam or Hinduism.

The term “migrant” on the other hand does not limit the discussion to only international movement. It communicates movement of varying qualities, such as domestic vs. international, temporary vs permanent, decided vs. undecided, inherited vs. uninherited.

1.3 AIM OF THE THESIS

While it is generally accepted that Japan is monoethnic, Tokyo is home to people with different ethnicities, genders, educational and socioeconomic backgrounds. Even in the post-pandemic world, networks stretch out beyond the geographical territories of cities and countries to connect the individual level to the transnational levels. Migrants are a crucial vector in these transnational levels, as when they sojourn from one point on the globe to another, they bring their own knowledge and networks to apply to their new surroundings. In such applications, new spatialities are forged. When entering the new surroundings, migrants experience both absences and opportunities, and they may use their networks from their home country and/or the relationships they have newly established to produce new places of work, rest, or leisure to participate in daily life. These actions, which are tied to a location in the city, are termed as spatial practices, and have a tangible effect on the urban character of the locality. Such spatial practices and the resultant changes they induce embeds a new layer of identity in the nexus of the city.

This thesis aims to clarify the changes in identities, conflicts and adaptations that take place when spatial practices of migrant com-

monalities negotiate with the existing socio-spatial setting of the city.

1.4 OBJECTS OF STUDY:

Throughout this thesis, there has been a concentration on the fine-grain of the city, as it is at this level that people can change their surroundings with their own power. One of the challenges was to identify which commonalities to study and why. They had to be brought from other countries to Japan as well as being clearly visible in the city to evaluate how they participate in the urban surroundings through their behaviours and architectural elements.

Following this logic, the commonalities of religion, food and pop culture were investigated.

(i) Commonality of religion - Mosques

The commonality of religion was examined by analyzing the spatial practices of mosques in Tokyo. The basic function of the mosque is to provide a communal space for prayer for the religion of Islam. Yet, depending on the community that initiated the mosque, the process of establishment and the adaptations that take place to optimally practice the religious rituals in the new have a high degree of variation. This section goes deeper into understanding how buildings are selected, what obstacles are faced and which factors are influential when renovating an existing building into a mosque or constructing a new one.

(ii) Commonality of food - Grocery shops and restaurants

Food from different regions of the world is easiest to access within a city. It is the first point of introduction between cultures and easily shareable and replicated. However, food has a different level of meaning for migrants as they sojourn in their new locations.

The facilities of South Asian ethnic grocery shops and restaurants were studied to examine the commonality of food, while South Asian initiated prayer venues were studied for the commonality of religion. Grocery shops are a source for migrant populations to replicate traditional cooking and other domestic processes within the home. They become a visual marker of a minority ethnicity residing in the area. Restaurants provide the cuisine of a specific country or a fusion of a particular region but also apply the religious dietary restrictions that people belonging to a similar background may have, making it accessible to the minority ethnic group but also to the

majority population. Food is deeply intertwined with religion for many migrants. A spiritual and physical link to the home country is preserved by the continuing the practices associated with food and prayer in the new location. Thus, the association of food with prayer venues was also examined.

(iii) Commonality of pop-culture - Restaurants and content shops
The form of commonalities is of those which actively reach out for new members. The phenomenon of “Hanryu” and how it is exhibited in the urban sphere is examined. The commonality of Korean pop-culture expands over differences in age, gender and ethnic background, yet its appeal is firmly tied to its roots. Shinjuku, which is one of the main areas in Tokyo where people of different migrant identities established themselves, is a place of both contestation and of emplacement and was selected to clarify the urban local context. One street, known as Ikemen Street, exemplifies this phenomenon.

1.5 METHODOLOGY

This thesis provides a critical approach to understanding how migrant commonalities are performed and their material realization in the city by adopting a methodology focused on case studies found in the urban sphere. The method builds further upon the concept of commonalities by adding the notion of a gradient. Ignoring the spatial practices of migrant commonalities runs the risk of ignoring the new characteristics of urban space that a global city such as Tokyo encompasses. Thus, the theoretical framework expands the discussion by diversifying the types of commonalities and the people who participate in them to develop the spatial practices in the context of Tokyo.

The methodology is rooted in the theory of commonalities developed by Atelier Bow Wow and uses it in conjunction with other theories of spatiality in architecture. The theoretical framework was developed using real life case studies to ensure that the relationship of the spatial practices of the commonalities with the physical setting was substantially questioned and clarified. The notion that a gradient of membership is present in the different types of existing commonalities is established to further understand the relationships people, coming from different regions of the globe, develop when their embedded recursive behaviour physically manifests to produce their own spaces in the local urban material sphere using their new surroundings.

The notion of the gradient of memberships is demonstrated by situating it in different models in order to present a holistic understanding of the concepts involved. The methodology is applied in the following three chapters. First, the closed commonality of religion is understood by examining the application of architectural and behavioural norms of Islamic mosques which have been developed in one context to a new one that of Tokyo. Then, the commonalities that are rooted in tradition, food and prayer facilities, are examined, which have both a semi-open and closed nature by taking an overview of the new layer of commonalities they embed in Tokyo and comparing their clusters to one another. Finally, the fully open commonality of Korean pop-culture, which endeavours to expand by using its migrant aspect as a device, and its effect establishing an identity of an area is examined.

1.6 THESIS ORGANIZATION AND SUMMARY

This thesis is divided into six chapters. The first chapter, "Introduction", establishes the basic definitions that will be used in the study by reviewing the relevant literature. The background of migration to Japan is also covered to give context to the discussion of commonalities coming from different regions into Japan. The main aims were established, then the objects of study were determined and finally the methodology was discussed.

In chapter two, "Spatial Practices of Mosques in Tokyo", the effect of behaviour on architectural elements and the physical surroundings was examined. The typical mosque typology was deconstructed and then divided into architectural elements, terms as "Architectural Norms", and their associated "Behavioural Norms." The behavioural norms of: Adhan; Wudu; Khutbah; Iqamah; and Salat were determined. Each behavioural norm was associated with an architectural norm. Adhan with Minaret; Wudu with the Wudu area; Khutbah with Minbar and Salat area; Iqamah with Salat area and Salat with Salat area. Field surveys of the eleven mosques in Tokyo were carried out and interviews were held to determine the management of the mosques. Management included an overview of the Building, People and the Activities they carried out. The sequence of the mosques was deconstructed and then the practices of each of the behavioural norms alongside their architectural norms was discussed. Each architectural norm underwent different adaptations to facilitate the performance of the religious behaviour in the new surroundings. This process clarified the conflicts that

arise when transferring practices from one region to a new location and what adaptations have to take place. The non-compromisable aspects of the behavioural and architectural norms as well as those which had to be removed were explained. The critical aspects of the Salat and Wudu areas were explained and were used to divide the case studies into seven patterns. Lastly, the relationship between the architectural expression, mosque management and the architectural adaptations of the norms was discussed.

In chapter three, “Spatial Practices of South Asian Commonalities formed through Food and Prayer within Tokyo”, the discussion of commonalities was applied to the real world urban level in Tokyo. Previous literature research on South Asian communities in Japan was examined and a lacuna was established regarding the interrelation of South Asian populations and the spaces they create for and by themselves in the city. Grocery shops provided a valuable service both to the migrants who are first coming to their new place of residence, but also to the local majority by introducing them to different ingredients. People may have dietary restrictions due to religion or simply wish to recreate recipes that they know, find such places as essential during their sojourn. Restaurants also play an important role as they are a gateway between different cultures. They provide migrants living in the city as a place to access ready-made food that is according to their culture or religion, but are also places where the local majority can develop an appreciation for different cuisines. It was determined how the agglomeration of the facilities of grocery shops, restaurants and prayer venues, termed as clusters, had an effect on an urban level by embedding another level of South Asian identity to the local area due to their spatial practices, and were commonly associated with a particular train station. Six such clusters were identified. It was seen that grocery shops and restaurants, through the commonality of food, created a gradient of identities related to ethnicity. The prayer venues researched in this paper were established by South Asian communities to reach out to their own community as well as other ethnic backgrounds. The clusters were then compared to one another to clarify the character and development over time.

In chapter four, “Content Spatial Practices of a Reimagined Hanryu Shotengai”, the facilities of Korean restaurants; skincare and clothing shops were of special interest, as they encompass the Hanryu phenomenon within the urban realm and attract the local people of all backgrounds. One street, colloquially known as Ikemen street

1. INTRODUCTION

was the subject of study due to the high concentration of related facilities. The contents of the facilities do not remain within the interior space but spill into the setback. The setback became of prime importance due to the narrowness of the street, and is the point of encounter and of appropriation. The physical space between the facade of the building and the curb of street was dissected to clarify the layers of behaviour, imagination and the physical setting of the city. The terminology to describe content space was developed in this study to describe extroverted content space formed by the collective consumption of Korean pop-culture.

In chapter five, the findings from each chapter are extracted and are discussed to position process migrant commonalities undergo as they negotiate with the urban situation in which they exist. Chapter six summarizes the chapters and their concluding points.

1. INTRODUCTION

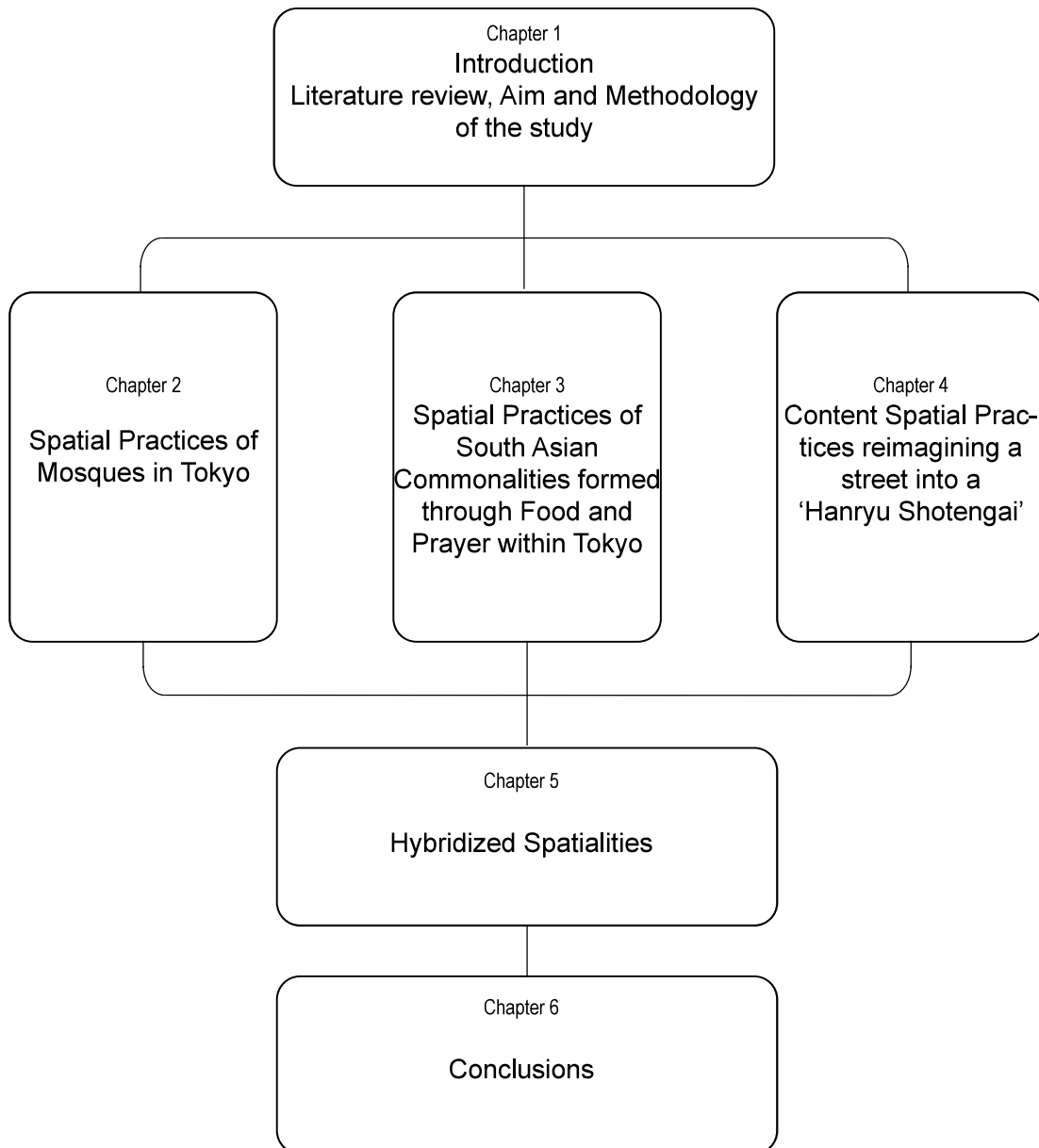

Fig. 1.1 Thesis Organization Chart

1.7 Related Research Papers

* Rahman, Amena; Sasaki, Kei; Tsukamoto, Yoshiharu.
“Spatial Practices of South Asian Commonalities formed through
Food and Prayer within Tokyo”
published in AIJ Journal of Technology and Design Issue 67 (October 2021)

** Rahman, Amena; Iwana, Davina; Sasaki, Kei; Tsukamoto,
Yoshiharu.
“Spatial Practices of Mosques in Tokyo”
published in AIJ Planning and Papers Vol 86, No. 789 (November 2021)

References

1. Kooperatives Labor Studierender + Atelier Bow-Wow: Urban Forest. Spector Books. 2016
2. Wirth, L.: 'Urbanism as a Way of Life', American Journal of Sociology Vol. 44, Chicago 1938
3. Sloterdijk, P: Spheres.3:Foams: plural spherology. Semiotext(e). 2016
4. Lefebvre H.: The Production of Space, translated by Donald Nicholson-Smith, Blackwell Publishers, 1991
5. Certeau, M: The Practice of Everyday Life. University of California Press, 1984
6. Lie, J: Multiethnic Japan. Harvard University Press 2001
7. Çağlar, A and Glick-Schiller, N.: Migrants and City-Making: Dispossession, Displacement, and Urban Regeneration“. Duke University Press. Durham and London. 2018
8. Kinoshita Y: “Japan Needs to Reform its “Black Box” Approach to Immigration Law” <https://www.nippon.com/en/in-depth/d00710/> . June 23, 2021
9. 留学生が急増、10倍に 日本で「手に技術」 <https://mainichi.jp/english/articles/20161105/p2a/00m/0na/004000c> . November 5, 2016
10. Menju, T: Japan's Historic Immigration Reform: A Work in Progress. <https://www.nippon.com/en/in-depth/a06004/japan%E2%80%99s-historic-immigration-reform-a-work-in-progress.html> Feb 6, 2019
11. <https://elaws.e-gov.go.jp/document?lawid=326CO0000000319>
12. <https://www.loc.gov/item/global-legal-monitor/2016-12-27japan-foreign-care-givers-will-soon-be-able-to-work-in-japan/>
13. Suzuki, E; Scant Hope for Japan's “Illegals” Under Proposed Reforms. <https://www.nippon.com/en/in-depth/d00705/> May 20, 2021
14. Nagano Takeshi: Zainichi Chugokujin: rekishi to aidentiti. Tokyo: AkashiShoten. 1994. [In Japanese]
15. Chung E: Immigration and Citizenship. Cambridge University Press 2010
16. Castles, S. and Miller, M.J. The Age of Migration: international population movements in the modern world, Hampshire and London: Macmillan. 1993

2. SPATIAL PRACTICES OF MOSQUES IN TOKYO

東京におけるモスクの空間的实践

Abstract

Muslims living in Tokyo have built mosques to continue their religious practices that have essential and unchanging religious behavioral norms, related to the architectural norms of the Minaret, Wudu, Salat, Mihrab, Minbar. Conflicts arise when the architectural norms encounter the existing physical setting of the city and they must be adapted to ensure that the behavioral norms can be practiced. This chapter investigates the mosques in Tokyo and, through interviews and field surveys, extracts patterns of adaptations of the architectural norms and makes apparent the diverse practices of the mosque for the establishment of Muslim identities.

2. SPATIAL PRACTICES OF MOSQUES IN TOKYO

2.1. Introduction

In a Muslim-majority country, the mosque is one of the significant urban facilities spread through the neighbourhoods. Mosques refer to the architectural heritage of each country, as well as the common elements found in Islamic architecture. As Japan is not Muslim-majority country, the number of mosques is quite small, though there has been an increase over the past years. In Tokyo, some mosques are newly built as religious facilities while others are renovated buildings. These religious facilities take on the additional roles of being places for education, business and social exchange and have variations resulting from the limitations they face in the physical urban condition of Tokyo. However, these limitations have produced creative ways to practice religious rituals by negotiating with the existing physical setting.

This study creates a framework where the typical mosque of a Muslim majority country is deconstructed into behavioral norms and their associated architectural norms. Through this deconstruction, the key sequence that must be maintained by the facility in order

2. SPATIAL PRACTICES OF MOSQUES IN TOKYO

Norm		Description	Prayer Mat (mm)
Behavioral	Architectural		
Adhan	Minaret	The call to prayer, typically given from the Minaret	
Wudu	Wudu area	Ablution with water	
Khutbah	Minbar Salat area	The Friday oration of the Imam, given while using the Minbar	
Iqamah	Salat area	Second call to prayer within the mosque	
Salat	Minbar Salat Area	The ritual prayer. The Imam stands in front of the Mihrab. The Jamaah assemble in rows behind him and pray facing the direction of Makkah	

Fig 2.1 Behavioral and Architectural Norms of Mosques in Tokyo

Table 2.1 Location of Case Studies in Tokyo

Map	No	Mosque		Location	Building	
		Name	F.Yr		Year	Condition
	1	Dar al Arqam	2000	Asakusa	1995	Renovated -Ov
	2	Tokyo Camii	1938	Yoyogi Uehara	2000	New
	3	Otsuka	1999	Otsuka	2000	Renovated -Ov
	4	Al Tauheed	2002	Hachioji	2002	New
	5	Hiroo (AI)	1982	Hiroo	2000	New -Pa
	6	Makki	1995	Ohanachaya	2001	Renovated -Ov
	7	Assalam	2010	Okachimachi	2010	Renovated -Ov
	8	Kamata	2013	Kamata	2014	Renovated -Ov
	9	Al Ikhlas	2016	Kabukicho	2016	Renovated -Ov
	10	Indonesia	1962	Meguro	2017	New
	11	Nusantara	2019	Akihabara	2019	Renovated -Pa

F.Yr - Founding Year

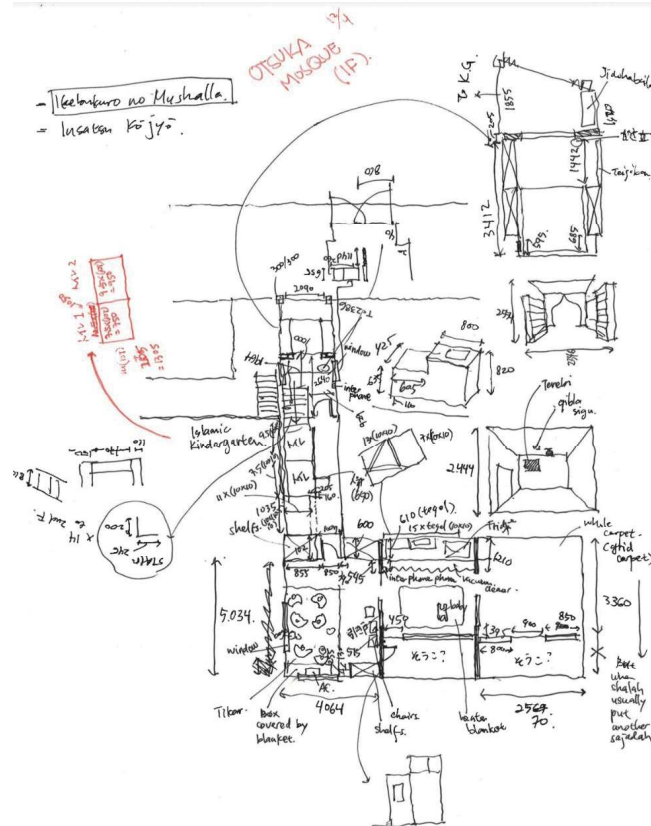

Fig 2.2 Example of Field Survey of Otsuka Mosque

2. SPATIAL PRACTICES OF MOSQUES IN TOKYO

to be used as a mosque in Tokyo is highlighted. The spatial practices of this sequence involve the necessary modifications of interior spaces as well as the symbolic adaptations to the exterior. This study aims to analyze mosques in Tokyo to illustrate how architectural norms may be modified through the encounter between Tokyo conditions and religious behavioral norms.

Muslims are a part of the people coming to Japan from different countries who bring with them their own methods of worship¹⁾. Tanada Hirofumi provides a broad overview of the Muslim population residing in Japan and their communal efforts to construct mosques through the utilization of their migrant network and the self-mobilization of their financial resources. In addition, Tanada also looks at the role the mosque plays in the lives of this community²⁾. Also on the broader scale, Tanada Hirofumi and Okai Hirofumi chart a historical record of mosques built at a country-wide scale in Japan and analyze the network between them. They critically analyse the relation of the growing community of Muslims with the local Japanese population³⁾. Okai looks at the religious solidarity and mobilization of financial capital from within the migrant networks that lead to the establishment of mosques⁴⁾. Narrowing the focus to Tokyo, there is information on the development of non-permanent religious spaces of Muslims, called musallahs, into permanent mosques, and the social functions they perform⁵⁾ and the daily obstacles that must be overcome⁶⁾.

However, there is not much research from the viewpoint of the adaptations of architectural norms and their spatial relationships from typical mosques of Muslim countries into mosques in Tokyo. This research looks to the Lefebvrian concepts of spatial practices⁷⁾ to analyze how sacralization through ritual behavior materially and ideologically produces distinctive religious spaces⁸⁾. According to Lefebvre, spatial practices are those actions that take place within the lived space and give it structure. The collective practice gives the space meaning. As will be discussed in this study, the mosques in Tokyo vary highly in building typology, people and organization. However, by looking through the lens of spatial practices, we can analyze all the cases in this study within a single framework.

2.2 Methodology

In the methodology, the typical mosque in a Muslim country is deconstructed to understand the sequence of behavioral norms and their associated architectural norms (Fig.1).

2.2.1 The Behavioral and Architectural Norms of a Mosque

The purpose of the mosque is to provide a congregation space to perform the ritual of prayer called Salat in a communal way. A sequence of “behavioral norms” is followed: Adhan – the call to prayers, a vocal announcement that alerts the neighbourhood that the time for a specific prayer has begun; Wudu – an ablution performed prior to prayer; Iqamah – the second call to prayer within the mosque that signals the immediate beginning of Salat. Salat - the actual ritual of prayer that must be performed facing Makkah. The leader of the prayer is called the Imam. The rows of the congregation stand behind the Imam, collectively called the Jamaah, while facing Makkah. In addition, a sermon called the Khutbah is given each Friday, the day of congregation in Islam.

The behavioral norms are associated with “architectural norms” (Fig.1). The behavioral norm of Adhan is given at the architectural norm of the Minaret, a typical element of Islamic architecture. The behavioral norm of Wudu is performed in the architectural norm of the Wudu area. The behavioral norm of Salat is given in the main prayer area, termed as the Salat area, but can also performed in any space of the mosque. During Salat, the Imam and Jamaah face the Mihrab, which is a niche in the wall in the direction of the Makkah. The Iqamah and Khutbah have the interior architectural element of the Minbar, a small, low platform that raises the Imam so that they congregation may see and hear him clearly.⁹⁾

It is these fundamental architectural norms that need to be adapted in order to create a mosque in Tokyo. Furthermore, it is necessary to study the Minaret, Salat and Wudu areas in relation with each other, as only when taken together do they have a religious implication. For example, the Minaret in isolation is just a tower. Only when it is attached to the Salat area and the Wudu area does it become significant⁹⁾.

2. SPATIAL PRACTICES OF MOSQUES IN TOKYO

Scope of study

Establishing a mosque in Tokyo is an organic process. Oftentimes, the size of the mosque cannot be pre-determined and it takes many years as a Muslim community coalesces. Usually spaces are rented to create communal prayer venues known as “musallahs”¹⁰⁾. Musallahs are temporary and are not considered as permanent prayer venues that are congregational mosques. For example, in the case of Otsuka mosque, the initiators first rented spaces near the Ikebukuro station. As the number of Muslim residents in the local area increased, and the rented mosallah attracted Muslims living in other vicinities, the initiators were able to gather enough funds to establish a permanent mosque at Otsuka. This research focuses on the existing eleven congregational mosques*¹ in Tokyo (Table 1). and does not include “musallahs”.

In this chapter, the physical space in which the Salat is practiced will be referred to as the Salat area and the space for practicing Wudu will be called the Wudu area.

2.2.2 Case studies of Tokyo Mosques

Ten out of the eleven case studies are owned buildings except for Nusantara (No.11), which is a rented space. In Table 1, the Founding Year refers to when the mosque was founded. Building Year refers to the year the current building started to be used as a mosque, according to the interviews that were conducted. They are divided into two types: New Building and Renovated Building (Table 1). Four mosques (No. 2, No.4, No.5, No.10) have been purpose-built as mosques with new buildings [N], with Hiroo mosque (No.5) categorized as New-Pa as it was designed as part of the cultural complex of the Arab Institute building. The remaining seven are Renovated Buildings, having adapted existing built structures. The buildings are further subdivided into Overall [Ov] as they have been completely renovated according to the requirements of the mosque (No.1, No.3, No.6, No.7, No.8, No.9, No.11); and Partial [Pa] Nusantara (No.11) is categorized as Renovated -Pa as it uses only the fifth floor of an office building. The other floors of this building are unrelated to the Nusantara mosque. The physical space of each of the mosques was measured and the articulation within the building was recorded (Fig. 2).

2. SPATIAL PRACTICES OF MOSQUES IN TOKYO

Table 2.2 Interview Summary

Mosque	1. Dar Al Arqam	2. Tokyo Camii	3. Otsuka	4. Al Tauheed	5. Hiroo-Arab Institute	6. Makki	7. Assalam	8. Kamata	9. Al Ikhlas	10. Indonesia	11. Nusantara		
BUILDING	Previous Use	Office Building	New Building	Office for printing company	New Building	New Building	Office for electronics manufacturer	Residential apartment building	Residential apartment building with laundromat	Residential apartment building and izakaya	New Building	Office for construction company	
	Building / Plot Selection	Selected by Islamic Center of Japan	Plot owned by Turkish Government	Selected by community	Plot donated by Saudi Arabian businessowner	The Institute was donated by the Saudi Arabian govt.	Selected by community	Selected by Islamic Center of Japan	Asked local people and found through a developer	Owned by Indonesian community member	Built beside the Indonesian School	Owned by friend of the chairperson of Al Ikhlas	
	Interior Layout	Layout by Islamic Center of Japan	Construction company employed by mosque organization	Layout by Islamic Center of Japan	Layout by mosque organization	Designed as part of the Institute	Decided by community suggestions	Decided by chairperson with Islamic Center of Japan	Decided by community suggestions	Decided by owner and Indonesian trainees	Indonesian architect who studied with local architect	Decided by community suggestions	
	Building Method	DIY work by community members	Japanese contractors with Turkish craftsmen	Japanese contractor	Japanese contractor	Japanese contractor	DIY work by community members	Japanese contractor	Carpenter hired by community donations	Indonesian carpentry trainees	Japanese contractor	Indonesian carpentry trainees	
PEOPLE	Mosque Funding	CE	GB	CE	CE	GB	CC	CE	CC	CE	CE	CE	
	Administration	Organization - Islamic Center of Japan	Turkish govt. organization Directorate of Religious Affairs	7 person committee registered as an organization	2 Imams and 1 administrative employee	The Arab Institute's organization	Organization known as Tablighi Jamaat *	Chairperson, Imam and administrative assistant	Committee registered as a corporation	Committee of Indonesian members	Organization known as KMII **	Committee of Indonesian members	
	Imam	1 Imam, accommodated in the mosque	2 Imams. 1 for religious activities, 1 for management	No fixed Imam	2 Imams. Live with family, accommodated in mosque	3 Imams from the staff of the organization. Live nearby	2 Imams invited from outside Japan	Guest Imam from different countries	Imam employed by the mosque. Lives with family nearby	1 Imam is from AlIkhlas, 1 Imam from Nusantara mosque	4 -5 Imam. Teachers and student volunteer	Same Imam from Al Ikhlas mosque	
	Visitors	Families, students, workers, tourists	Families, students workers, tourists	Families, mothers with children, single workers	Families, Students from different countries	Staff, people working in the vicinity, passerbys	Male office workers, self-employed, students.	Multiethnic regular attendees, tourists	Single workers from different countries	Indonesian students, trainees, workers	Residents, school employees, trainees	Indonesian students, trainees, workers	
ACTIVITIES	Communal Meal Preparation	Cooked by volunteers, order from restaurants	Turkish chef. Free lunch on Friday by volunteer cooks	Volunteers and donations by Muslim restaurant	Donated Friday lunch from Egyptian restaurant owner	Institute staff chef, order bread from local bakery	Cooked by volunteers from community	Employed chef using the mosque kitchen	From restaurant. Volunteers prepare in Ramadan	Prepared by Al Ikhlas chairperson	Volunteers or have catering	Al Ikhlas chairperson and volunteers	
	Ramadan	Meals at sunset and sunrise. Night prayers	Sunset meal and night prayers. Lectures	Sunset meal and night prayers. Sermons by guest lecturers	Sunset meal prepared by Imam and volunteers	Night prayers Lectures	Sunset and sunrise meals in Ramadan. Daily prayers	Sunset meals. Night prayers. Lecturers from other countries	Meals at sunset and sunrise. Night prayers	Invite Imam and scholars from Indonesia	Meals at sunset and sunrise. Night prayers. Lectures	Meals at sunset and sunrise. Night prayers	
	Jamaah Capacity	Friday Eid	130 6000	100 700	200 300	150 300	500 1500	200 300	500 1000	200 600	40 —	200 500	100 400
	Eid	Multiple Prayers	○	○	○	○	○	—	○	○	—	○	○
		Communal Meal	○	—	○	—	○	○	○	○	—	○	○
		Other rooms for Salat	○	○	○	○	○	○	○	○	○	○	○

*) Tablighi Jamaat is an international Islamic Missionary Movement **) Keluarga Masyarakat Islam Indonesia (KMII) is an Indonesian Islamic missionary organization

2.2.3 Interviews of the Case Studies

The interviews were held in the later half of 2018 with the administration, the Imams as well as visitors to each of the case studies. The interviews uncovered the integral role it plays in the visitors' lives.

2.3. Management of the Mosques

The information compiled from the interviews is structured into sections of Building, People and Activities (Table 2). The section of Building shows the degrees of involvement of the local Muslim community and the different approaches taken in establishing a

2. SPATIAL PRACTICES OF MOSQUES IN TOKYO

mosque. People are the driving force in each of the mosques and this section looks at who administrate and visit the mosque in order to keep it alive. The section of Activities shows how the mosque is sustained through the activities of the people who visit it.

2.3.1 Building

The selection of the plot or building are quite varied and depends on the resources available to the users of the mosque. For example, Al Tauheed (No.4) had its plot donated by a businessman while Kamata mosque's (No.8) building was purchased through community donations. In contrast, Tokyo Camii (No.2) and Hiroo (No.5) are owned by government organizations. The interior layout of the Wudu area and the Salat area, direction of Makkah etc. are considered by the people who are using the mosques. Four of the eleven mosques' plots (No.6, No.8, No.9, No.11) and their interior layouts have been decided by community suggestions, reflecting participation in being a part of the origin of the mosque as well as taking part in its activities. Three mosques are purpose-built by international organizations: Tokyo Camii (No.2), the Indonesia mosque (No.10) and Hiroo (No.5). Three mosques (No.1, No.3, No.7) consulted with a national organization, the Islamic Centre of Japan, for building or interior layout. Al Tauheed (No.4) used its own organization. Participation is also reflected in the building method of the mosque as well. Four of the mosques (No.1, No.6, No.9, No.11) had members of the mosque community participate in physically renovating the building by themselves while the remaining mosques hired Japanese contractors.

2.3.2 People

The construction of the mosque requires financial assistance. The mosques can be placed in three categories according to the method in which they were funded^{*2}: Government Based (GB), Community Charity (CC) and Community with External Assets (CE). In Government Based, the government of a specific country undertakes the responsibility of the mosque (No.2, No.5). The purchase of the land, construction of the building and the mosque's internal administration is all done by the government organization. In Community Charity mosques, a group of people pool their resources to purchase or rent the space for the mosque and undertake all associated modifications to the building as well as the administration (No.6, No.8). In Community with External Assets, a group of people

2. SPATIAL PRACTICES OF MOSQUES IN TOKYO

are supported by a government or non-governmental organization to establish a mosque (No.1, No.3, No.4, No.7, No.9, No.10, No.11). In the administration of the mosques, five are done so by organizations (No.1, No.2, No.5, No.6, No.10). The remaining mosques have the responsibility of the religious and administrative management taken by an official committee (No.3, No.8, No.9, No.10, No.11) or a volunteer group (No.4, No.7). The Imam is often part of this group. He is responsible for leading the prayers and managing religious activities that take place within the mosque. The Imam is usually selected according to the needs of the visitors to the mosque, as language and culture can be barriers in a foreign country. For example, in Tokyo Camii (No.2), the Friday Khutbah is given in English and Japanese. Much of the information literature, such as educational pamphlets, use English, Japanese and Turkish. The Indonesia mosque (No.10) which has been built next to the Indonesian school primarily uses the Indonesian language. Dar-Al-Arqam (No.1), established by a group of Pakistani people, uses both a combination of Urdu and English.

2.3.3 Activities

Mosques in Tokyo encourage their use by holding activities, such as communal meals during the month of Ramadan and the biannual celebrations of Eid. Food often poses an issue for the Muslim community living in Tokyo, which is why many activities are centered around communal meals. Two out of the eleven of the mosques have employed chefs (No.5, No.7) while the remaining have free meals prepared or donated by volunteers. Ramadan is when Muslims fast for the entire month. The sunrise and sunset meals are provided by the mosque, in addition to different lectures and prayers being held. Friday is considered as the day for communal prayers and sees an increase in the number of visitors, often maximizing the capacity of the mosque. While numbers for daily visitors could not be determined, the number of visitors on Fridays and during Eid were available as the administrations need to calculate the capacity of the mosque. In order to accommodate these cyclical fluctuations, each of the mosques have developed their own space management systems. For example, on Friday in a Muslim majority country, the noon prayer of Zuhr is given only once as there are mosques in every neighbourhood. On the other hand, on Friday in Tokyo, the Zuhr prayer is given multiple times in some of the mosques. This is due to the fact that the small number of mosques scattered across

2. SPATIAL PRACTICES OF MOSQUES IN TOKYO

the city. Their size is also quite small and cannot fit the number of worshippers who make a special trip for Friday prayers. Therefore, to ensure everyone has their turn, the prayers are given in shifts, using the other rooms that are usually reserved for classes and other activities for Salat.

By looking into the management of the mosques, it is seen that there is a degree of involvement of the worshippers in the different phases of establishment, such as physically building the mosque, financial assistance or volunteering in the administration. In spite of the language barriers, the visitors who worship at the mosque and participate in the activities are highly diverse. Participation is also stimulated by the activities as by holding communal meals, celebrating religious days and social gatherings, the mosques strengthen ties between its members.

2.4 Adaptations of Mosques in Tokyo

In order to understand how the architectural norms are translated in the mosques in Tokyo, the Kamata mosque will be analyzed.

2.1 Analysis Example of Kamata Mosque (No.8)

Kamata mosque is an existing renovated three-storey building (Fig. 3). It is established by the community [CC]. This mosque does not have a physical Minaret. Instead, one is painted on the building facade. The Wudu area adapted an existing room on the ground floor, installing a row of taps with drainage and adding plastic seats to facilitate the cleansing ritual. Showers and toilets have also been installed. Within the Salat area, women and men are separated by floor. The ground floor is for women (W) and the first floor, which is the men's area (M), there is the Mihrab and the Minbar. The Mihrab is a decorated niche and a specifically made Minbar is for the Imam to use during Khutbah. Besides these architectural norms, there are also other functions included in the Kamata mosque. The Kitchen is where the community prepares food for events. There is also the Imam's accommodation where guest imams may use. The current Imam resides in the neighborhood (Fig. 4).

By this overview of Kamata mosque, we can see how the basic requirements to be considered a mosque can be fulfilled through the modifications of the building and furniture.

2. SPATIAL PRACTICES OF MOSQUES IN TOKYO

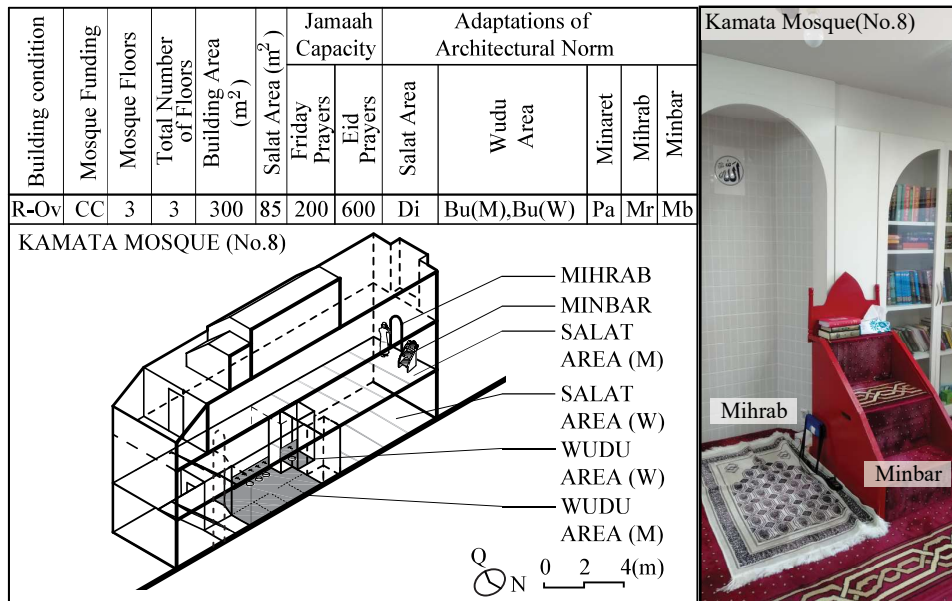

Fig 2.3 Analysis Example: Kamata Mosque (No.8)

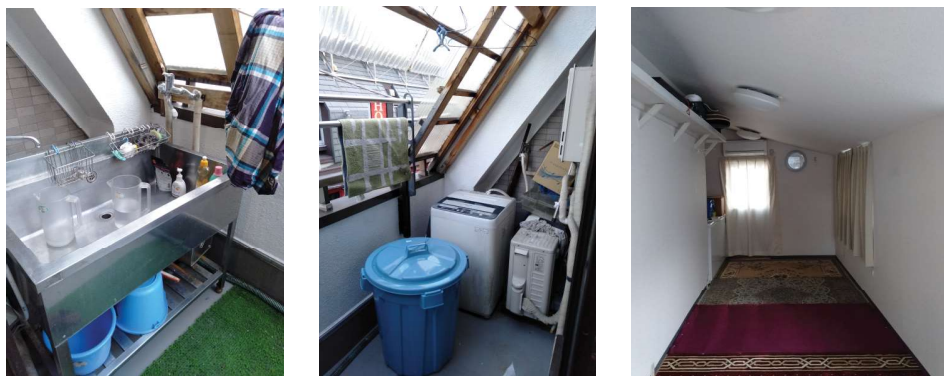

Fig 2.4 Kamata Kitchen (left, centre). Imam accommodation (right)

2. SPATIAL PRACTICES OF MOSQUES IN TOKYO

2.4.2 Adaptations of Architectural Norms within Mosques

Throughout the Muslim world, there is a great variety found in the designs of mosques. However, as mentioned before, that in order for the building to be used as one, there are the key architectural norms that must be maintained.

The Mihrab wall and the spatial practice of Salat

In mosques, physical space and behavior are inextricably linked. The practice of Salat must be done facing the Ka'abah in the city of Makkah. This axis, between the worshipper and the Ka'abah, is called the Qibla axis (Fig. 1). Ideally, the Salat space must have one wall perpendicular to the Qibla axis¹⁰⁾, enabling the worshippers to stand shoulder-to-shoulder facing Makkah, called the Mihrab wall. The Mihrab becomes a crucial device as it indicates which direction to face to properly perform within a building.

In a Muslim majority country, the typical mosque does not follow the urban grid but orients the Mihrab wall perpendicular to the Qibla axis. However, in Tokyo, the urban grid heavily influences the plot or building. Fig. 5 shows the orientation of the 11 mosques in Tokyo with their addresses. The Qibla (Q) axis is shown on the North arrow diagram. The Mihrab should be aligned with the Qibla axis. However, as seen in Figure 5, it is not always achievable in the condition of Tokyo. The building of the mosque in Tokyo must negotiate the orientation requirement of the Salat area, while also ensuring that internal space is used optimally. This results in an imperfect orientation of the Mihrab with the direction of Makkah, along the Qibla axis, even in the cases of purpose-built mosques.

Practices and the Adapted Architectural Norms

Each of the eleven cases was studied through the same lens to clarify the adaptations of architectural norms within the mosques in Tokyo. The adaptations of the architectural norms (Fig. 6) that were recorded in the case studies are below:

Practice of Adhan: In a Muslim majority country, the Adhan is an accepted practice. But a loud religious audio announcement five times a day cannot be given in Tokyo. Thus, the Minaret and its function has had to be adapted to the local condition as it is as an important architectural feature of a typical mosque. Three adaptations are seen: Typical Minaret [Mnr], the design and form of

2. SPATIAL PRACTICES OF MOSQUES IN TOKYO

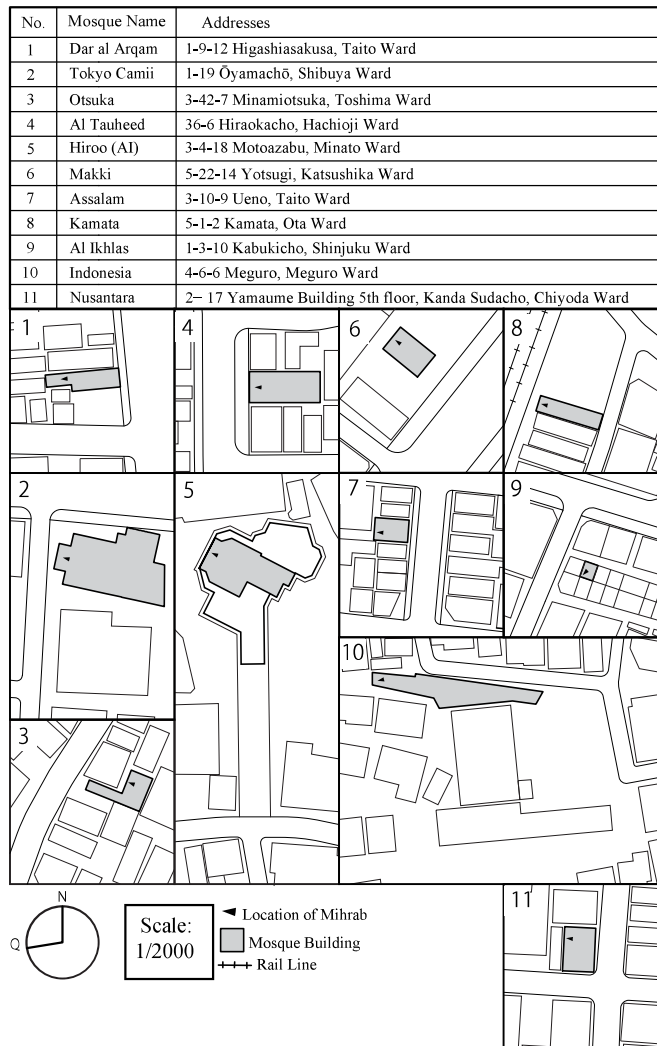

Fig 2.5 Orientations of the Mosques in Tokyo according to the Qibla axis

2. SPATIAL PRACTICES OF MOSQUES IN TOKYO

the minaret follows that of a Muslim country's Islamic architecture (No.2); Object [Ob], the Minaret devolves into an object that is attached to a building (No.1, No.3, No.4); Painted [Pa], a Minaret is painted on the façade of the building (No.6, No.7, No.8).

Practice of Wudu: The location of the Wudu area must be adjacent to the Salat, as the practice of Wudu comes before the practice of Salat. The Wudu area also needs to negotiate the practical requirements of water and drainage infrastructure, especially in renovated buildings, while being appropriately adjacent to the Salat area. This ritualistic cleanse requires the person to wash their hands, head, and feet. A place for Wudu often requires seating so that people may wash their feet comfortably. The Wudu area is separated for women (W) and men (M). This separation address two factors: (1) Many Muslim women wear the hijab, a head covering that must not be removed in front of non-family men but can be removed in front of non-family women. (2) Close proximity to the women's Salat area. In Tokyo, the mosques had two adaptations: Built-In [BI] (No. 2, No. 3, No.5, No.6, No.7, No.8, No.10), seating is built in alongside the water taps and drainage; and Ready-made Products [RP] (No.9, No. 11), where stools and other such products are bought and used. Some mosques have a combination of both (No.1, No. 4).

Practice of Salat: The main purpose of a mosque is to provide a place to practice Salat in groups that are divided by gender. Three adaptations were found: One Room [On], where the Salat is a single area (No. 6, No. 11). Nusantara (No.11) uses a curtain to divide the genders and uses a TV monitor system to provide a connection to Imam for the women's area; Mezzanine [Me], where the areas for women and men were separated by a mezzanine but maintained a visual connection from the upper area to the lower floor (No.2, No. 4, No. 5); and Divided by Floor [Di], where the areas occupied different floors (No. 1, No. 3, No.7, No. 8, No. 9, No. 10) and use TV monitors to connect the spaces. (Fig.7)

Domed ceilings play a significant symbolic role in Islamic architecture, seen in historical mosques of Iran, India and Arab countries such as Syria and Saudi Arabia¹¹⁾ but is not a liturgical device and has no direct relation with the ritual practices¹²⁾. In the mosques of Tokyo, out of eleven case studies, only Tokyo Camii (No.2) was successful in creating a typical domed ceiling of the Salat area, remi-

2. SPATIAL PRACTICES OF MOSQUES IN TOKYO













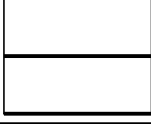

MINARET			WUDU AREA	
Minaret [Mnr]	Object [Ob]	Painted [Pa]	Built-In [BI]	ReadyMade[RM]
				
SALAT AREA				
One Room [On]		Mezzanine [Me]	Divided [Di]	
				
MIHRAB				
Mihrab [Mr]	Corner [Co]	Wall [Wa]		
				
MINBAR				
Minbar [Mb]	Gazebo [Ga]	Podium [Po]	Chair [Ch]	
				

Fig 2.6 Adaptations of Architectural Norms



Fig 2.7 Women's Jammah in Assalam Mosque using a TV monitor to watch the Imam's sermon

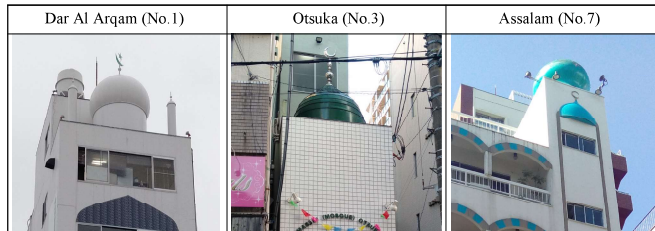

Fig 2.8 Domes of Tokyo Mosque

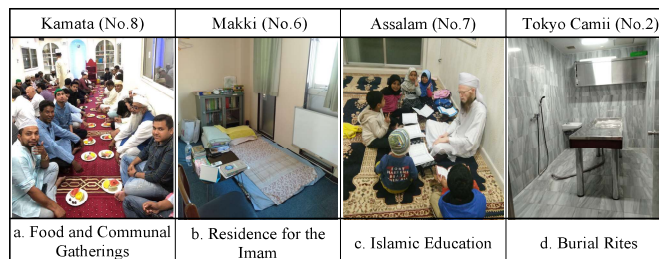

Fig 2.9 Miscellaneous Rooms

2. SPATIAL PRACTICES OF MOSQUES IN TOKYO

niscient of mosques found in Turkey. In three other mosques (No.1, No.3, No.7) takes on an ornamental role, often being attached alongside a Minaret to the exterior. (Fig. 8).

Mihrab: The Mihrab is an interior architectural norm that denotes the direction of Makkah. It is located in the men's Salat area as the Imam is usually male. Three adaptations were found: Mihrab [Mr], where the niche in the wall is maintained (No. 2, No 5, No.7, No.8); Corner [Co], a particular corner or niche of an existing building is modified to signify the direction of Makkah and acts as a mihrab (No.1, No.9, No.10); Wall [Wa], where the flat surface of the wall is marked with posters, curtains or whiteboards to represent the Mihrab (No. 3, No 4, No.6, No.11).

Minbar: This is a tool for the Imam to give a sermon. Three adaptations were found: Minbar [Mb], which was closest to the original form (No.1, No.2, No.6, No.8, No.9); Gazebo [Ga], a unique form of the device (No. 5); Podium [Po] or chair [Ch], where a standard podium or ordinary chairs were used (No. 4, No.7, No. 10, No.11).

2.4.3 Miscellaneous Rooms

The Muslim residents face similar issues while living in Tokyo and the mosque takes the role to address the collective needs (Fig. 9):

a) **Food and Communal gatherings:** Muslims have dietary restrictions due to their religion and many mosques have communal meals as part of their program as a socializing opportunity for its members. For example, Otsuka Mosque (No.3) holds a communal meal after evening prayers every Saturday. The ingredients for the meal are purchased by the mosque's fund and is prepared by volunteers of the mosque. For this practice, the kitchen [K] becomes of paramount importance as the food is prepared and served in-house. Tokyo Camii (No.2), a relatively large mosque, has a small halal food market within in addition to the kitchen. The market is a source of income for the mosque.

b) **Residence for the Imam:** The Imam can be considered as a representative of the mosque. He needs constant access to the mosque to lead the daily prayers and is involved in all the activities. As it is difficult to find human resources that are qualified in Islamic education within Japan, imams are usually invited by the adminis-

2. SPATIAL PRACTICES OF MOSQUES IN TOKYO

tration from other countries. In such a case, the Imam's accommodation [Ia] is provided by the mosque. In some instances, such as Makki mosque, it is provided within the mosque.

c) Islamic Education: Formal Islamic education is not available in Tokyo and many mosques undertake to provide some basic understanding of its principles to children and adults. For that reason, amenities such as libraries [Lb] are included to keep multilingual literature about the Islamic religion, multipurpose rooms [Mlt] and class rooms [Cr] to conduct classes, events and seminars.

d) Burial Rites: Muslims have specific rituals in place following the death of a member of their religion. As institutions facilitating these rituals are not available in Tokyo, it has become part of the mosque as the Jenazah room [Jr] in the Dar Al Arqam (No.1), Tokyo Camii (No.2) and Al-Tauheed (No.4) mosques. Here, the remains of the deceased are cleansed according to Islamic rituals before burial.

The above analysis clarifies the modifications the architectural norms undergo in order to adapt the spatial practices of the behavioral norms to the context of Tokyo (Table 3).

2.5. Adaptation Patterns of the Case Studies

2.5.1 The Sequence of Architectural Norms within Mosques

As mentioned in the section of Methodology, a sequence of behavioral norms is followed in a mosque. In Table 3, this sequence that takes place from the practice of Adhan to the practice of Salat is explained as it occurs in the mosques in Tokyo. Table 3 shows the number of floors in the building that are used as the mosque and how much of the total building area (m²) of each mosque is dedicated to the practice of Wudu and Salat. The entrance is either visible from the street [On street] or hidden within the building [Hidden]. There may be a single entrance, or multiple, or it is separated by gender. After entry, women and men separate towards their respective Wudu and Salat areas. Circulation-I connects the entrance to the Wudu area. Circulation-II connects the Wudu and Salat areas. The separation of women and men along the sequence is termed as "branching."

Makki (No.6) has no space allotted for women within the mosque. Kamata (No.8) begins branching at the entrance that is separated

2. SPATIAL PRACTICES OF MOSQUES IN TOKYO

Table 2.3 Pattern Analysis of Architectural Norms within Mosques

No.	Mosque Name	Building Condition	Mosque Funding	Building Area (m ²)	Number of Floors	Mosque Floors	Wudu Area (m ²)			Salat Area (m ²)			Sequence of the Architectural Norms							Miscellaneous Rooms	Patterns
							M - Wudu Area	W - Wudu Area	M + W - Wudu Area	M - Salat Area	W - Salat Area	M + W - Salat Area	Minaret	Entrance	Circulation - I	Adaptation of Wudu area	Circulation - II	Adaptation of Salat area	Mihrab		
6	Makki	Ov	CC	409	3	3	3.4	-	53	-	Pa	Street level	Corridor - men	BI - G.Fl - men	Corridor - men	One room	Wa	Mb	K, Ia, Mt, Cr	A	
11	Nusantara	RPa	CE	67	7	1*	1.8	1.8	45.2	14.1	-	Hidden single	Stair	BI - 5th Fl - men RP - 4th Fl - women	None - men Stair - women	One room - 5th Fl	Wa	Ch, Po	-	B	
2	Tokyo Camii	N	GB	758	3	3 (Me)	15	15	234	50	Mnr	On street multiple	Corridor - shared	BI - G.Fl - men BI - G.Fl - women	Corridor - men Stair - women	G.Fl - men Me - women	Mr	Mb	K, Mt, Cr, Hm, Jr	C	
5	Hiroo (AI)	NPa	GB	187	6	2** (Me)	7.2	7.2	178	48.5	-	Hidden multiple	Corridor - men Stair - women	BI - G.Fl - men BI - 1st Fl - women	Corridor - men Corridor - women	G.Fl - men Me - women	Mr	Ga	K, Cr.		
4	Al Tauheed	N	CE	381	3	3 (Me)	5.6	3.6	81.8	58.2	Ob	On Street multiple	Corridor - men Stair - women	BI - G.Fl - men RP - 2nd Fl - women	Stair - men None - women	1st Fl - men Me - women	Wa	Ch	K, Ia, Mt, Jr	D	
3	Otsuka	Ov	CE	288	4	4	5.2	1.1	50.4	35	Ob	On Street single	Stair - men Corridor - women	BI - 1st Fl - men BI - G.Fl - women	Stair - men Corridor - women	Di - 1st + 2nd Fl - men Di - G.Fl - women	Wa	-	K, Ia, Mt, Cr, Lb	E	
10	Indonesia	N	CE	154	3	3	5.5	5.5	99	100	-	On Street single	Corridor - men Stair - women	BI - G.Fl - men BI - Basement - women	Corridor - men Corridor - women	Di - G + 1st Fl - men Di - Basement - women	Co	Ch, Po	-		
8	Kamata	Ov	CC	300	3	3	4.4	0.7	60.4	24.1	Pa	On street Separated by gender	Corridor - men Corridor - women	BI - G.Fl - men BI - G.Fl - women	Stair - men None - women	Di - 1st + 2nd Fl - men Di - G.Fl - women	Mr	Mb	K, Ia	F	
7	Assalam	Ov	CE	234	5	5	6.5	2.8	74.4	30.5	Pa	On street multiple	Stair - men Stair - women	BI - G.Fl - men BI - 1st Fl - women	Stair - men None - women	Di - 2nd Fl - men Di - 1st Fl - women	Mr	Ch	K, Ia, Mt, Cr		
1	Dar al Arqam	Ov	CE	358	5	5	6.1	4.1	54.9	43.5	Ob	On street multiple	Stair - men Stair - women	BI - 1st Fl - men RP - 1st Fl - women	Stair - men Stair - women	Di - 2nd Fl - men Di - 1st Fl - women	Co	Mb, Po	K, Ia, Mt, Cr, Jr		
9	Al Ikhlas	Ov	CE	36	3	3	1.5	9.6	9.6	-	-	On street single	Corridor	RP	Stair	Di - 2nd Fl - men Di - 1st Fl - women	Co	Mb	K, Mt	G	

*) Only 5th Floor is used as the mosque **) Only 1st and 2nd Floors are used as the mosque

Legend for Table 3

Funding	Building	Minaret	Wudu Area	Salat Area	Mihrab	Minbar	Miscellaneous Rooms
CC Community Charity	N New NPA New partial	Mnr Minaret Ob Object	BI Built-In RP Ready-made	On One Room Me Mezzanine	Mr Mihrab Wa Wall	Mb Minbar Ga Gazebo	K Kitchen Ia Imam accommodation
CE Community with External Assets	Ov Overall Renovated	Pa Painted	Products G.Fl Ground Floor	Di Divided by Floor	Co Corner	Ch Chair Po Podium	Mlt Multipurpose room Cr Classroom
GB Government Based	RPa Renovated - partial		Fl Floor				Lb Library Hm Halal Market

by gender. In Al Ikhlas (No.9), both men and women use the same circulation and Wudu area but branch off only in the Salat area. With Nusantara (No.11) the branching begins with the separation of the Wudu areas. Tokyo Camii (No.2) has women and men share circulation but maintains the separation of Wudu and Salat areas by gender. In the remaining six cases (No.1, No.3, No.4, No.5, No.7, No.10) the branching begins at Circulation-I.

It is seen that the respective Wudu areas for women and men come sequentially before the respective Salat areas by occupying the same or lower floors. In four cases (No.1, No.4, No.7, No.8), the women's Wudu area opens directly into their Salat area without Circulation-II. This adjacency reinforces the sequence of behavioral norms where Wudu is performed before the Salat.

The above analysis clarifies that the modifications of the architectural norms in the condition of Tokyo facilitate the spatial practices of a mosque. Conflicts arise when transposing the requirements of

2. SPATIAL PRACTICES OF MOSQUES IN TOKYO

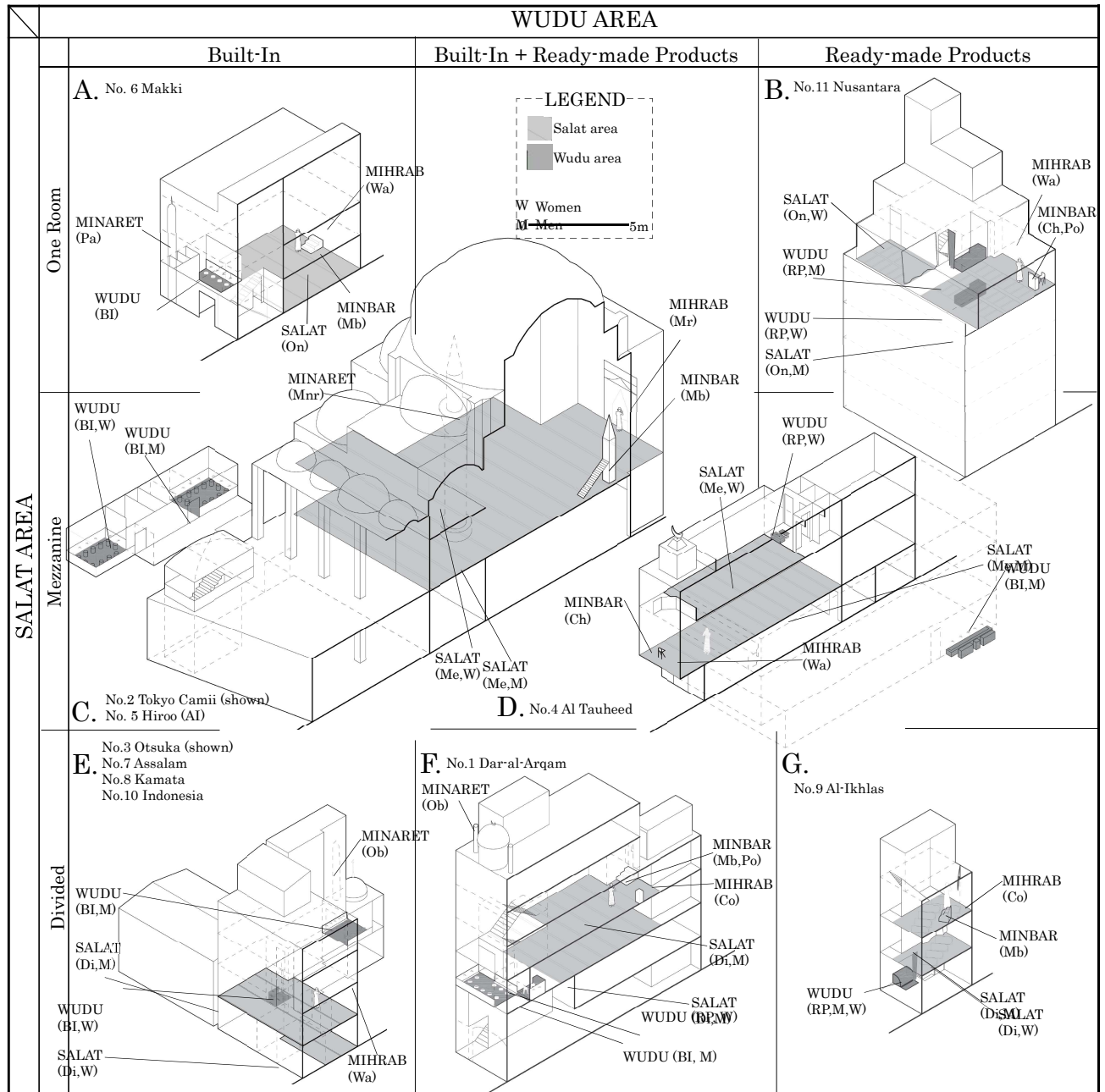

Fig 2.10 Patterns of Adaptation of Mosques in Tokyo

2. SPATIAL PRACTICES OF MOSQUES IN TOKYO

a mosque onto the physical condition of Tokyo. The behavioral norm that encounters the public, such as people using the street, nearby residents as well as schools or shops, the Adhan, is removed. In the case studies, only Tokyo Camii has a traditional Minaret but cannot perform the vocal announcements. All others have Minarets reduced to only visual markers. Within the mosque building, the architectural norms have degrees of adaptation. The Wudu area is an important factor that cannot be removed. It often needs to be renovated as seating is required for the behavioral norm of the Wudu. Seven out of 11 mosques had Built-In Wudu areas (No. 2, No. 3, No.5, No.6, No.7, No.8, No.10) and two used a combination of Built-in with ready-made products (No.1, No. 4).

The separation of women and men is maintained in all of the 11 mosques in both Wudu and Salat areas. Only mosques with Mezzanines in the Salat areas (No.2, No.4, No.5) had a direct visual connection between women's area to the Imam in the men's areas. Only four mosques have typical Mihrabs (No.2, No.5, No.7, No.8), while the remaining have simplified versions of marked walls or corners. Five (No.2, No.6, No.7, No.8, No.9) out of eleven mosques used Minbars since these devices are not commonly found and require to be specially made. These adaptations are done according to the financial assistance available to the mosque.

The primary function of the mosque is to provide a space for the communal practice of Salat. Thus, the Salat and Wudu areas become crucial factors in a mosque and were taken to organize the 11 case studies into seven patterns (Table 3).

- Pattern A: Salat area is One room and Wudu area is Built-In.
- Pattern B: Salat area is One room and Wudu area has Ready-made Products.
- Pattern C: Salat area has a Mezzanine and Wudu area is Built-In.
- Pattern D: Salat area has a Mezzanine and Wudu area has a combination of Built-In and Ready-made Products.
- Pattern E: Salat area is Divided by floor and Wudu area is Built-In.
- Pattern F: Salat area is Divided by floor and Wudu area has a combination of Built-In and Ready-made Products.
- Pattern G: Salat area is Divided by floor and Wudu area has Ready-made Products.

2. SPATIAL PRACTICES OF MOSQUES IN TOKYO

Using the patterns, the mosques can then be arranged in the matrix (Fig. 10) according to the Wudu and Salat areas. For the Wudu areas, the horizontal axis is composed of the categories of Ready-Made, Built-In and the combination of Built-In+ Ready-made Products. The vertical axis relates to the adaptations found in the Salat area: One Room, Mezzanine and Divided. The matrix of Fig. 10 elaborates the variety found in the Tokyo mosques, in scale, in building form as well as the combinations of adaptation of the architectural norms that they use. An example of each pattern is shown.

2.5.2 Architectural Expression and the Relationship between Mosque Management and the Adaptations of the Architectural Norms

Taking the clarification of the adaptations of the architectural norms alongside the information discussed through Building, People and Activities in the management of the mosques, it is seen that while all mosques provide a space for the communal Salat, they are not identical and have additional aspects which differentiate one from the other.

Tokyo Camii (No.2) prioritizes Turkish national identity in addition to its Islamic identity. Its origins are celebrated as Turkish artisans and craftspeople were invited to be involved the construction. Within the mosque, the Salat area is the central space beneath the greatest dome, reminiscent of Turkish mosques, with the Wudu areas purpose built and neatly tucked away. The Minbar and Mihrab are replicas of those found in Turkish Ottoman mosques and are purpose built devices to facilitate the ritual of Salat and Khutbah. Hiroo (No.5) and Indonesia mosque (No.10) also refer to their Islamic religion alongside their culture. However, they are annexes, Hiroo mosque being part of the Arab Institute and Indonesia mosque being part of the Indonesian school.

On the other hand, there are mosques that formed by the efforts of local Muslim residents in Tokyo independent of one culture or country. Dar al Arqam (No.1), Otsuka (No.3), Makki (No.6), As-salam (No.7), Kamata (No.8), Nusantara (No.11) all appropriated commonly found office buildings into a religious facility. The local Muslim residents participate in establishing the mosque, either through financial assistance, or physically building the mosque or

2. SPATIAL PRACTICES OF MOSQUES IN TOKYO

taking part in administrative decisions. In order to communicate the Islamic identity, generic forms Minarets or domes were either attached or painted onto the facade of the building. The variations of the architectural adaptations of the Mihrab are used according to the financial ability of the mosques and common objects such as chairs or podiums may be used as Minbars. This appropriation of buildings and furniture to facilitate the spatial practices of Salat and Wudu indicates the versatility of the mosques. In contrast to Tokyo Camii, the mosques do not promote a single nationality.

Thus, while the mosques share their goal in providing a space for communal Salat to visitors of diverse backgrounds, their management and methods of architectural adaptations enable them to reflect a particular country or focus only on the Islamic religious identity.

2.6 Conclusion

Japan, being a non-Muslim majority country has a small number of mosques, which differ in scale, methods of establishment, and architectural expression. As religious facilities, they have architectural norms that are used if the behavioral norms are to be practiced correctly. These mosques transpose architectural norms of typical mosques found in Muslim majority countries onto the local available physical setting in Tokyo. This study focuses on how architectural norms of mosques are modified when encountering the building and social conditions of the Tokyo to ensure that the unchangeable ritual behavior can be practiced.

It was determined that a typical mosque found in Muslim majority countries cannot be perfectly replicated in Tokyo, with conflicts arising between the typical architectural norms and the urban condition.

There were varying degrees of adaptation in the mosque building. In the behavioral norm of Adhan, the associated architectural norm of the Minaret was reduced to only being visual marker and the vocal practice of Adhan was removed. The architectural norm of the Wudu area has only the basic requirements for the behavioral norm of Wudu and cannot be removed. In the case of a renovated building, it must negotiate with the existing infrastructure while being situated adjacent to the Salat area. Both the Wudu and Salat

2. SPATIAL PRACTICES OF MOSQUES IN TOKYO

areas are separated by gender. As the Imam is in the men's Salat area, this separation forces renovated mosques to rely on devices like TV monitor systems to connect the two Salat areas. Only the three mosques that had Mezzanine levels could provide a direct connection between the Imam and women's Salat area. Within the Salat area, only four mosques had conventional Mihrabs, while the remainder marked walls or corners to show the direction of Makka. Five mosques had Minbars while the remaining used chairs or podiums instead.

The analysis clarifies that it was the architectural norms that had to be adapted for the optimal performance of the behavioral norms, whether the building is purpose-built as a mosque or an existing building renovated into one. It was determined that the Salat and Wudu areas are crucial factors in the mosque. Thus, they were used to categorize the mosques into seven patterns from A - G. The variety of patterns informs of the different manner and combinations in which the architectural adaptations can be executed when responding to Tokyo's conditions.

The mosques share a similar goal, i.e., to provide a space for the practice of Salat in a communal way, negotiating with the limitations they face in Tokyo. Yet they are not identical to one another. Some prioritize a nationality in addition to the religion while others focus solely on their Islamic religious identity.

The number of mosques remains small in Tokyo but they give us the opportunity to analyze how the architectural norms are modified in order to accommodate the behavior of spatial practices.

2. SPATIAL PRACTICES OF MOSQUES IN TOKYO

References

1. Komai, H.: Foreign migrants in contemporary Japan, Trans Pacific Press. 2001
2. Tanada, H.: Mosques of Japan, Social Activities of Muslims in Japan, Yamakawa Publishing 2017 (In Japanese) 店田廣文：日本のモスク，滞日ムスリムの社会的活動，山川出版社 2017
3. Tanada, H., Okai, H.: Islam of Japan, Current status and issues of Muslim Communities in Japan, Shumu Jiho 119, pp. 1-22, 2015.3 (In Japanese) 店田廣文，岡井 宏文：日本のイスラム，ムスリムコミュニティの現状と課題，宗務時報 (119), pp. 1-22, 2015.3
4. Okai, H.: Establishment of Religious Institutions by Muslim Immigrants in Japan, Waseda Journal of Human Sciences 22-1, pp. 15-29, 2009 (In Japanese) 岡井 宏文：滞日ムスリムによる宗教的基盤の獲得と変容 - モスク設立活動を中心に -，人間科学研究，第22巻，第1号，pp. 15-29, 2009
5. Amin, A.: From Mushalla to Mosque, The Formation of South and Southeast Asian Muslim Communities in Japan, Al-Albab, 8(1), pp. 3 - 20, 2019
6. Kawazoe, W.: Study on the Role and Expansion of Islamic Facility in Japan, in the Era of Foreigner Settlement, A Case Study In Masjid Otsuka in Toshima-ward, Tokyo, The New Geography, 65(3), pp. 16-33, 2017 (In Japanese) 外国人定住化時代におけるイスラーム系宗教施設の役割とその拡大 - 東京都豊島区 [マシジド大塚] を事例として，新地理 65-3, pp. 16-33, 2017
7. Lefebvre, H.: The Production of Space, translated by Donald Nicholson-Smith, Blackwell Publishers, 1991
8. Knott, K.: The Location of Religion, Durham, Acumen, 2005
9. Frishman, M., Khan, H., Al-Asad, M.: The mosque, history, architectural development and regional diversity, Thames and Hudson, 1994
10. Kahera, A., Abdulmalik, L., Craig.: Design Criteria for Mosques and Islamic Centers: Art, Architecture and Worship, Elsevier Ltd, 2009
11. Hillenbrand, R.: Islamic Architecture: form, function and meaning, Edinburgh University Press, 1994
12. Tajuddin, M and Rasdi, M: Rethinking the Mosque in Modern Muslim Society, Institute Terjemahan Negara Malaysia, 2014
13. Stierlin, H., translated by Kamiya Takeyo: Architecture De L'Islam, Hara-Shobo, 1987 (In Japanese) アンリ・スチールラン. 神谷武夫訳. イスラムの建築文化. 原書房. 1987

Notes

- *1) Tanada listed eight mosques and this study found an additional three examples.
- *2) Tanada explained there are four types of establishment methods of mosques in Japan: Country-based, Community with personal charity's, Community base personal assets, Community and external assets and Foreign students community.

3. SPATIAL PRACTICES OF SOUTH ASIAN COMMONALITIES FORMED THROUGH FOOD AND PRAYER WITHIN TOKYO

食と祈りを通して形成される南アジアの共同性の空間的実践

Abstract

This study examines the spatial practices of the facilities of South-Asian ethnic grocery shops, restaurants and prayer venues in order to clarify the food and prayer commonalities in Tokyo. The relationship between the concentration of the three facilities and the train stations of their location is termed as a “cluster”. Six clusters were found in Tokyo: NishiKasai, Okachimachi, Ikebukuro, ShinOkubo, Kamata and Jujo. The spatial practices of the facilities articulate their own identity as well as that of the clusters. By drawing comparisons between them, it is seen that the clusters affect the character of the urban setting of Tokyo.

3. SPATIAL PRACTICES OF SOUTH ASIAN COMMONALITIES FORMED THROUGH FOOD AND PRAYER WITHIN TOKYO

3.1 Introduction

The residents of Tokyo are diversifying in their social, economic and ethnic background. As a global city¹, Tokyo attracts domestic and international workers. According to the Ministry of Internal Affairs, Non-Japanese residents comprise 2.25% of people living in Japan². In order to address the combination of a greying society and a low birthrate, the Japanese government has increased immigration by broadening specific types of work visas³ and the economic success of Japan has attracted migrants leading to an increase in foreign residents.

Migrants entering the country bring items and traditions that can be shared to form commonalities. Commonalities may be defined timeless things and practices that transcend location and create dialogue between people⁴. The commonalities of religion and food, two factors which are deeply intertwined in the lives of migrants, are made tangible by the three facilities of ethnic grocery shops, restaurants and different prayer venues. This report focuses on the intersection of the multiethnic South Asian population that resides in the 23 special wards of the Tokyo and these three facilities, which produce the commonalities of food and prayer in their daily lives.

3. SPATIAL PRACTICES OF SOUTH ASIAN COMMONALITIES FORMED THROUGH FOOD AND PRAYER WITHIN TOKYO

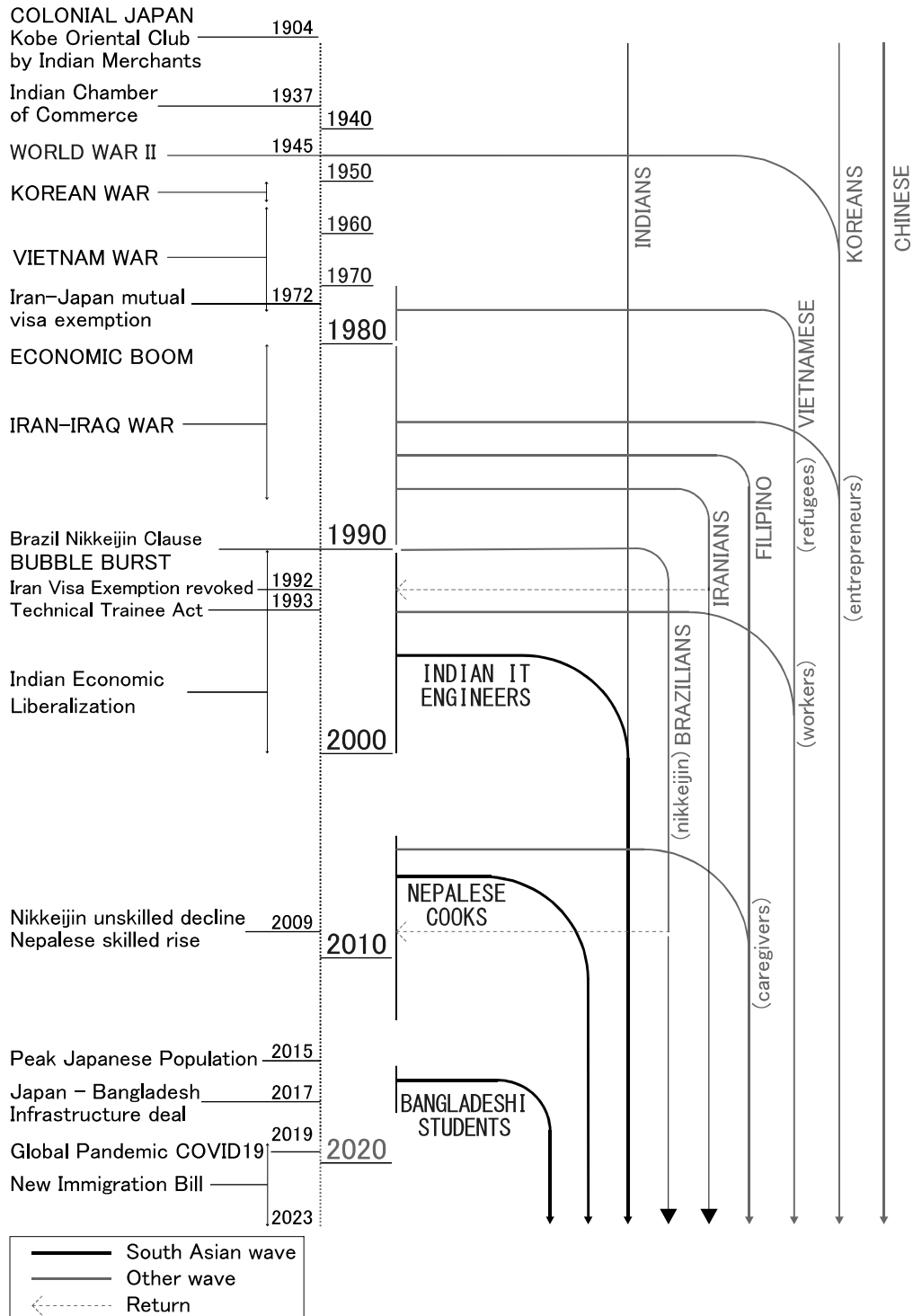

Fig 3.1 History of the Influx of Migrants into Japan

3. SPATIAL PRACTICES OF SOUTH ASIAN COMMONALITIES FORMED THROUGH FOOD AND PRAYER WITHIN TOKYO

3.1.1 Previous Research

Studies on migrants living in Japan discuss the role of food and religion but their relationship with the urban setting remains unexamined. An overview of foreign migrants is given by Komai⁵, where he discusses the history of migration to Japan and the emergence of ethnic communities, their relationship with the government and Japanese society. Focusing on the South Asian diaspora in Japan, Ahmed⁶ discusses migrant life through the four variables of food, work, gender and leisure. By analyzing food as one of the four variables, the author presents how the places where items from their home countries may be purchased are an important factor in the lives and livelihoods of the migrants. Within Tokyo, a study by Azuma examines the different socio-economic and religious communities of Indian nationals and describes how one of the gathering spaces were the religious spaces, especially for the Sikh and the Jain communities⁷. In a separate study, Sawa examines how the Indian community of Nishikasai, that predominantly works in

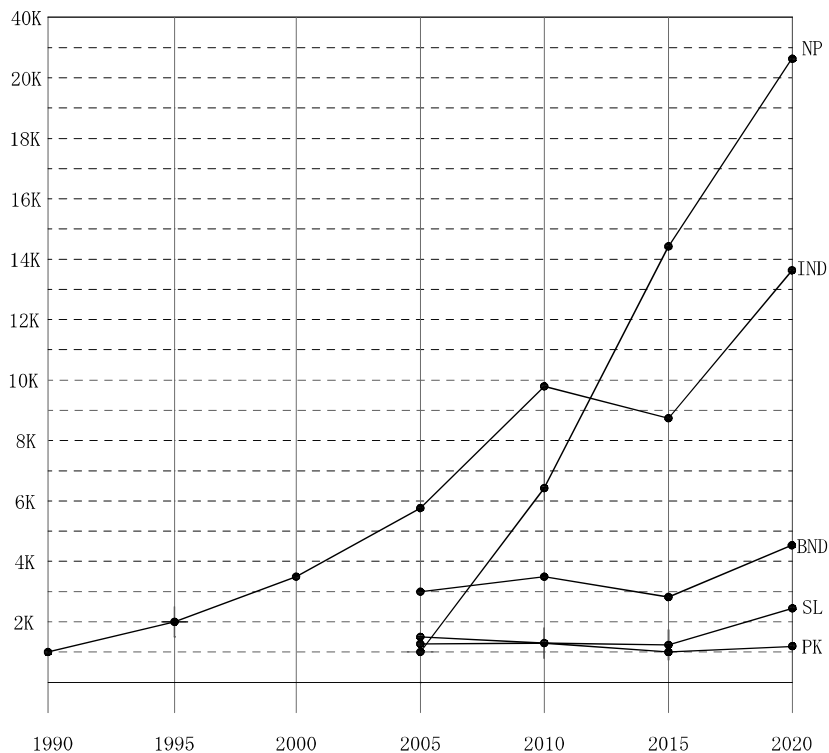

Fig 3.2 Increase in South Asian population in Tokyo
Source: Tokyo Metropolitan Government Bureau of General Affairs Department of Statistics

3. SPATIAL PRACTICES OF SOUTH ASIAN COMMONALITIES FORMED THROUGH FOOD AND PRAYER WITHIN TOKYO

the IT sector, evolved and created their own spaces for living, gathering and education⁸. A study by Kitahara et al⁹. concentrated on Bangladeshi residents living in Urban Renaissance housing in Kita ward and clarified the relationship between the housing and the Bangladeshi residents with the local government's efforts to deal with the new foreigners living in the area.

To understand how these commonalities exist, the spatial practices must be examined. The definition for spatial practices was obtained by Henri Lefebvre's concept of the tripartite production of space, which are the actions that are produced within and structure the lived space¹⁰. It is through these practices that the identity of the lived space is reinforced. Similarly, according to Michel de Certeau describes spatial practices as the movements, routines and rituals that people carry out, articulating the experience of daily life¹¹. Grocery shops, restaurants and prayer venues were investigated to understand how the commonalities formed through food and prayer have their own spatial practices. As discussed by Sloterdijk, the city is an urban macro-foam, composed of layers of non-uniform individual units, each containing a place, a neighbourhood or a world¹². This concept is useful in understanding how migrants appropriate the city of Tokyo and add a new layer by using commonalities of food and prayer.

3.1.2 Objective of the Study

The above studies mention the importance of food and religion in the life a migrants but limit themselves to one type of South Asian community and do not cover the spaces produced by their interaction. The different South Asian communities living in Tokyo cannot be studied in isolation and attention must be paid to their interrelation on an urban scale. The objectives of the study are three-fold: First, to clarify how the commonality of food is articulated in the facilities of ethnic grocery shops and restaurants, while the commonality of religion in the facility of prayer venues. Second, to clarify the practices that take place within them and the resultant identity created. Third, how these facilities affect the character of their area.

3.2 Methodology

The current wave of people from the South Asian region joins the many others that came before to Japan (Figure 1). In the economic boom of the “Bubble Period”, a workforce shortage prompted the government to enable the movement unskilled and skilled workers to the country. Iran and Japan implemented a mutual visa waiver program, encouraging migration. Even though the such foreign workers were excluded from many benefits and worked for the 3K jobs, the availability and high wages of such work made Japan an attractive destination. After the economic collapse, the Immigration and Refugee Act of 1952 was amended in the 1990s. Clauses were added to encourage the Nikkeijin from Brazil and Peru to relocate to Japan while countries such as Iran faced stricter regulations due to visa overstayers. The Technical Intern Training Act was initiated to enable foreign workers to learn technical skills in Japan. Unfortunately, it was exploited for cheap labour with long work hours in unsafe conditions, sparking international and national protest. The government pledged to monitor the situation more closely and amending it in 2016.¹³

In spite of an aging society and a low birthrate in the face of a global pandemic, Japan has not fully embraced immigration as a source of renewal. The positive effects of migrants are tangible in the city of Tokyo. In Shinjuku, a ward with great diversity, Taiwanese and Korean investment kept the area relatively insulated against the recession in the 1990s¹⁴. The presence of a Nepalese restaurant in a typical shotengai or a grocery shop selling Halal⁽⁶⁾ items are signs of how ethnically diverse people are continuing the productivity of Tokyo. There has been a steady increase in the number of South Asian people living in Tokyo (Figure 2) with the Nepalese demographic entering the top ten of the highest foreign-population living in Tokyo.

3.2.1 Field Survey of the Facilities

After compiling ward demographics, the areas with large numbers of South Asian ethnic grocery shops, restaurants and prayer venues were identified. Interviews were held with the owners and visitors to the grocery shops and mosques in 2018-2019 to understand their operation. (Table 1). The owners and staff of South Asian grocery stores were interviewed to ascertain the nature of their link to South Asia and asked about the prayer venues they or their

3. SPATIAL PRACTICES OF SOUTH ASIAN COMMONALITIES FORMED THROUGH FOOD AND PRAYER WITHIN TOKYO

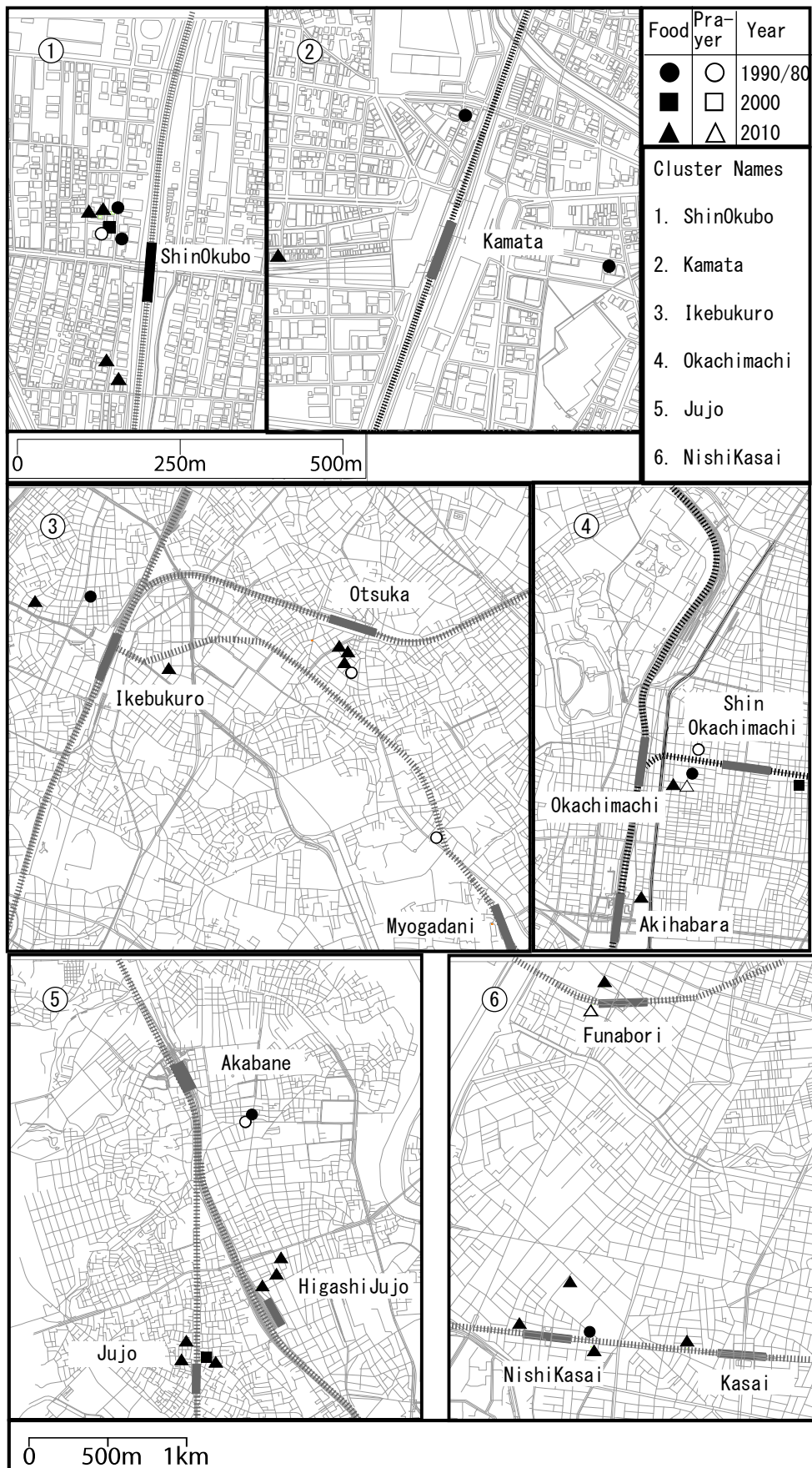

Fig 3.3 Six clusters found in Tokyo

3. SPATIAL PRACTICES OF SOUTH ASIAN COMMONALITIES FORMED THROUGH FOOD AND PRAYER WITHIN TOKYO

customers visited. A list of prayer venues was compiled by online searches and verified by field surveys and interviews. The grocery stores and prayer venues were mapped according to the year they opened. The restaurants that were in a one-kilometer radius of each of the stations were included in the study.

3.2.2 Identification of the Clusters

The scale of this study was on the city level. Data was gathered from across Tokyo to identify six main urban localities where the concentration of the three facilities of grocery shops, restaurants and prayer venues alongside the train stations formed a relationship, termed as a “cluster”, named after one of the main train stations it contains: Nishi Kasai, Okachimachi, Ikebukuro, ShinOkubo, Kamata and Jujo (Figure 3). They are divided into the following three categories: (1) Home-Train Station, where South Asian residents made their homes, (2) Market, where the presence of existing markets encouraged the South Asian shops to start their businesses in the area, (3) Religion, where the establishment of a prayer venue led to many shops opening nearby.

The study focused not on the physical setting but instead the practices that were taking place, which in turn affected the urban character. The characteristics of each cluster is derived by the spatial practices of the three facilities. The framework of Space, Identity and Practice was used to understand their interconnection within each cluster.

For grocery shops, the physical space is determined through the parameters of: Year Established, Floor level, Area (m²) and Ownership. Though all shops sell products, the South Asian ethnic grocery stores specialize their practices according to a target customer, which can be understood through the following factors: Opening Hours, Customer Ethnicity and Related Food Service. Identity of the grocery shop is determined by Items Sold, Owner Ethnicity and Owner's Prayer Venue.

For restaurants, Identity is determined by the cuisine that is served. Space is analyzed by floor level and total number. Practice is analyzed by the vegetarian and halal options offered as it has an influence on the type of customer.

3. SPATIAL PRACTICES OF SOUTH ASIAN COMMONALITIES FORMED THROUGH FOOD AND PRAYER WITHIN TOKYO



Fig 3.4 Barahi grocery shop with associated Nepalese restaurant on the second floor in ShinOkubo

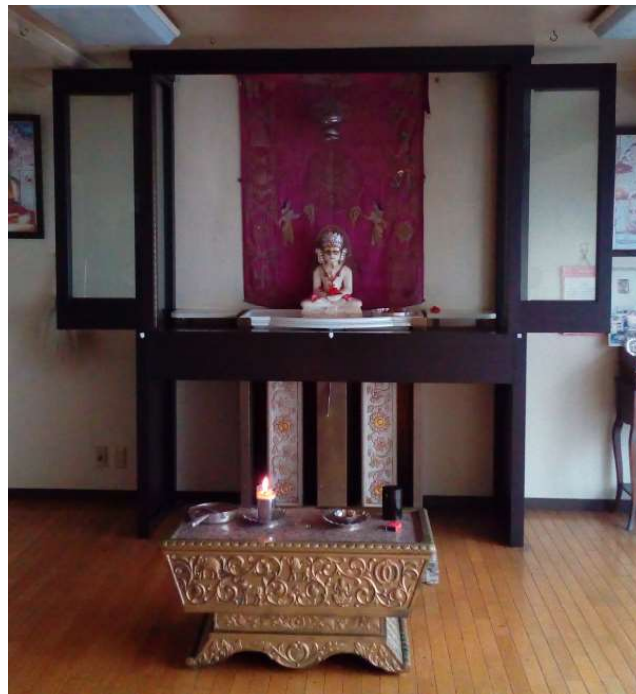

Fig 3.5 Sacred sculptures used in the Jain temple in Okachimachi

3. SPATIAL PRACTICES OF SOUTH ASIAN COMMONALITIES FORMED THROUGH FOOD AND PRAYER WITHIN TOKYO

Table 3.1 The Spaces and Practices of South Asian Commonalities of Food and Prayer

Cluster Name		NISHI KASAI					OKACHIMACHI					IKEBUKURO					SHIN OKUBO					KAMATA					JUJO									
Cluster Formation		Home-Train station					Market					Religion					Market					Home-station					Home-Train station									
Stations		NishiKasai, Kasai, Funabori					Okachimachi, ShinOkachimachi, Kurumae					Ikebukuro, Otsuka, Myogadani					ShinOkubo					Kamata, KeikyūKamata					HigashiJujo, Jujo, Akabane									
Ward Demographics		Edogawa-ku No.:199 Ind:5035 Bd:369 SL:171 Pk:105 Afg:1					Taito-ku No:547 Ind:720 Bd:42 SL:88 Pk:41 Afg:12					Toshima-ku No:2831 Ind:168 Bd:240 SL:142 Pk:49 Afg:-					Shinjuku-ku No:2909 Ind:249 Bd:319 SL:121 Pk:31 Afg:3					Ota - ku No.:22931 Ind:351 Bd:184 SL:124 Pk:75 Afg:1					Kita-ku No.:1286 Ind:212 Bd:1043 SL:60 Pk:42 Afg:-									
GROCERY STORES	SPACE	Store Name	Swagat	TWS	Krishna Palace	Bappu Bazaar	Kikuchi	Ambika	Star Indo	Spicy Food	Tokyo Halal	Al Flah	Buddha Fresh	Manaste Mini	W Halal	Sunshine Halal	Rahmania	Green Masco	Masco Halal	Barahi	AI Jannat	Shinjuku Halal	JB Halal	Kantipur	Asia Bazaar	Indo Bazaar	Nepali Bazaar	Sonali	Baticrom	Mazundar Halal	Asia Halal	Sakura Halal	Jannatu Int.	AI Barakah	Everest	
		Year Est	2005	2011	2016	2017	2018	1998	2006	2014	2018	1987	2012	2013	2014	2016	2018	1992	2016	2001	2007	2012	2014	2017	2002	2006	2014	1998	2003	2016	2016	2018	2018	2018	2018	
		Floor Level	1F	1F	2F	1F	1F	1F	1F	1F	2F	4F	1F	1F	2F	2,3F	1F	1F	1F	1F	1F	1F	1F	1F	2F	2F	2F	1F	1F	1F	1F	1F	1F	1F	1F	
	Area (sq.m)	32	11.5	30	57	30	40.6	57.6	23.8	30.7	43.3	23	10.4	24	11	12.6	16	15	16.6	28	15	26	11.2	17.5	42	11.3	40	90	17.3	15.6	14.4	16.8	17	14.5		
	Owner shtp	○	○	○	○	○	○	○	○	○	○	○	○	○	○	○	○	○	○	○	○	○	○	○	○	○	○	○	○	○	○	○	○	○	○	
	Company																																			
	Operating Hours	09:00																																		
	PRACTICE	Customer Ethnicity	Nepalese	●	●	●	●	●	●	●	●	●	●	●	●	●	●	●	●	●	●	●	●	●	●	●	●	●	●	●	●	●	●	●	●	●
			Indian	ITcm	ITcm	ITcm	ITcm	●	In	●	●	●	●	●	●	●	●	●	●	●	●	●	●	●	●	●	●	●	●	●	●	●	●	●	●	●
			Bangladeshi	●	●	●	●	●	●	●	●	●	●	●	●	●	●	●	●	●	●	●	●	●	●	●	●	●	●	●	●	●	●	●	●	●
Sri Lankan			●	●	●	●	●	●	●	●	●	●	●	●	●	●	●	●	●	●	●	●	●	●	●	●	●	●	●	●	●	●	●	●	●	●
Pakistani			●	●	●	●	●	●	●	●	●	●	●	●	●	●	●	●	●	●	●	●	●	●	●	●	●	●	●	●	●	●	●	●	●	●
Afg + Misc.			●	●	●	●	●	●	●	●	●	●	●	●	●	●	●	●	●	●	●	●	●	●	●	●	●	●	●	●	●	●	●	●	●	●
Oth FoodService			—	—	Rstr	Rstr	Rstr	—	—	—	—	Rstr	—	Izk	—	Ksk	—	Rstr	Ksk	Rstr	—	—	—	Rstr	—	—	Rstr	—	—	—	—	—	—	—	—	
IDENTITY	Owner Ethnicity	Non SA foods	—	—	—	—	—	—	—	—	—	—	—	—	—	—	—	—	—	—	—	—	—	—	—	—	—	—	—	—	—	—	—	—	—	
		Beef	—	—	—	—	—	—	—	—	—	—	—	—	—	—	—	—	—	—	—	—	—	—	—	—	—	—	—	—	—	—	—	—	—	
		Oth. Halal Mt	—	—	—	—	—	—	—	—	—	—	—	—	—	—	—	—	—	—	—	—	—	—	—	—	—	—	—	—	—	—	—	—	—	
		Nepalese	—	—	—	—	—	—	—	—	—	—	—	—	—	—	—	—	—	—	—	—	—	—	—	—	—	—	—	—	—	—	—	—	—	
		Indian	Hn	Hn	Hn	Hn	—	Hn	Jn	—	—	—	—	—	—	—	—	—	—	—	—	—	—	—	—	—	—	—	—	—	—	—	—	—	—	
		Bangladesh	—	—	—	—	—	—	—	—	—	—	—	—	—	—	—	—	—	—	—	—	—	—	—	—	—	—	—	—	—	—	—	—	—	—
		Other	—	—	—	—	—	—	—	—	—	—	—	—	—	—	—	—	—	—	—	—	—	—	—	—	—	—	—	—	—	—	—	—	—	—
Owner Vendors	Communal	Temp	Temp	Temp	Temp	Msq	NA	JTemp	Msq	Msq	Msq	Msq	Msq	Msq	Msq	Msq	Msq	Msq	Msq	Msq	Msq	Msq	Msq	Msq	Msq	Msq	Msq	Msq	Msq	Msq	Msq	Msq	Msq	Msq		
RESTAURANTS	PRACTICE - Options	In	—	—	—	—	—	—	—	—	—	—	—	—	—	—	—	—	—	—	—	—	—	—	—	—	—	—	—	—	—	—	—	—		
		PkIn	—	—	—	—	—	—	—	—	—	—	—	—	—	—	—	—	—	—	—	—	—	—	—	—	—	—	—	—	—	—	—	—	—	
		NpIn	—	—	—	—	—	—	—	—	—	—	—	—	—	—	—	—	—	—	—	—	—	—	—	—	—	—	—	—	—	—	—	—	—	
		Total Number	16	1	5	9	2	1	4	5	14	1	5	1	7	14	2	3	1	1	8	8	1	1	1	1	1	1	1	1	1	1	1	1	1	
PRAYER	SPACE	Religion / Name	Hinduism/ISKON Temple	Islam/ (NishiKasai) Mosallah	Jainism/TokyoJain Temple	Islam/ Assalam Mosque	Islam/ Otsuka Mosque	Sikhism/ GuruNanak Darbar	Islam / (Shin Okubo) Mosque	Islam/ Kamata Mosque	Islam / Baticrom Mosque	Islam/ HigashiJujo) Mosallah																								
		Year Est.	2010	2018	2000	2010	1999	1999	2010	2001	2003	2018																								
		Floor Level	1F	2F	3, 4F	1, 2, 3F	1, 2, 3F	Basement	4F	1, 2, 3F	2F	2F																								
		Initiators	ISKON	Otsuka Msq	In Jn	SL MI	Pk MI	Indian Sikhs	Local Shop keepers	Local MI	Local MI	Local MI																								
		Bldg. Status	Owned	Rented	Owned	Owned	Owned	Rented	Rented	Rented	Owned	Rented																								
	PRACTICE	Time	Sacred	DeityScIp	Scripture	DeityScIp	Scripture	Scripture	Scripture	Scripture	Scripture	Scripture	Scripture																							
			From Or. Country	○	—	○	—	—	○	—	—	—	—																							
			Support (Spr)	IcLmpWkFn	PryMt	IcMImpFn	PryMt	Pry Mt	Pltfm Wk Cloth	Prayer Mats	Prayer Mats	Prayer Mats	Prayer Mats																							
			Ritual	Kir Dar	AbIOrt Pry	Pry w/Spr	AbIOrtPry	AbI Ort Pry	Kirtan	Ablution Orientation Prayers	AbI Ort Pry	AbI Ort Pry	AbI Ort Pry																							
			Gregorian Calendar	Individual	5 pry/day	Tit	5 pry/day	5 pray / day	Individual	5 prayers / day	5 pray / day	5 pray / day	5 pray / day																							
PRAYER	Food in Events	Religious Calendar	Yearly	Diw Dus Ho Nav Jan	Rmd Ed-Ft /Az	NwYr Diw Fasting	Rmd Ed-Ft /Az	Rmd Ed-Ft /Az	Diw Vai Ho	Ramadan EidulFitr / Azha	Rmd Ed-Ft/Az	Rmd Ed-Ft/Az																								
		Food in Daily Life	Veg/no beef	Halal	Veg (v)	Halal	Halal	Avoid Halal	Halal food	Halal	Halal	Halal																								

Glossary:

<p>Ethnicities</p> <p>SA South Asian</p> <p>Np Nepalese</p> <p>In Indian</p> <p>Bd Bangladeshi</p> <p>Pk Pakistani</p> <p>SL Sri Lankan</p> <p>Religions</p> <p>Hn Hindu</p> <p>MI Muslim</p> <p>Bdh Buddhist</p> <p>Jn Jain</p> <p>Food Options</p> <p>Vg Vegetarian</p> <p>HI+ Halal included</p>	<p>Food Services</p> <p>Ksk Kiosk</p> <p>Rst Restaurant</p> <p>Izk Izakaya</p> <p>Customers</p> <p>Stu Students</p> <p>ITcm IT community</p> <p>Wr Worker</p> <p>Txt Target Customer</p> <p>● Primary visitor</p> <p>○ Secondary visitor</p> <p>○ Minor visitor</p>	<p>Objects</p> <p>Or Origin</p> <p>Spr Support</p> <p>ScIp Sculpture</p> <p>Ic Incentive</p> <p>Fn Fan</p> <p>Lmp Lamp</p> <p>Mi Mirror</p> <p>Wk Whisk</p> <p>Pltfm Platform</p> <p>PryMt Praymat</p>	<p>Religious Calendar</p> <p>Diw Diwali</p> <p>Dus Dussehra</p> <p>E-Az Eid-ul-Azha</p> <p>E-Ft Eid-ul-Fitr</p> <p>Ho Holi</p> <p>Vai Vaisakhi</p> <p>Nav Navaratri</p> <p>Jan Janmastami</p> <p>Rmd Ramadan</p> <p>NwYr New Year</p>	<p>Rituals</p> <p>Abl Ablution</p> <p>Dar Darshan</p> <p>Kir Kirtan</p> <p>Lan Langar</p> <p>Ort Orientation</p> <p>Tit Tithi</p> <p>Food in Events</p> <p>Ghl Gahuli</p> <p>Rngl Rangoli</p> <p>Prsdm Prasadam</p>
--------------------------------------------------------------------------------------------------------------------------------------------------------------------------------------------------------------------------------------------------------------------------------------------------------------------------	-----------------------------------------------------------------------------------------------------------------------------------------------------------------------------------------------------------------------------------------------------------------------------------	---------------------------------------------------------------------------------------------------------------------------------------------------------------------------------------------------------------	----------------------------------------------------------------------------------------------------------------------------------------------------------------------------------------------------------------------------------------------	-----------------------------------------------------------------------------------------------------------------------------------------------------------------------------------------------------------------------------------

3. SPATIAL PRACTICES OF SOUTH ASIAN COMMONALITIES FORMED THROUGH FOOD AND PRAYER WITHIN TOKYO

For prayer venues, Identity is determined by the religion. Space is analyzed by the Year Established, Floor Level, Initiators, Building Status, Street Access, Exterior Façade and Signage. Practice is analyzed by Object, Ritual and Time, Food in Events and Food in Daily Life.

3.3 Spaces and practices of South Asian Commonalities

3.3.1 Commonality of Food: Ethnic Grocery Shops and Restaurants

The shops attract their target customers by signalling their heritage with names with religious connotations or recall important places in their homeland, e.g., the shop “Barahi” in ShinOkubo is named after a Hindu Goddess in Nepal (Figure 4). Similarly, seven shops have the word “Halal” attached, encouraging Muslim visitors. Ethnic grocery shops also differ from typical grocery shops as they are more flexible in appropriating nonconforming spaces. For example, the smallest shop, Sunshine Halal in Ikebukuro, is only 11m², and is above a kebab stall. Baticrom, in the Jujo cluster, is attached to a warehouse and also houses a mosque in its upper story, creating a complex that addresses both food and religious commonalities.

The Practice changes according to the customers. For example, the majority of the shops in the Jujo cluster remain open until 1:00am so that their target customers, Bangladeshi students and workers who return to their home with the last trains, can purchase food. Similarly, shops that are near stations on the Yamanote Line, ShinOkubo and Ikebukuro, took advantage of the higher amount of pedestrian traffic in the highly commercial area and stayed open longer hours. In Okachimachi, the shops kept short operating hours according to their target customers, primarily local South Asian residents. The identity that the grocery shop creates is what attracts the customers. While each shop sold typical South Asian items, there were two other categories: Non-South Asian Items and Religion-related items. The curation of the items sold, which depends on the Owner’s ethnic and religious background, is a method to expand or limit the identity of the space. 18 out of 33 grocery shops sold items that were not South Asian, such as Vietnamese or Thai food items. Observant Hindus do not eat beef and Muslims only partake in Halal meat. None of the Hindu owned shops sold Beef though five out of ten carried other types of Halal meat, expanding their identity from only Hindu to include

3. SPATIAL PRACTICES OF SOUTH ASIAN COMMONALITIES FORMED THROUGH FOOD AND PRAYER WITHIN TOKYO



Fig 3.6 Swagat Bazaar NishiKasai



Fig 3.7 TMVS Foods NishiKasai

3. SPATIAL PRACTICES OF SOUTH ASIAN COMMONALITIES FORMED THROUGH FOOD AND PRAYER WITHIN TOKYO

Muslim customers. Thus, when a shop keeps such items, it shapes its own identity to attract people of different religious and ethnic backgrounds.

In contrast to grocery shops that focus on target customers, restaurants advertise themselves to both the local majority and the minorities, and contribute to the quality of the area through their spatial setting in the urban context. The identity of a restaurant is fixed by the cuisine it serves. Two types of restaurants were identified. One is dedicated to the cuisine of a single country. The other is a fusion of two or more countries. Indian restaurants were the highest, comprising 52 out of the total of 112, and were most concentrated in NishiKasai cluster. Nepalese restaurants were the second highest, 23 out of 112, the greatest concentration found in the ShinOkubo cluster. In the second type, the Nepalese-Indian fusion restaurants were the greatest, 27 out of 112. NishiKasai and ShinOkubo were dominated by Indian and Nepalese restaurants respectively. Okachimachi, Ikebukuro and Jujo showed greater variation in single-country and fusion restaurants. As many South Asians have dietary restrictions due to religion, the practice of the restaurants has an effect in dividing customers. The majority of restaurants had vegetarian options but only 12 South Asian restaurants included halal. The largest concentration of halal restaurants is in the Okachimachi cluster, followed by the Jujo cluster.

3.3.2 Commonality of Religion: Prayer Venues

Out of the ten prayer venues, three were Temples that belong to the Indian religions of Hinduism, Jainism and Sikhism. The remaining are mosques⁽ⁱⁱ⁾ or mosallahs⁽ⁱⁱⁱ⁾, places specific to Islam. Three waves of venue establishment were observed. First, between the years of 1999 and 2003, five prayer venues of three different religions of Jainism, Sikhism and Islam were established. Next, the 2010s saw the opening of the Hindu Temple and the Assalam masjid. Finally, in 2018, only two small mosallahs opened. All of the prayer venues were initiated by local residents, with the exception of the Hindu Temple, which was established by the international organization.

Out of the five owned prayer venues, the mosques had exterior modifications. Two of the three owned mosques had installed domes and added arches to the facades of the buildings, which influences the character of the urban assemblage of the locality (Figure 5). In contrast, the Jain and Hindu temples did not have

3. SPATIAL PRACTICES OF SOUTH ASIAN COMMONALITIES FORMED THROUGH FOOD AND PRAYER WITHIN TOKYO



Fig 3.8 Tokyo Jain temple does not have any facade changes as compared to Assalam mosque, Okachimachi cluster.



Fig 3.9 Assalam mosque, Okachimachi cluster.

3. SPATIAL PRACTICES OF SOUTH ASIAN COMMONALITIES FORMED THROUGH FOOD AND PRAYER WITHIN TOKYO

any modifications on the exterior. While mosques used external modifications to create a connection between the space and identity, the temples used objects within the prayer venue to heighten their connection. The introversion of the Jain temple is indicated by the use of the service door at the back of the building as the primary entrance (Figure 6). All three of the temples brought Sacred and Support Objects from India (Figure 7). There are three different types of spatial practices performed by the venues. First, rituals that are part of each individual religion, such as prayer or recitation of scriptures. The second practice invoke a connection with their home country by bringing objects such as sculptures of deities, symbols, sacred books, cloth and even dishware. The provenance of the objects heightened the connection to the religion and their origin country. The third is the practice of food within the context of religion. For example, the Sikh temple, called a Darbar^(iv), held the communal kitchen called Langar after their weekly congregation, where volunteers prepare food for the worshippers. Similarly, in Otsuka mosque held communal meals on weekends after the evening prayers.

3.2.4 Comparison between the Clusters

Based on Table 1, the clusters could be compared. ShinOkubo and Kamata were compared as they illustrated the absence of Nepalese religious facilities even in areas of high population of Nepalese residents. NishiKasai and Jujo were compared as both showed strong identities, the former for a nationality and the latter for religion. Okachimachi and Ikebukuro were compared as both displayed the influence of a religious space to determine the identity of a cluster and the diversification of ethnic backgrounds.

3.4.1 ShinOkubo and Kamata

In the clusters of ShinOkubo and Kamata, both have a single prayer venue of the mosque, which are rented spaces established by a local multiethnic Muslim community. However, by investigating the demographics of the wards alongside the food commonalities of the grocery shops and restaurants, it is found that there is a large community of Nepalese-Hindu people present but with an absence of a Nepalese-Hindu prayer venue. In interviews with the proprietors of Nepalese-Hindu owned shops, it was established that while in Tokyo, their religion is practiced within the home. This highlights the fact that each religion has its own requirements and

3. SPATIAL PRACTICES OF SOUTH ASIAN COMMONALITIES FORMED THROUGH FOOD AND PRAYER WITHIN TOKYO

the commonalities of food and prayer must be investigated in conjunction with each other in order to fully understand how people of different religious and ethnic backgrounds are utilizing the urban setting. These two clusters also highlight the tendency of Muslim residents to have greater reliance on communal prayer venues and Muslim-owned grocery shops due to their religious practices. In ShinOkubo, there is the second highest Muslim-owned grocery shops alongside the highest number of Nepalese restaurants that do not have halal options. Thus, we can see different approaches in the food and prayer commonalities and the utilization of the city by migrant people may have some overlap but is not uniform.

3.4.2 NishiKasai and Jujo

Contrasting the Nishi Kasai and Jujo cluster, both have a distinct identity through their practices. In NishiKasai, the grocery shops emphasize the national Indian identity by limiting the items sold to only Indian / South Asian items with no focus on halal meat and adjust their operating hours specifically to the Indian IT community that lives in this area. At the same time, the highest number of Indian cuisine restaurants in all the clusters are found in this area. Furthermore, the international Hindu organization of ISKON opened its doors specifically in this area as it is famous for its Indian population. Collectively, these factors indicate a strong Indian national identity in the cluster that is reinforced by the operators of the grocery shops, restaurants and prayer venue. On the other hand, the Jujo cluster emphasizes a religious identity of the resident Muslims. Grocery shops in Jujo sell non-South Asians items with an emphasis on the availability of halal items and halal meat, which are required by the Muslim residents. This practice broadens the type of visitor they attract, such as other Asian ethnicities in addition to non-South Asians Muslim communities of Arab, Turks or Kazakhs. The increase of Bangladeshi Muslim owned shops in the past five years is most evident in the Jujo cluster, three out of the seven opening in 2018. The second highest number of restaurants with halal options were also found in this area. Additionally, unlike the Hindu Temple of NishiKasai, the prayer venues found in the Jujo cluster have been opened by

3. SPATIAL PRACTICES OF SOUTH ASIAN COMMONALITIES FORMED THROUGH FOOD AND PRAYER WITHIN TOKYO



Fig 3.10 A halal grocery store that offers bento closed during the day, Jujo cluster



Fig 3.11 A Hindu Indian restaurant that prepares food according to vegetarian standards in NishiKasai cluster

3. SPATIAL PRACTICES OF SOUTH ASIAN COMMONALITIES FORMED THROUGH FOOD AND PRAYER WITHIN TOKYO

local volunteers. Thus, the food and religious commonalities have exerted a strong influence of the urban character of the areas.

3.4.3 Okachimachi and Ikebukuro

In the Okachimachi and Ikebukuro clusters, religious facilities and the diversification of facilities over time becomes apparent. In Okachimachi, there is one Jain temple and one mosque. Initially, there was a strong Indian character in the cluster, as the temple was established by a group of local Indian residents and the shops which opened were also Indian. The diversification of ethnic and religious backgrounds becomes apparent as the Assalam mosque was established by Sri Lankan Muslims in 2010 and the most recent grocery shops are opened by Bangladeshi Muslims, indicating people who need and visit these facilities. Similarly, in Ikebukuro there are two different prayer venues: the Tokyo Sikh Darbar and the Otsuka mosque. The proprietor of the first shop in this cluster took part in establishing the mosque. Though both prayer venues were established at the same time, the population of Sikh people remains relatively small in comparison to the users of the mosque. The diversity of ethnic as well as religious background is seen by the increase in Nepalese Buddhist and Hindu owned shops, followed by Muslim owned shops. Though no Sikh owned grocery shop was found in the cluster, it was determined during the interviews with the volunteers of the Darbar that they order food items directly to the prayer venue from Indian Hindu businesses. Thus, the clusters of Okachimachi and Ikebukuro illustrate the dynamic interdependence of the commonalities of religion and food

3. SPATIAL PRACTICES OF SOUTH ASIAN COMMONALITIES FORMED THROUGH FOOD AND PRAYER WITHIN TOKYO

and the gradual diversification in the ethnicities of people utilizing an urban area over time.

3.5 Conclusion

Commonalities of food and prayer can be shared by people of different ethnicities, and are found in the facilities of grocery shops, restaurants and prayer venues. In Tokyo, a relationship in the concentration of the facilities and the train stations was determined and is termed as a “cluster”. Six clusters of NishiKasai, Okachimachi, Ikebukuro, ShinOkubo, Kamata and Jujo were found. The spatial practices of the facilities were clarified, which articulate their identity and, in turn, affect the urban character of the cluster. Through comparisons, the evolution of the urban character of the clusters is made evident. In Shin Okubo and Kamata, it is shown that the religious and food commonalities must be studied together for a more accurate indication of the diversity of people residing in the area. Comparing NishiKasai and Jujo, the former developed an Indian nationality-oriented identity while the latter a Muslim religion-oriented identity. A comparison of Okachimachi and Ikebukuro demonstrated how a group of people contribute to their diversification by attracting people of similar ethnicities by the practices of the facilities. Thus, the diversity of people within Tokyo is made evident by the investigating the spatial practices of the everyday facilities of grocery stores, restaurants and prayer venues of the different South Asian ethnicities, which enable the commonalities of food and prayer to exist within the city.

3. SPATIAL PRACTICES OF SOUTH ASIAN COMMONALITIES FORMED THROUGH FOOD AND PRAYER WITHIN TOKYO

References

1. Sassen, S: *The Global City: New York, London, Tokyo*. Princeton, N.J.: Princeton University Press, 2001.
2. “Demographic Shift Sees Japan’s Foreign Population Rise to 2.25%” <https://www.nippon.com/en/japan-data/h00791/>. Aug 18, 2020
3. “Japan’s new skilled worker visa program still far behind goal”. <https://www.japantimes.co.jp/news/2020/08/30/national/japan-new-skilled-worker-visa-program>. Aug 30, 2020
4. *Kooperatives Labor Studierender + Atelier Bow-Wow: Urban Forest*. Spector Books. 2016
5. Komai, H: *Migrants in Japan*: Trans Pacific Press. 1999
6. Ahmed, I: *The Construction of Diaspora: South Asians living in Japan*. The University Press Limited, 2000
7. Azuma, M: *Indians in Tokyo and its vicinity*. In *Rising India and Indian Communities in East Asia*, ISEAS Publishing, 2008
8. Sawa M: *Spatial Reorganisation of the Indian Community Crossing Border: A Case Study of the Global City Tokyo*. *Japanese Journal of Human Geography*, Vol.65 Issue 6 Pages 508-526. 2013
9. Kitahara R, Otsuki T: *A study on the living environment of Bangladeshi foreign residents in Kita-ku, Tokyo: Influence on the concentrated area in a receiving country of migrant workers from chain migration based on international labor movement*. *Jpn Archit Rev*. 2018;00:1–14. <https://doi.org/10.1002/2475-8876.12029>
10. Lefebvre H.: *The Production of Space*, translated by Donald Nicholson-Smith, Blackwell Publishers, 1991
11. Certeau, M: *The Practice of Everyday Life*. University of California Press, 1984
12. Sloterdijk, P: *Spheres.3:Foams: plural spherology*. Semiotext(e). 2016
13. Green, David. “As Its Population Ages, Japan Quietly Turns to Immigration” *Migration Policy Institute*. <https://www.migrationpolicy.org/article/its-population-ages-japan-quietly-turns-immigration>. March 28,2017
14. Flowers, Petrice R. “From Kokusaika To Tabunka Kyōsei: Global Norms, Discourses of Difference, and Multiculturalism in Japan.” *Critical Asian Studies*, vol. 44, no. 4, 2012, pp. 515–42

Notes:

- (i) Halal - Food prepared according to Islamic religious principles
- (ii) Mosque - A permanent prayer space for Muslims
- (iii) Mosallah - A temporary prayer space for Muslims
- (iv) Darbar - Literal meaning of “Court”. In Sikhism, the holy scripture is considered the guru and each location which houses the scripture is called the Darbar. In Tokyo, the actual scripture is kept at a volunteer’s house and is used only on important days.
- (v) Jain vegetarianism differs from typical vegetarianism

4. CONTENT SPATIAL PRACTICES REINTERPRETING A STREET INTO A HANRYU SHOTENGAI

内容 空間実践 路上を韓流商店街に再解釈する

Abstract

This study examines the appropriation of the street by content through field surveys on the spatial practices of Korean pop-cultural content facilities of restaurants, merchandise, clothing and skincare shops, which are popular due to Hanryu media influence. A street in ShinOkubo, an area with a history of Korean presence and responding to the “expectation” of Hanryu for the visitor, was analyzed according to the factors of content space and the physical setting of the setback, which together form the encounter zone that is divided into three layers of: the street curb, the shop façade, and the in-between. Different appropriation elements were utilized according to the practices of the different content facilities and appeared in six patterns in the encounter zone, facilitating the “participation” of the visitors. Consequent of the appropriation elements, the street characteristics of: overloaded edge, which shows the street curb used to force encounter between visitor and content; thickened threshold, showing the habitable layer developed between public street and private interior; horizontal agglomeration, solidifying the identity of the street, were clarified.

4.1 Introduction

ShinOkubo is a place of mediation. Inaba Yoshiko, in her work titled “the Power of Okubo”, describes it as a place of “fuzzy boundaries”, where the “outsider” brings and applies their own forms of knowledge in the practical use of urban space¹. As part of Shinjuku ward, which has the highest degree of cultural diversity within the Tokyo metropolitan area, ShinOkubo’s identity is deeply tied with the people of the Korean community that have made that area a place of residence, work and leisure.

Relations between Japan and Korean have had their fair share of tension, coming from Japan’s colonial past and the subsequent racial discrimination faced by the Korean residents of the country, yet there has been a constant exchange of ideas and culture. An example of this is “Hanryu”, the global phenomenon of an appreciation for Korean pop-culture that has taken hold in Japan as well as many other countries.

4.1.2 Hanryu as an open commonality

Hanryu can be considered as an example of an “open” commonality, which reaches out to people of all ages and genders to partake in it. An open commonality does not involve canons of religious practic-

4. CONTENT SPATIAL PRACTICES REINTERPRETING A STREET INTO A HANRYU SHOTENGAI

es, which are limited to members of the religion and should not be replicated without a basic understanding of the dogma. Semi-open commonalities, such as traditional food of a particular region, is rooted in culture but does actively reach out for new members, being principally for members of the community and for people who actively seek it out. Open commonalities on the other hand actively reach out for new members and has an example in the production of “soft power” that shapes the preference and appeal by exporting cultural products tied to their location of origin, in this case Korea, yet also being easily consumable by people around the world.

The soft power of Hanryu has unmistakably taken hold in the cultural consciousness in Japan. It encompasses pop-cultural products such as music, movies, tv series as well as products such as skincare, beauty and fashion. First beginning in 2003 with the TV series of “Winter’s Sonata”, middle-aged women were a strong force in increasing its popularity and success in Japan². Japan is currently in the fourth wave of Hanryu with the rise of bands such as BTS and the TV series of “Crash Landing on You”. Social media is a major contributor to the popularity of such cultural products, especially as the world experiences a global pandemic where people are forced indoors and are looking for new methods of entertainment. Beauty and clothing also become factors to contend with in this cultural space. K-pop idols and actors promote the use of skin care



Fig 4.1 Korean Drama - Winter's Sonata, 2002



Fig 4.2 Korean Drama - Crash Landing on You, 2020

4. CONTENT SPATIAL PRACTICES REINTERPRETING A STREET INTO A HANRYU SHOTENGAI

and beauty products and their fans, in a show of solidarity with their favourites, use their purchasing power to consume promoted products. Thus, open commonalities are intertwined with global economics as well as culture.

Hanryu provides a sphere of fantasy³ where modern life can be conducted and the reality of international strained relations can be gracefully sidestepped⁴. Yet, this phenomenon has climbed out of the realm of social media and into the material realm of the urban space. ShinOkubo, with its long history of Korean activity, becomes the best place to light a match for the production urban Hanryu spaces⁵.

A second reason ShinOkubo becomes an area of interest is that the gradient of commonalities at work in the urban context is most apparent here. There are a number of temples and churches as well as a mosallah in the area, signifying the presence of closed commonalities. There is “Islam-yokocho”, which is used to refer to a cluster of halal and South Asian shops on the west side of ShinOkubo station, considered as an example of semi-open commonalities. ShinOkubo also contains the subject of this chapter’s focus, a street colloquially known as Ikemen street.

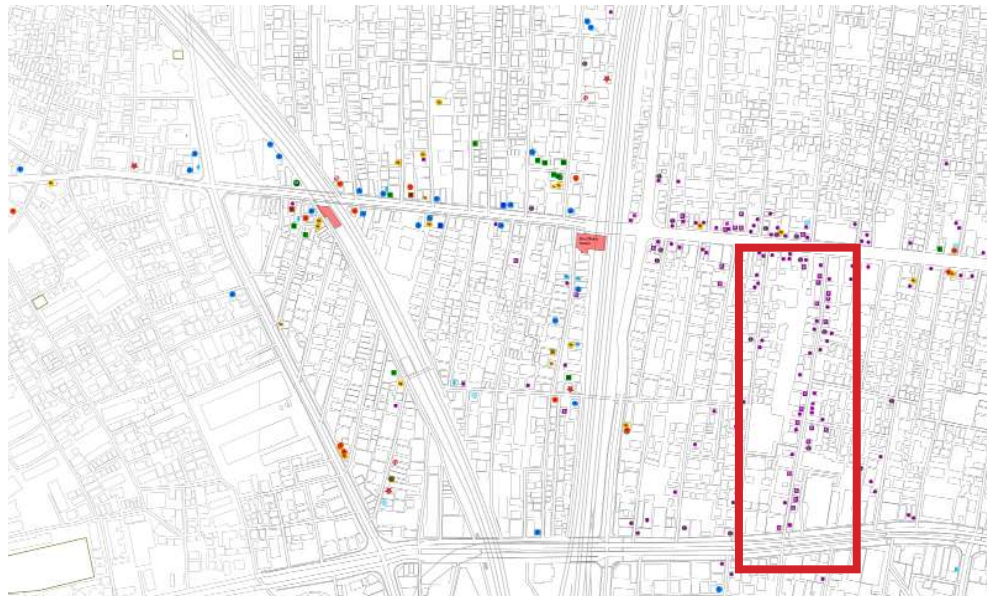

Fig 4.3 Ethnic facilities found in ShinOkubo area

4.1.3 Definition of Content Space

In previous studies, content space has been analyzed within the framework of “dividual” spaces that provide a domestic quality in an urban setting to the user on an interior scale⁶. The collection of such “domestic” spaces within generic, tall zakkyo buildings lead to the production of content space on a building scale. The content space was characterized as being (i) immersive, (ii) convenient, and (iii) multiple choice. Content space was concluded to be generic building-containers where the desired exchangeable products of the content superseded architectural distinction. The quality of liminality, of thresholds, was discussed in the context of urban content space, where the discipline of daily life is relaxed to enjoy the pursued content.

4.1.4 Aim of Study

In this study, the framework to discuss urban content space is expanded by investigating it through the perspective of open migrant commonalities. The contents do not remain in the neutral building-container and spread out onto the public street, leading to a collective consumption of contents. The ephemeral fantasy provided by social media activities of the contents is layered onto the urban physical space. The aim of this thesis is to clarify the spatial practices of the contents to appropriate the urban threshold space of the setback, which lies between the interior and the public realm.

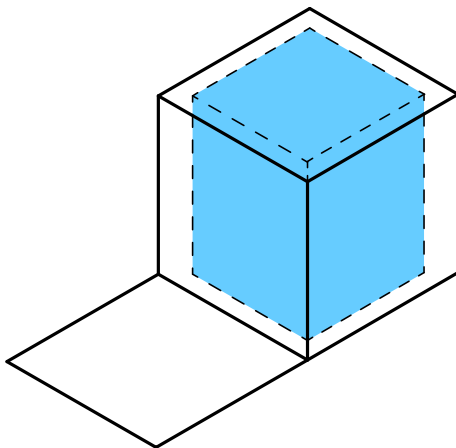

Fig 4.4a Domestic scale interior content space

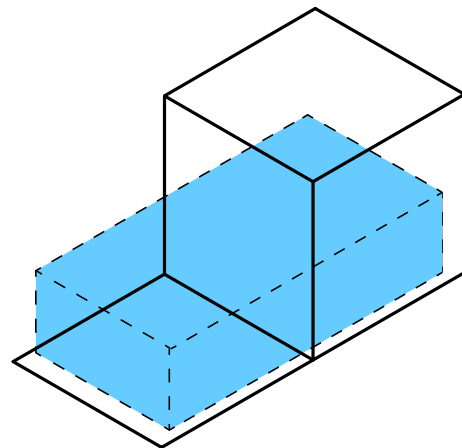

Fig 4.4b. Extroverted content space

4.2 Methodology

This thesis focuses on one particular street known as “Ikemen street”, perpendicular to main Okubo-dori and connecting it with Syokuan-dori. The street came to be known by its unusual name due to the large number of Korean restaurants that have agglomerated along it. Usually such restaurants would have male staff members advertising their menu standing in front of the shop in the street. Capitalizing on this intriguing nomenclature, many restaurants and shops have adopted it as their official location.

4.2.1 Parameters of Examined Content and the Physical Setting

The first step of the methodology is to define the contents related to Korean pop culture present and the physical parameters of Ikemen street.

Ikemen street is 326m long and has a varying width between 4m and 2.5m. 27 restaurants, including two cafes and a dessert stand, 12 Korean cosmetics-skincare shops, six Korean fashion shops, and finally five K-pop idol merchandise shops were recorded on Ikemen street (Fig 2).

The appropriating practices of the content on the physical setting both reimagine Ikemen-dori into a Hanryu Shotengai.

4. CONTENT SPATIAL PRACTICES REINTERPRETING A STREET INTO A HANRYU SHOTENGAI



Fig 4.5 Changes in Width - Ikemen dori, ShinOkubo

4. CONTENT SPATIAL PRACTICES REINTERPRETING A STREET INTO A HANRYU SHOTENGAI

Table 4.1 Contents found in Ikemen dori

No.	Name	Total Building				Content		
		Const.	Type	Flrs	Area (m ²)	Flr	Area (m ²)	Service
1	Ton-chang	RC	Independent	3	316	3	316	Restaurant
2	宋家カムジャタン 別館	RC	Mixed-use	5	650	GF	98.4	Restaurant
3	カントンの思い出	RC	Mixed-use	3	194	GF	166	Restaurant
4	Soju Hanzan	RC	Mixed-use	3	144	GF	128	Restaurant
5a	HANAM PIG	RC	Independent	2	160	GF	59	Restaurant
5b	Seoul Café	RC	Independent	2	160	2F	59	Cafe
6	Uncle Joe's		Food truck		80	GF	80	Cafe
7a	Jongno Hotok	RC	Mixed-use	3	160	GF		Hotdog stand
7b	Itarō	RC	Mixed-use	3	160	GF	179	Restaurant
8a	カントンの思い出 029店	RC	Mixed-use	5	319	GF	62	Restaurant
8b	マニト	RC	Mixed-use	5	319	GF	62	Restaurant
8c	ドヤジ屋	RC	Mixed-use	5	319	GF	62	Restaurant
8d	Chuo Sigean	RC	Mixed-use	5	319	GF	62	Restaurant
9	Factory 45	RC	Mixed-use	5		2F	175	Restaurant
10	Over macron	RC	Mixed-use	3	135	GF		Dessert stand
11	豚マダン	RC	Mixed-use	4	158	GF	25	Restaurant
12	マッコリの物語	RC	Mixed-use	3	160	GF	109	Restaurant
13	75chacha	RC	Independent	2	48	GF	48	Restaurant
14	Seoul Tiramisu	Wd	Independent	3	49	GF	5.4	Dessert stand
15	コルモク食堂	Wd	Independent	2	44	GF	28	Restaurant
16	ヨブの王豚塩焼	Wd	Independent	3	165	GF	86	Restaurant
17	Kantom JMT	RC	Independent	2	200	GF	181	Restaurant
18	Moise	RC	Mixed-use	3	250	GF	17	Restaurant
19	KollaBo	RC	Mixed-use	3	250	GF	99	Restaurant
20	青松 新	RC	Mixed-use	4	150	2F	37	Restaurant
21	韓マウン	RC	Mixed-use	2	111	GF	71	Restaurant
22	Dongnara	RC	Mixed-use	8	573	GF	36	Restaurant
32	She'z Cosme	Wd	Rowhouse	2	121	GF	33	Cosmetics
2c	Popskin	RC	Mixed-use	5	650	GF	35	Cosmetics
33	Skinholic - big one	Ss	Independent	1	212	GF	212	Cosmetics
34	美&私	RC	Mixed-use	3	144	GF	21	Cosmetics
35a	Gallery45	RC	Mixed-use	5	198	GF	49	Cosmetics
35b	Unique sense	RC	Mixed-use	5	198	GF	49	Cosmetics
36	Starbox	Temp	Independent	1	45	GF	45	Cosmetics
37a	スマイルコスメ	RC	Mixed-use	4	150	GF	24	Cosmetics
37b	キムズコスメ	RC	Mixed-use	4	150	GF	24	Cosmetics
37c	Onnine	RC	Mixed-use	4	150	GF	24	Cosmetics
38	BN the shiny	RC	Mixed-use	3	160	GF	24	Cosmetics
39	美肌工房 自然の森	Ss	Independent	2	46	GF	46	Cosmetics
28	HANA	Wd	Rowhouse	2	74	GF	14	Fashion
29	Fashion sense	Wd	Rowhouse	2	121	GF	33	Fashion
2b	Plac Shoes by Placebo	RC	Mixed-use	5	650	GF	35	Fashion
2c	Nailparty	RC	Mixed-use	5	650	GF	35	Fashion
30	LaBelle	Wd	Independent	3	42	GF	26	Fashion
31	U&美	RC	Mixed-use	4	250	GF	15	Fashion
23	Happy Days	Wd	Rowhouse	2	104	GF	33	Merchandise
24	Noranekeo	Wd	Rowhouse	2	104	GF	33	Merchandise
25	Moiza	Wd	Independent	2	136	GF	86	Merchandise
26	Magic shop	Temp	Temporary	1	34	GF	32	Merchandise
27	Korea shop	RC	Mixed-use	3	135	GF	65	Merchandise

4. CONTENT SPATIAL PRACTICES REINTERPRETING A STREET INTO A HANRYU SHOTENGAI

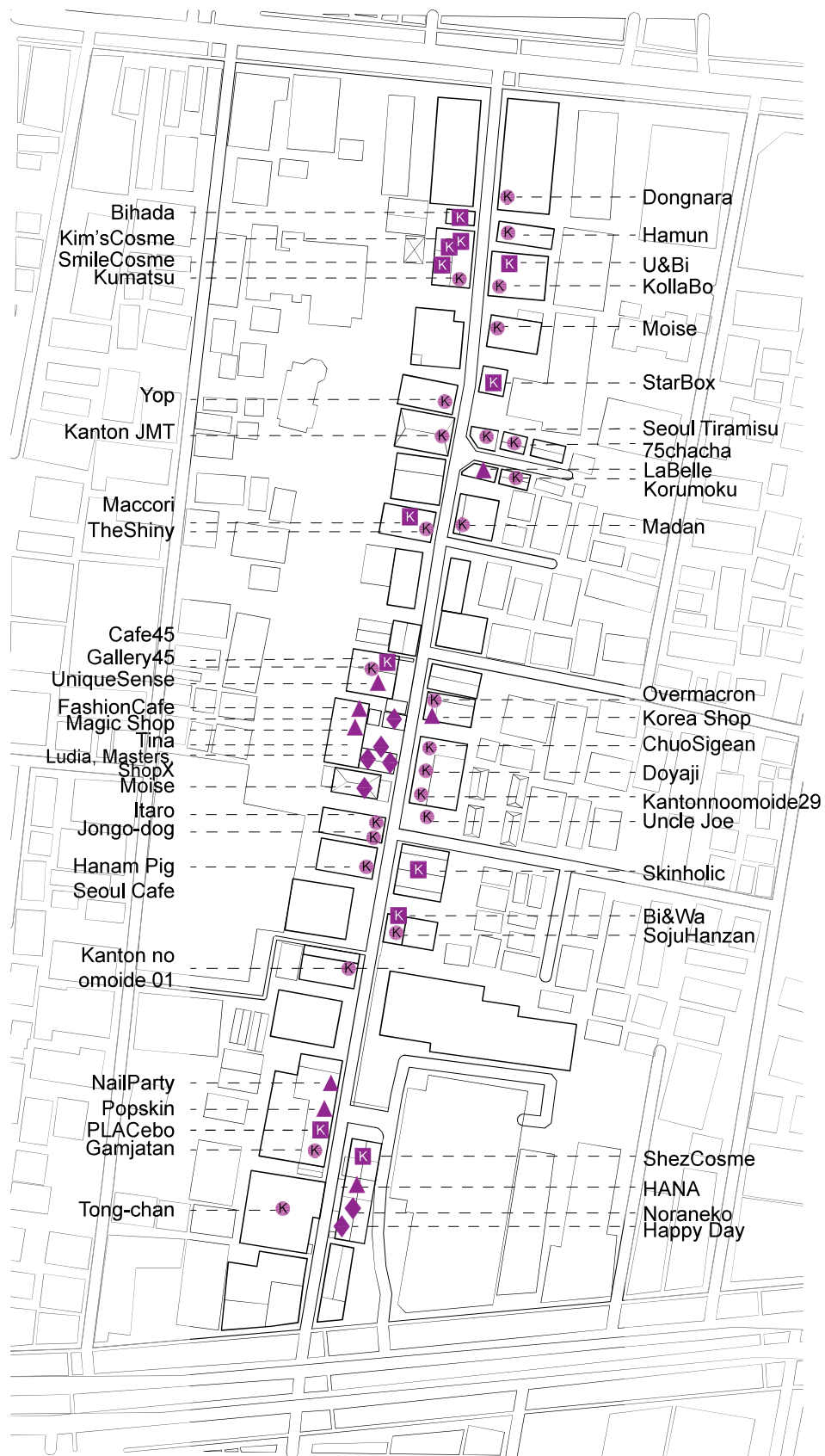

Fig 4.6 Content Space - Ikemen dori

4.2.2 The “Threshold” of the Setback

The setback is the threshold between the commercial interior space and the public street. Therefore, it can be lawfully appropriated by the proprietors of the shop or restaurant to create an encounter with their content. However, there are certain unchangeable physical aspects to the setback.

a) Setback shape

The setback between the facade of the building and the curb of the street becomes an important element in itself. It becomes the main zone of encounters. People walking along Ikemen dori will look around, stroll, stop to handle merchandise and read menus. The practices of the appropriation respond to such behaviours. Thus, these two factors become inextricably linked. The setback is divided into the following categories (Fig. 6), depending on its spatial parameters.

- i) Setback: This is the traditional setback between the building structure and the edge of the road.
- ii) Setback gap: In this situation, the shop or restaurant is able to appropriate the gap space, also connected to Ikemen dori, between itself and the adjoining building.
- iii) Setback Corner: In this situation, the building occupies a corner plot, with the front on Ikemen dori.
- iv) Cul-de-sac: A cul-de-sac is formed by a blind street connected to Ikemen dori and enclosed by buildings.

4. CONTENT SPATIAL PRACTICES REINTERPRETING A STREET INTO A HANRYU SHOTENGAI

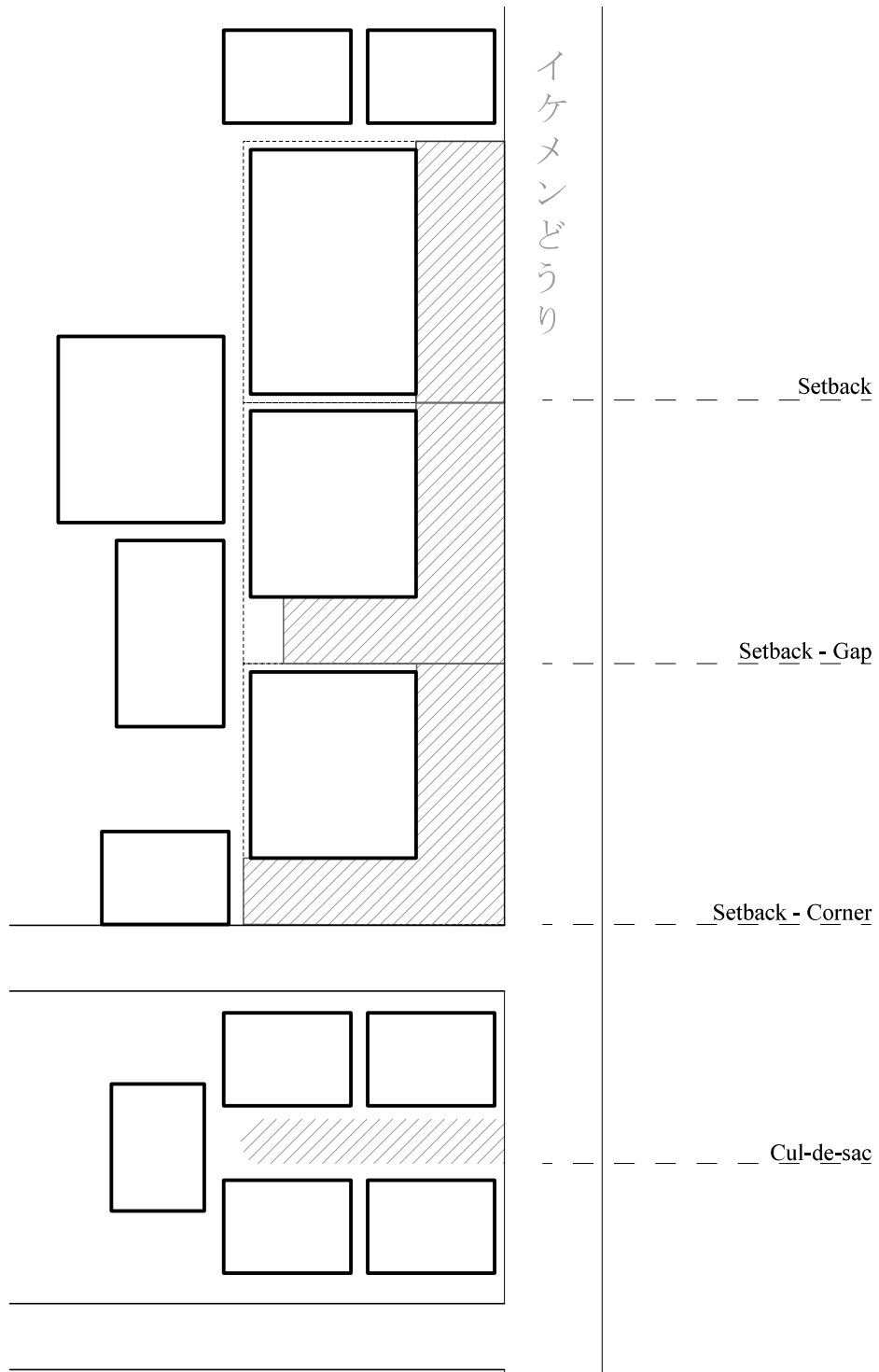

Fig 4.7 Setback shapes - Ikemen dori

4. CONTENT SPATIAL PRACTICES REINTERPRETING A STREET INTO A HANRYU SHOTENGAI

c) Setback Dimensions- Depth x Width

The depth and width of the setback is an integral factor in the methods in which it is appropriated and varies from shallow to deep. The setback is inherently connective, in parallel and across the street.

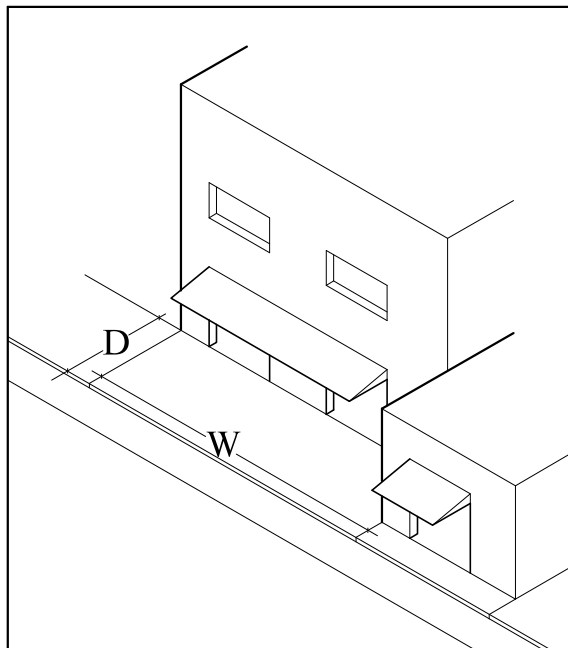

Fig 4.8 Setback depth and width

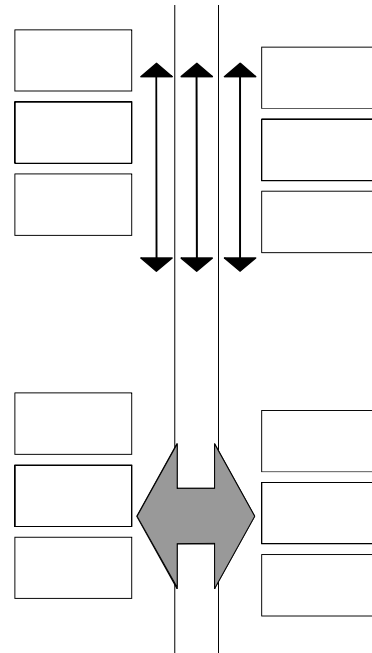

Fig 4.9 Connectivity of the Setback

c) Overhead condition

The overhead condition has three possibilities. It is either free, leaving a space for an awning to be attached; or has eaves (Ev) extending over the setback; or has a projection, such as a balcony, above it.

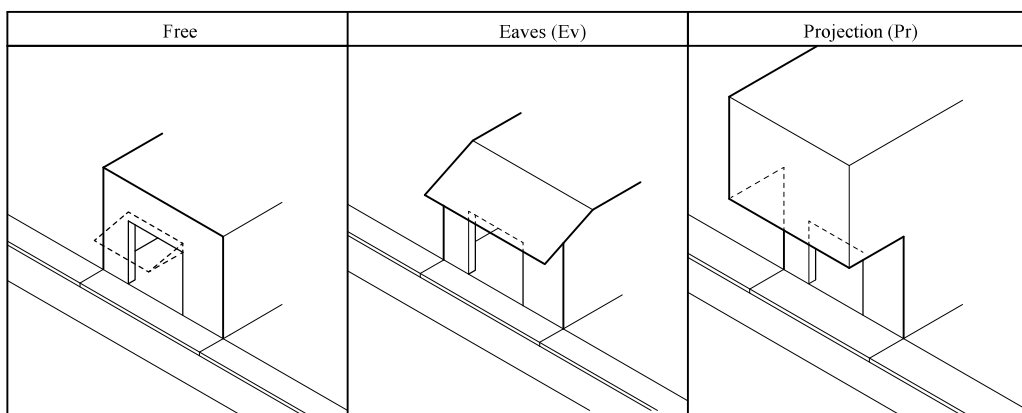

Fig 4.10 Overhead conditions of the Setback

4.2.3 Content Space and its Appropriation Elements

Each of the facilities of the Hanryu content rely on appropriation elements to create an encounter between itself and the visitor. The appropriation element differs according to the content. Some of the appropriation elements are specific, while others are shared Table 4.2.

(i) Restaurants

In restaurants, the finished product is that of prepared cuisine, which is offered to the patrons within the interior space. Thus, restaurants rely on appropriation elements such as Menu stands [Ms], [Mm]; posters [Po]; Banners [Bn] as well as display fridges [Df] to create an encounter between visitor and the Hanryu content, as seen in Table 4.2

(ii) Skincare shops

In skincare shops, the finished product itself is used by using appropriation elements such as Display units [Du], [Ds]; standing units [Su]; trolleys [Tr]; and shelving units [Sh], refer to Table 4.2 for full list.

(iii) Clothing shops

In clothing shops, appropriation elements such as clothing rails [Cr]; Hanging frames [Hf] and others, as seen in Table 4.2, are used

(iv) Merchandise shops

In merchandise shops, appropriation elements such as posters [Po]; cutouts [Co], display units [Du], and others as seen in Table 4.2

(v) Shared Appropriation Elements

As seen in Table 4.2, the restaurants and different shop contents use some appropriation elements that are similar, such as awnings [Aw], Game machines [Gm], etc.

4. CONTENT SPATIAL PRACTICES REINTERPRETING A STREET INTO A HANRYU SHOTENGAI

Table 4.2 Appropriation Elements of Contents

Restaurants	
Element	Tag
Ashtry stand	As
Awning	Aw
Banner advertisement	Bn
Beer crates	Be
Counter	Ce
Curtain	Cn
Cutouts	Co
Display fridge	Df
Game machines	Gm
Grocery shelf	Gr
Menu stand - Large	Ms
Menu stand - small	Mm
Menu- folding	Mf
Mat	Ma
Posters	Po
Seating	Se
Storage boxes	Sg
Sound system	Ssy
Table	Tb
Takeaway window	Tkw
Tent	Tt
Tv monitor	Tv
Faux food	Fx
Umbrella	Um

Shops	
Element	Tag
Awning	Aw
Banner advertisement	Bn
Carton	Ct
Clothing rail	Cr
Curtain	Cn
Cutouts	Co
Display unit - large	Du
Display unit - small	Ds
Game machines	Gm
Hanging frame	Hf
Tv monitor	Tv
Trolley	Tr
Standing units	Su
Shelving unit	Sh
Mat	Ma
Posters	Po
Umbrella	Um

4. CONTENT SPATIAL PRACTICES REINTERPRETING A STREET INTO A HANRYU SHOTENGAI





Menu stand - large (Ms)	Menu stand - folding (Mf)	Menu stand - small (Mm)
		
Display fridge (Df)	Ashtray stand (As)	Seating (Se)
		
Banner ad (Bn)	Posters (Po)	Curtain (Cn)
		
Mat (Ma)	Beer crates (Be)	Storage boxes (Sg)
		
Tv Monitor (Tv)	Tent (Tt)	Umbrella (Um)
		

Fig 4.11 Examples of elements found in restaurants

4. CONTENT SPATIAL PRACTICES REINTERPRETING A STREET INTO A HANRYU SHOTENGAI

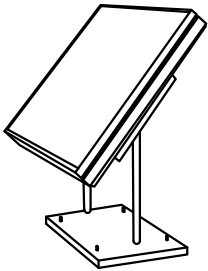
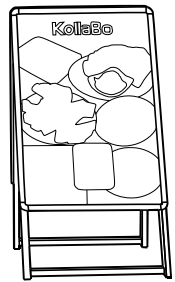
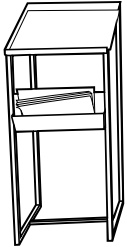
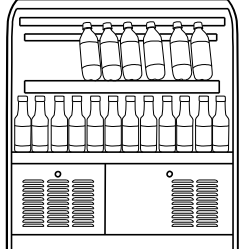
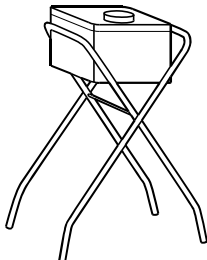
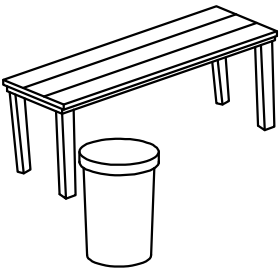
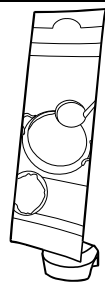
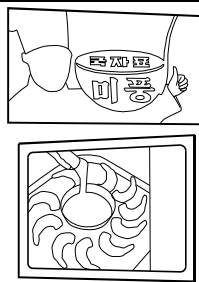
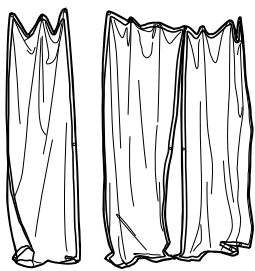
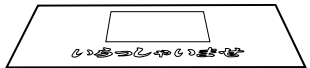
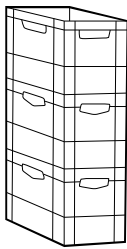
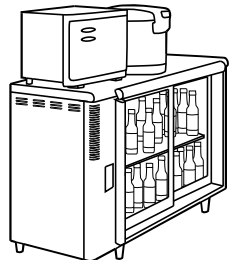

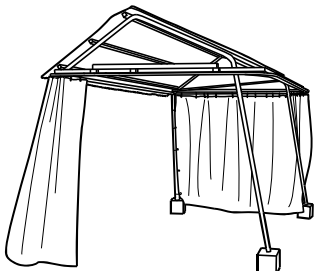

Display unit - large (Du)	Display unit - small (Ds)	Standing unit (Su)
		
Shelving unit (Sh)	Hanging frame (Hf)	Table (Tb)
		
Trolley (Tr)	Clothing rail (Cr)	Game machine (Gm)
		
Mat (Ma)	Umbrella (Um)	Cutouts (Co)
		
TV and audio (Tv)	Posters (Po)	Simple stand (Sd)
		

Fig 4.12 Examples of elements found in shops

4.3 Encounter Zone - Behaviour and Physical setting

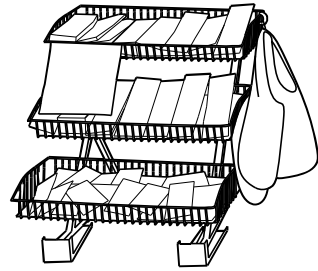
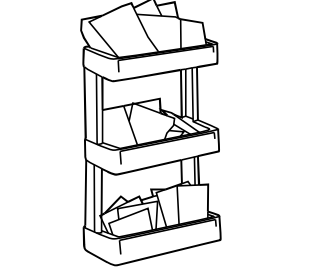
Technically, any appropriating element can be placed at any point on the setback. However, it is the combination of behaviours and the availability of the physical space that starts controlling the positioning of the elements. The visitors encounter the appropriation element in layers on the setback, beginning from the street curb until they reach the interior.

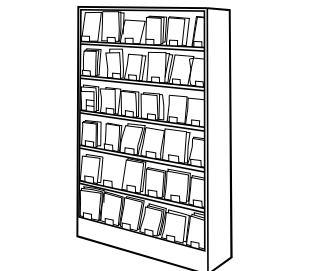
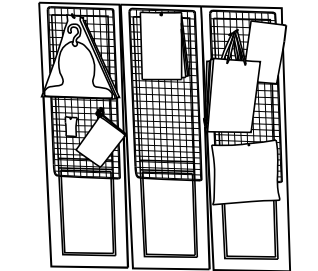
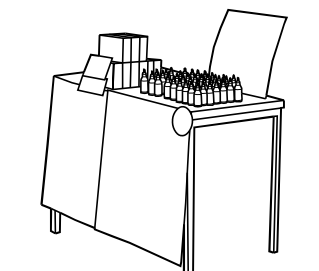
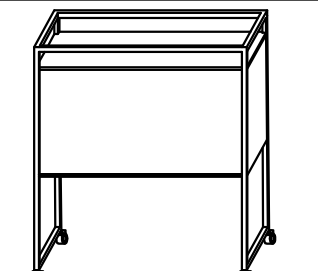
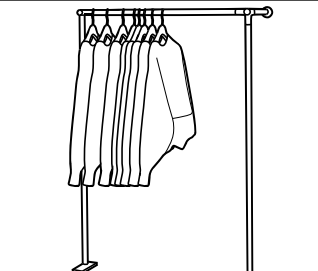
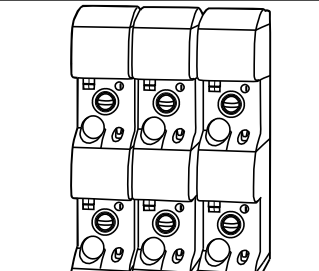
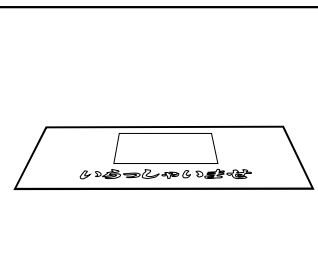
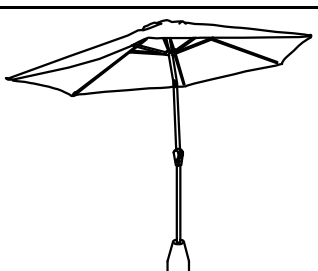
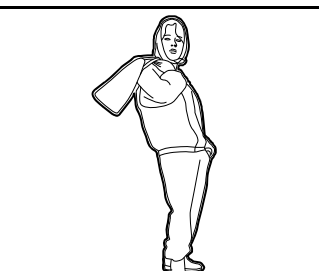
E0 : Before the first encounter in the physical urban reality occurs, there is the of the Hanryu phenomenon. The visitors come to this street with the expectation of encountering Hanryu content. The appropriation elements facilitate the participation in the consumption of the content.

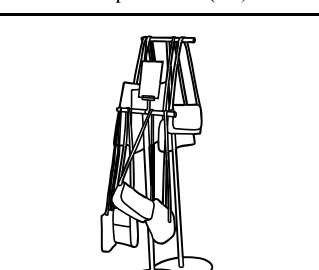
E1: In the layer E1, visitors start encountering the appropriation elements. This may be in the form of menu stands in the case of restaurants, or display units or trolleys.

E2: In the layer of E2, the appropriation elements form a habitable layer where the visitors spend time on the setback. In the case of restaurant, it may be seating or tables. In the case of shops, hanging frames, display units with umbrellas are used, or they stopped to stay in the setback area by the takeout window [Tk].

E3: In the layer of E3, the visitors either enter into the interior through the door [Dr] or opening [Op], therefore leaving the setback.

4. CONTENT SPATIAL PRACTICES REINTERPRETING A STREET INTO A HANRYU SHOTENGAI

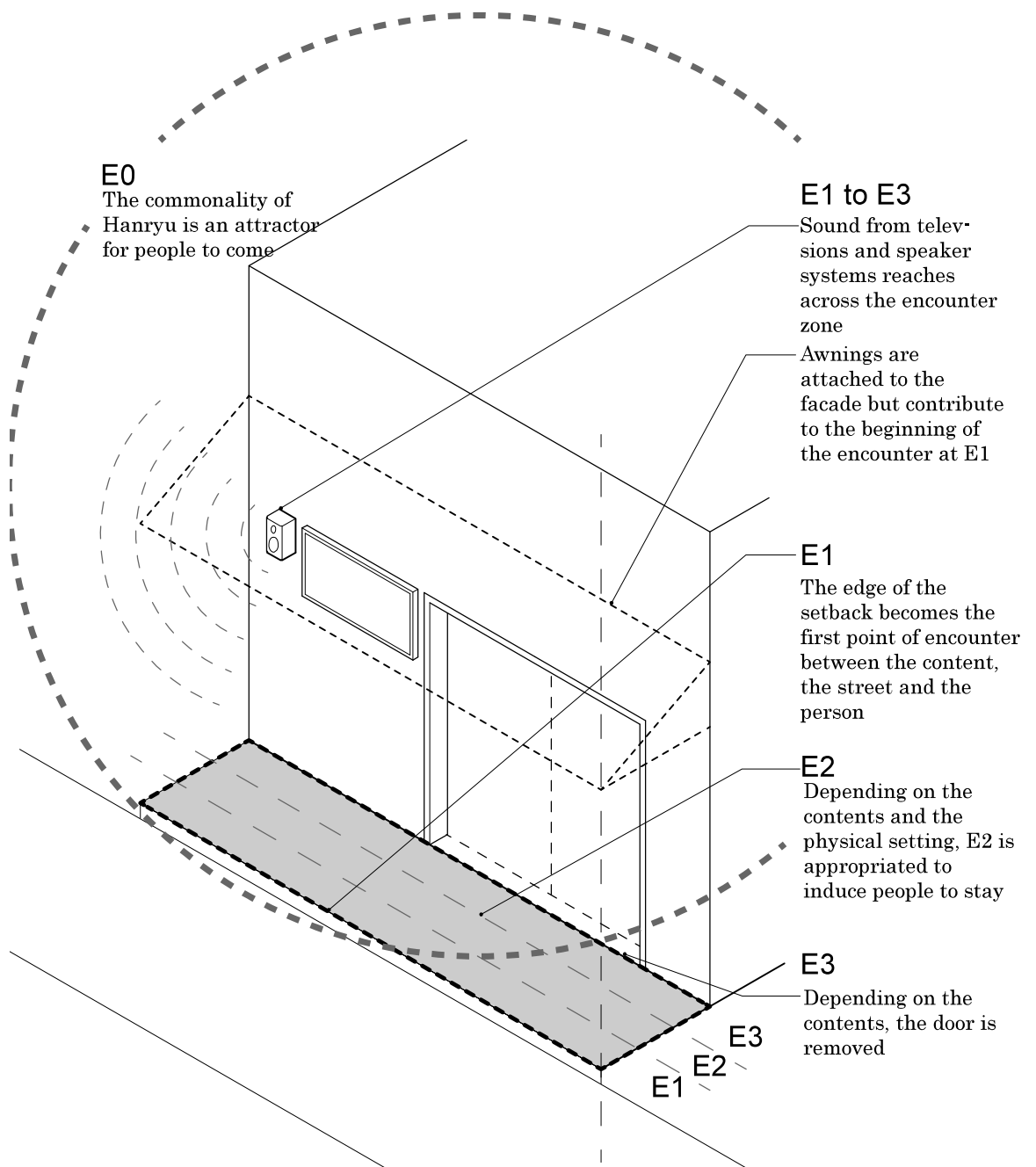

Fig 4.13 Encounter zone on the setback

4. CONTENT SPATIAL PRACTICES REINTERPRETING A STREET INTO A HANRYU SHOTENGAI



Fig 4.14 Encounter zone at Ikemen dori

4. CONTENT SPATIAL PRACTICES REINTERPRETING A STREET INTO A HANRYU SHOTENGAI

Table 4.3 Encounter Patterns of the Appropriation Tendencies

No.	Name	Physical Setting					Cont ents	Appropriation Tendencies in Encounter			Encounter Pattern
		Setback			Const	Over head		E1	E2	E3	
		Shape	Depth	Width (Bldg)							
33b	Noraneke	Setback	2.2	3.5 (19)	Wd	x	Mr	Dr			E1
10a	Jongno Hottok	Setback	1	2.5 (8)	RC			Aw,Po	Tkw		
18	Overmacron	Setback	1.5	3 (7)	RC	Pr	Rs	Bn,Tb,Tv	Df, Tkw		E1E2
6	Uncle Joe's	Setback-side	4.5	8	Tmp			Aw, Ma,Bn,Fx,Tv, Cu	Tb,Se,Sg,Um,Tt,Tkw		
40a	Hana	Setback	2.2	8 (18)	Wd		Fs	Aw, Po	Tb,Ce,Hf		
29	韓マウン2F	Setback	2	1.5	RC	Pr		Ma,Tv		Str	
26	Moise	Setback	1	3.8 (10)	RC	x		Ms,Mf,Ma,Po,Bn		Dr	
27c	青松新	Setback	1	2 (14)	RC	Pr		Mf,Po,Tv		Dr	
28	KollaBo	Setback	1.2	3.8 (10)	RC	x	Rs	Ms,Mf,Ma,Po, Fx		Dr	
23	コルモク	Cul-de-sac	1	9.6	Wd	x		Ms		Dr	
8a	Seoul Café 2F	Setback	2	2.5(8)	RC	x		Po		Str	E1E3
17a	Factory 45-2F	Setback	5.5	1.3 (12)	RC	Pr		Ms,Mm,Mf		Str	
40b	Fashion Sense	Setback	1	3.3 (12)	Wd		Fs	Aw		Dr	
7b	美&知	Setback	1.2	2.3 (9)	RC			Aw,Du,Ma		Op	
27a	スマイルコスメ	Setback	1.3	2 (14)	RC	Pr	Co	Hf		Op	
40c	ShezCosme	Setback	2	3.3 (12)	Wd			Aw,Tr		Dr	
35	Moiza	Setback	1.2	7	Wd	Ev	Mr		TrGm	Dr	E2E3
17b	Gallery45	Setback	5.5	5.4 (12)	RC	x	Co		Aw,Tr,Du, Um	Op	
6	カントンの思い出	Setback	1.7	2.9 (8.7)	RC			Aw,Ms,Mm,Ma	Sg	Dr	
7a	Soju Hanzan	Setback	1.2	5.4 (9)	RC	x		Ms,Mm,Po, Tv	Se	Dr	
10b	Itaro	Setback	1	5.8 (8)	RC	Pr		Ms,Mm,Ma,Po	Gr,Ssy	Dr	
19	豚マダン	Setback	1.6	12	RC	x		Po,Cn	Ce,Tb,Se, Tkw	Dr	
20	マッコリの物語	Setback	1.3	4 (9)	RC	Ev		Ms,Mm,Ma,Bn	As,Sg	Dr	
2	Tong-chan	Setback	2	19	RC			Aw,Ms,Po	Tb,Se, Tkw	Dr	
8b	HanamPig	Setback	2	5.4 (8)	RC	Pr		Ms,Mm,Ma,Po	Se	Dr	
13	カントンの思い出 029店	Setback	1.7	4.7 (20)	RC			Aw,Ms, Mm,Ma	Se	Dr	
14	マニト	Setback	1.7	3.8 (20)	RC		Rs	Aw,Ms,Ma,Po	Se,As,Be,Sg	Dr	
15	ドヤジ屋	Setback	1.7	3.8 (20)	RC			Aw,Ms,Ma,Po	Se,As,Sg	Dr	
16	Chuo Sigean	Setback	1.7	5.1 (20)	RC	Ev		Ms,Ma,Po,Bn	Se,Sg, Um	Dr	
24	ヨブの王豚塩焼	Setback	2	7	RC	x		Ms,Ma,Po,Bn,Tv	Se,Be,Dw	Dr	
25	Kanton JMT	Setback	2	11.1 (14)	RC	Pr		Ms,Mm,Ma,Po	Se,Df	Dr	
30	Dongnara	Setback	2	5 (38)	RC	x		Ma,Po	Se	Dr	
21	75chacha	Cul-de-sac	1	9.3	Wd	Ev		Ms	Tb,Se	Dr	
22	Seoul Tiramisu	Cul-de-sac	1	3.8	Wd	x		Po	Tkw	Dr	E1E2E3a
3	宋家カムジャタン 別館	Setback-gap	1.5	5.9	RC	Ev		Ms,Mf,Ma	Se,Tt	Dr	
27b	キムズコスメ	Setback	1.3	5 (14)	RC	Pr		Hf,	Du,Sh	Op	
41a	Plac Shoes	Setback	1.3	4 (28)	RC	Pr		Ma	Du	Dr	
41c	Popskin	Setback	1.3	3.8 (28)	RC	Pr		Ma	Tr,Du,Ds,Su	Dr	
47	Starbox	Setback	1	8	Wd		Co	Aw,Tr,Ma	Du,Ds,Sh	Op	
50	BNshiny	Setback	1.3	3.3 (9)	RC	x		Aw	Tb,Ct	Op	
51	美肌工房 自然の森	Setback	1.4	4	S			Aw,Tv	Tr,Du	Dr	
33a	Happy Days	Setback	2.2	3.3 (19)	Wd			Aw,Tr,Du,Ma	Ds,Su,Sh,Tkw	Dr	
46	Skinholic	Setback-side	1.8	14	S	Ev		Ma,Mf,Bl	Gm	Op	
41b	NailParty	Setback	1.3	4 (28)	RC	Pr		Ma	Cr,Su	Dr	
45	U&美	Setback	1.2	3.2 (10)	RC	x	Fs	Cr,Hf	Su	Op	
17c	Unique Sense	Setback	5.5	3.3 (12)	RC			Aw,Bn	Tr	Op	
44	LaBelle	Cul-de-sac	0.8	3	Wd			Aw	Cr,Su	Dr	
39	Korea shop	Setback	1.6	2.7 (7)	RC		Mr	Aw,Hf,Du	Ct,Su	Op	
42a	Tina	Setback	10	2(18)	RC	Pr		[Masters shop]	[ShopX,Ludia], Hf	Dr	E1E2E3b
42b	FashionCafe	Setback	1	2(18)	RC	Pr	Fs	[Magic shop]	Hf	Dr	

38	Masters	Setback	10	18	Tmp	Ev	Mr	Hf,Ct	Gm	Op
52	ShopX	Setback	10	18	Tmp	Ev	Fs	Hf		Op
37	Ludia	Setback	10	18	Tmp	Ev	Mr	Hf,Tr,Du,	Cu, Um	Op
43	Magic shop	Setback	10	18	Tmp		Mr	Aw,Po	Cu	Dr

4.3.2 Content Appropriation Elements in the Encounter Patterns

Pattern E1 (1 Mr)

Analysis Example Fig 16

The entire setback is claimed by the contents. Customers are either on the street or within the interior of the content space without any threshold.

Pattern E1E2 (3 Rs, 1 Fs)

The edge E1 is loaded with appropriation elements to cause customers to slow down and stop. However, there is no movement to the interior and the setback becomes the main habitable space.

Pattern E1E3 (7 Rs, 3 Co, 1Fs)

Analysis Example Fig 17

The edge E1 continues to be loaded with appropriation elements but there is no opportunity to stay in the setback and customers are encouraged to move directly into the interior through E3.

Pattern E2E3 (1 Mr, 1 Co)

The edge condition is empty and customers are directly pulled into the encounter zone as the appropriation begins at E2. This provides opportunity for the customers to look and handle the products comfortably without causing a block on the street.

Pattern E1E2E3 (17Rs, 8Co, 6 Fs, 1 Mr)

Analysis Example Fig 16 and 17

All opportunities of encounter are maximized. The edge of the setback is overloaded with elements. An elongated threshold is formed by turning E2 into a habitable space to stay for a relatively longer period of time, for example waiting for a table in a restaurant. The setback is also used for storage, such as fridges and beer canisters. The customers become literally and figuratively surrounded by contents.

No.	Name	Physical Setting					Contents	Appropriation Elements Encountered			Encounter Pattern
		Setback			Const	Over head		E1	E2	E3	
		Shape	Depth	Width (Bldg)							
33b	Noraneke	Setback	2.2	3.5 (19)	Wd	x	Mr	Dr			E1

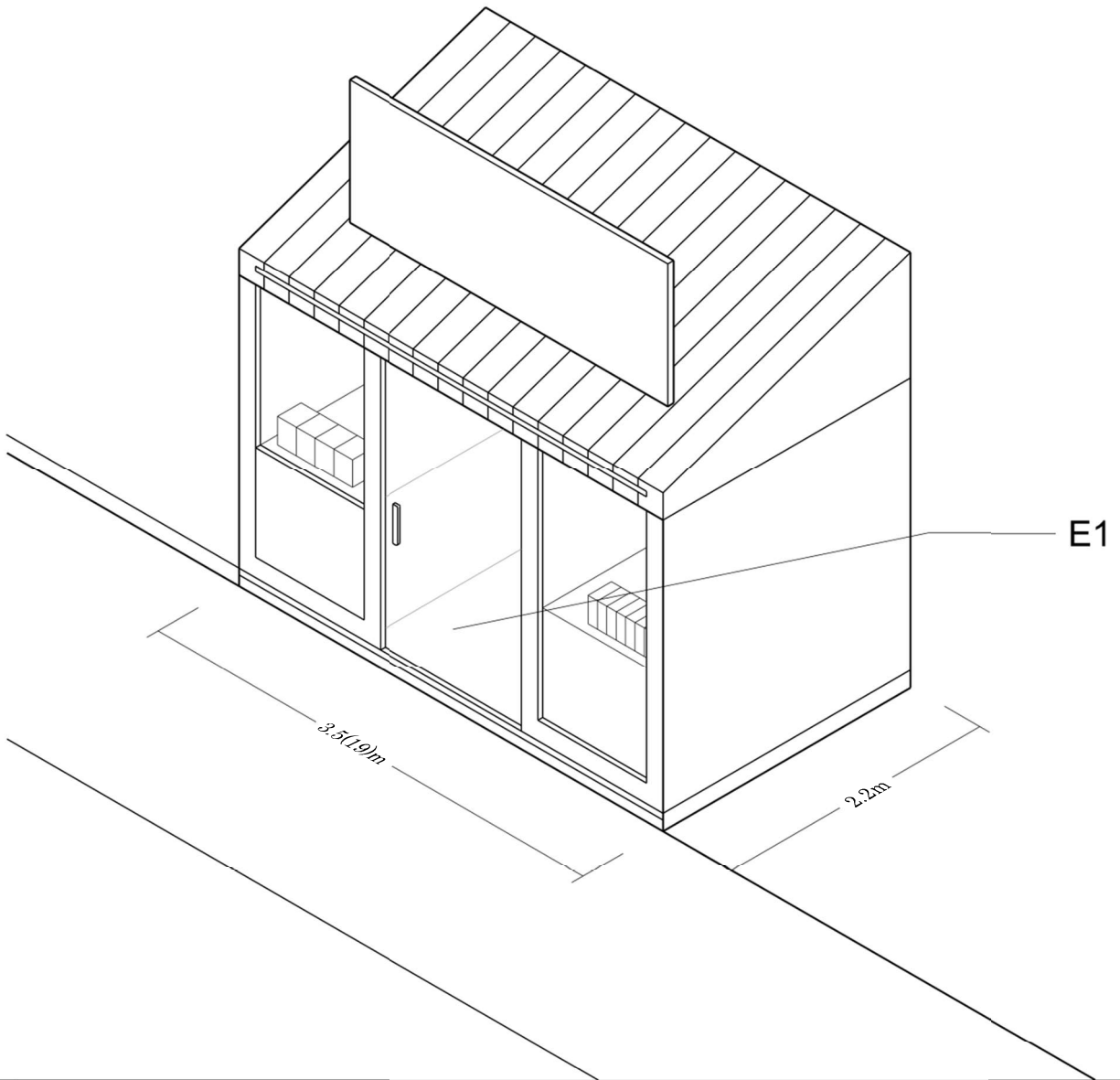



	Door (Dr)	
E1		
E2		
E3		

Fig 4.15 Analysis Example - 33b Mr E1

No.	Name	Physical Setting					Contents	Appropriation Elements Encountered			Encounter Pattern
		Setback			Const	Over head		E1	E2	E3	
		Shape	Depth	Width (Bldg)							
7b	美&知	Setback	1.2	2.3 (9)	RC		Co	Aw, Du, Ma	Op	E1E3	

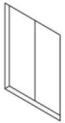

	Awning (Aw)	Mat (Ma)	Display (Du)	
E1				
E2				
E3	Opening (Op)			

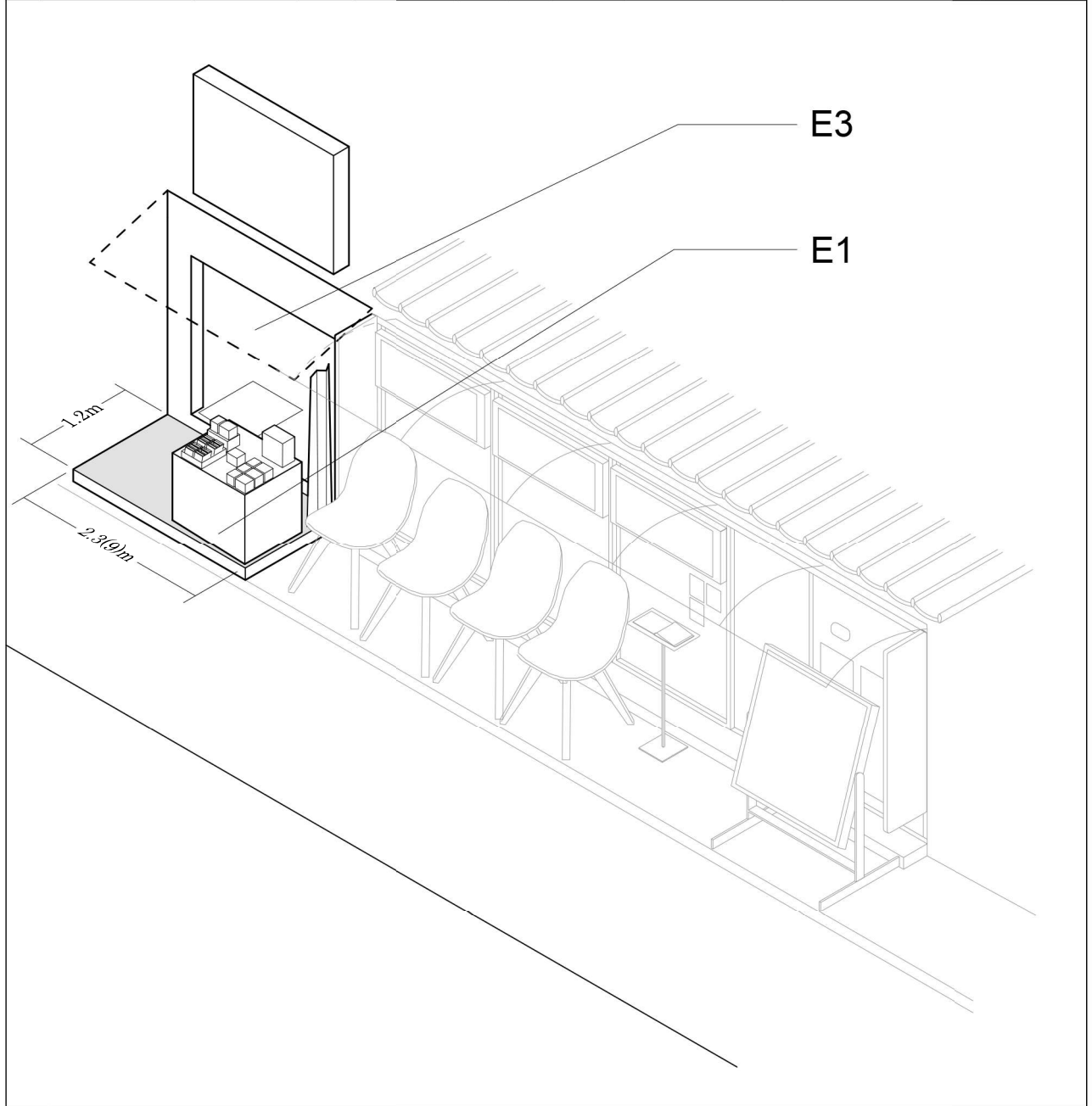
Fig 4.16 Analysis Example - 7b Co E1E3

No.	Name	Physical Setting					Contents	Appropriation Elements Encountered			Encounter Pattern
		Setback			Const	Over head		E1	E2	E3	
		Shape	Depth	Width (Bldg)							
7a	Soju Hanzan	Setback	1.2	5.4 (9)	RC	x	Rs	Ms, Mm, Po, Tv	Se	Dr	E1E2E3a

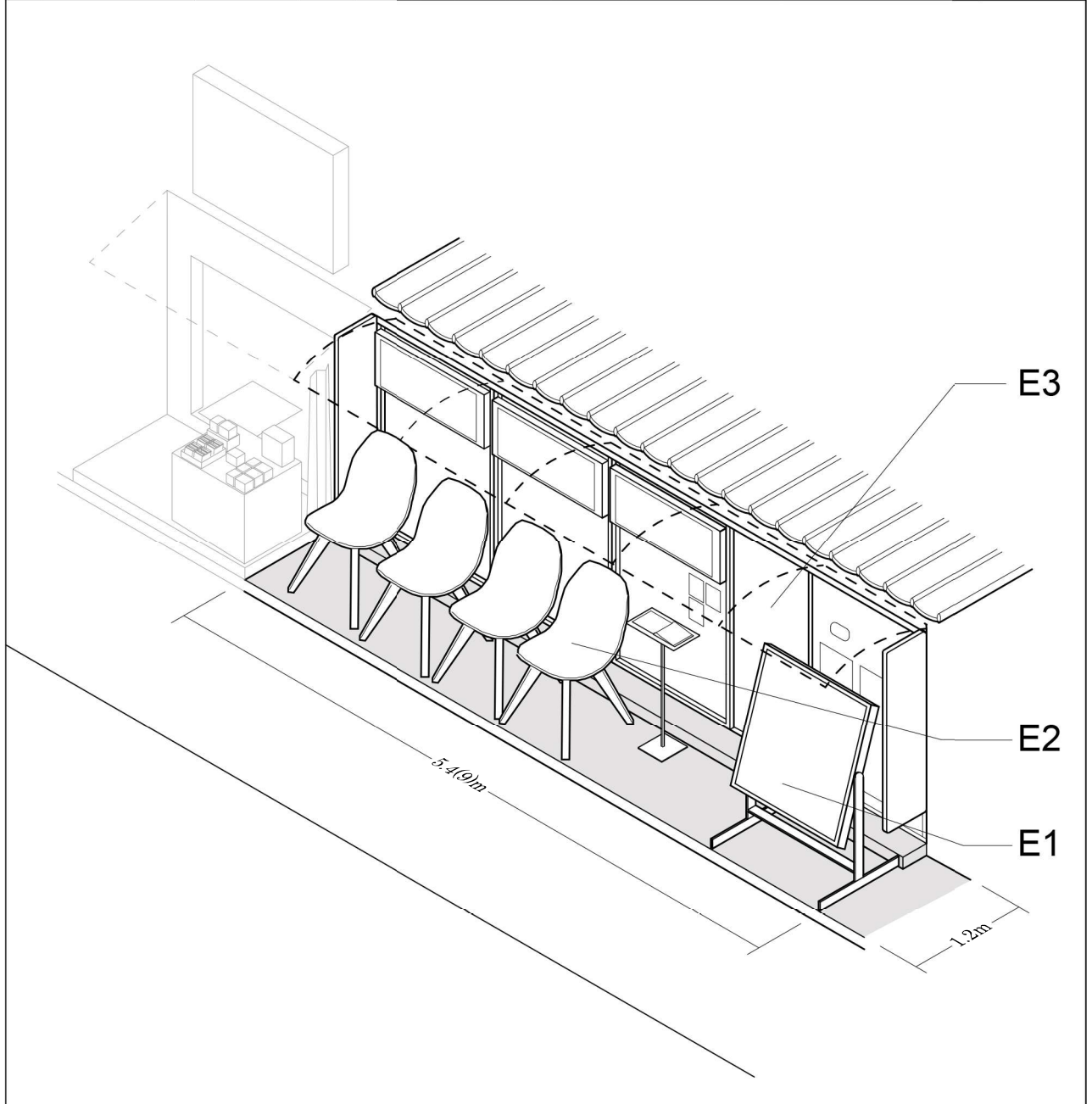





	Menu stand-large (Ms)	Menu stand-small (Mm)	Posters (Po)	Tv Monitor (Tv)
E1				
E2	Seating (Se) 			
E3	Door (Dr) 			

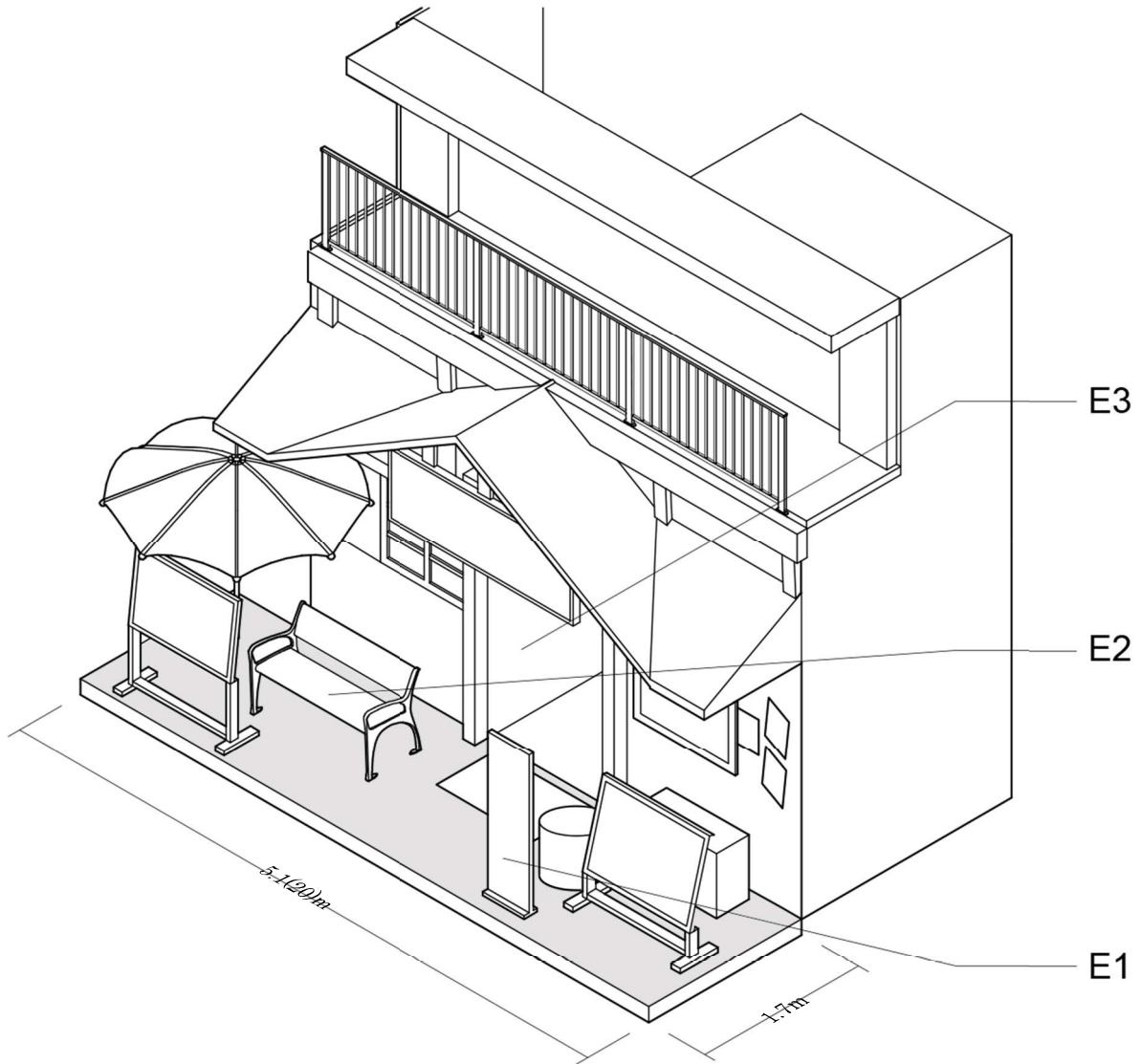

Fig 4.17 Analysis Example - 7a Rs E1E2E3

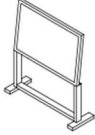
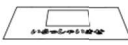
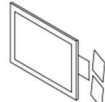
No.	Name	Physical Setting					Contents	Appropriation Elements Encountered			Encounter Pattern
		Setback			Const	Over head		E1	E2	E3	
		Shape	Depth	Width (Bldg)							
16	Chuo Sigean	Setback	1.7	5.1 (20)	RC	Ev	Rs	Ms, Ma, Po, Bn	Se, Sg, Um	Dr	E1E2E3a

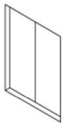

	Menu stand-large (Ms)	Mat (Ma)	Posters (Po)	Banner ad (Bn)	Umbrella (Um)
E1					
E2	Seating (Se)	Storage boxes (Sg)			
					
E3	Door (Dr)				
					



The photograph shows the actual building facade with various elements labeled E1, E2, and E3. The building has a balcony and a large umbrella. A bench is placed in front of the building. A menu stand is visible near the entrance. A storage box is located near the base of the building. A door is shown on the ground floor. The photograph is annotated with labels E1, E2, and E3 pointing to different parts of the building and its surroundings.

Fig 4.18 Analysis Example - 16 Rs E1E2E3

4. CONTENT SPATIAL PRACTICES REINTERPRETING A STREET INTO A HANRYU SHOTENGAI

4.3.2 Characteristics of Content Space- Ikemen dori

By analyzing Ikemen dori from the perspective of content space, we can extract the following characteristics:

a) Overloaded Edge

Along Ikemen dori, the edge, E1, is overloaded with appropriative elements. Visual images are the dominant element in regards to restaurants and it is not enough to use two dimensional posters and menus. The 2D visual element comes into the third dimension with the use of menu stands (Ms) and banner stands (Bn), thus occupying habitable space along with the person. Even if the finished product cannot be seen, visuals of it are arranged along the edge to deliver a sense of abundance. Similarly, as shops already have a finished product, clothing or skincare, they are also arranged with display units (Du) or hanging frames (Hf) to maximize contact with the customer. In addition to these factors, sounds from TV and music systems playing K-pop music blend with welcoming calls in Japanese (いらしゃいませ!) and move beyond the boundary of the edge.

The narrowness of Ikemen dori comes into play as the person, walking alongside with other people as well in the street, is then engulfed on both sides by the appropriating elements. The architectural setting is truly suppressed and is simplified to the container.



Fig 4.19 The Encounter zone completely hidden by elements of posters (Po), menu stands (Ms) and banners (Bn)

4. CONTENT SPATIAL PRACTICES REINTERPRETING A STREET INTO A HANRYU SHOTENGAI

b) Thickened threshold

By the appropriation of E1 to E3, the threshold does not remain a thin liminal space between inside and outside. Instead it gains body from the elements and becomes a thickened appropriated habitable space, where actions like waiting, eating, buying, perusing can be performed. In the case of restaurants, a person is either waiting to buy food or is receiving it from a takeaway window (TkW), or is sitting on chairs or benches (Se) on the setback. The setback also contains display fridges or storage boxes, conveniently hidden behind seating or menu stands.

In the case of shops, the scale of the setback comes into play. A shallow setback pushes the customer into the street and the contents are completely appropriating the setback (Analysis example 7b-Co). However, as the setback deepens / widens, it provides the customer with a comfortable place to peruse their products at leisure without creating trouble for other people in the crowd. The increasing scale of the physical setting allows for more and more appropriating elements. The physical setting of the setback becomes so large that the appropriating elements turn from 3D objects to habitable spaces.



Fig 4.20 Contents replacing the facade of the shop and spilling into the street

4. CONTENT SPATIAL PRACTICES REINTERPRETING A STREET INTO A HANRYU SHOTENGAI

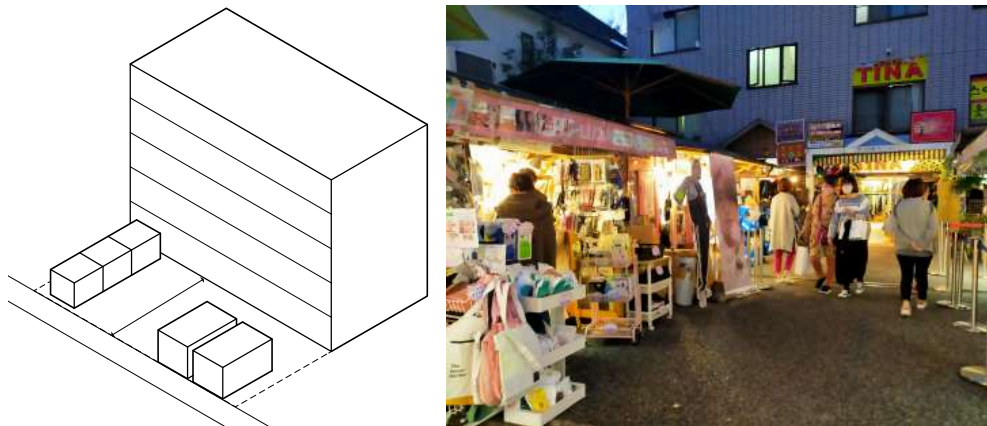

Fig 4.21 No 42a and 42b - The setback is wide and deep enough to have smaller shops as appropriation elements

c) Horizontal Economy of Agglomeration

In the study of zakkyo buildings as content space, it was concluded that though there was a successful vertical economy of agglomeration, it would not be as successful if the ground floor alone were to be used. However, in Ikemen dori, the majority of the shops and restaurants are on the ground floor, benefitting from the same friendly competition as seen in zakkyo building content space, but in the horizontal format. This expands the parameters with which content space can be seen in the urban realm.

4.3.4 Expanded lexicon to discuss Content Space

In previous discussions on content space, it was concluded that content space had the following qualities:

- (i) Immersion
- (ii) Convenience
- (iii) Diversity in choice

While these terms are precise in describing the content-space found in introverted individual places within the city, they lose their precision when analyzing content found in other systems in the urban context. This study suggests the following terminology be added to the lexicon to clarify urban content space.

- (a) Participation
- (b) Amenity
- (c) Curation

The following sections will discuss the logic of the terminology.

4. CONTENT SPATIAL PRACTICES REINTERPRETING A STREET INTO A HANRYU SHOTENGAI

a) Participation

Within dividual, interior-scale content space, the person is immediately surrounded by and has access to the desired product. The activity is solitary or within a small group already on friendly terms. There is no concept of *milieu*.

However, in analyzing the content space of Ikemen dori, a quality of participation can be detected. The narrow physical setting and the overloaded edge provides constant encounters with the appropriation elements to absorb the behaviour of people as part of the content space, whether it browsing products, or waiting on the set-back, or eating on the street. The encounter zone buffers people from entering directly into the interior causing the behaviour of seeing and being seen.



Fig 4.22a People eating in the street



Fig 4.22b Browsing while still outside

In the following pictures, there is a behaviour that happens frequently in Ikemendori. The crowd has gathered to purchase merchandise related to a particular K-pop idol on his birthday. The contents of Ikemen dori facilitate this immersion through participation.

4. CONTENT SPATIAL PRACTICES REINTERPRETING A STREET INTO A HANRYU SHOTENGAI



Fig 4.23 People gathering in Ikemen dori

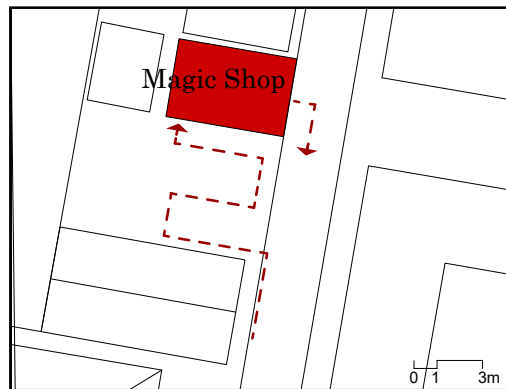

Fig 4.24 Magic shop, Ikemen dori - a catalyst for gathering

4. CONTENT SPATIAL PRACTICES REINTERPRETING A STREET INTO A HANRYU SHOTENGAI

b) Amenity

Content space found in zakkyo buildings has an element of hyper-convenience due to the centrality of their location and immediacy of access to the product. Comparitively, Ikemen-dori is inconvenient. It is a kilometer walk from the nearest train station. There is an abundance of product but the factor of the thickened threshold delays to access the desired content. Instead, Ikemen dori offers amenities. For example, The person in the photo is using the street as a third place, that is a place beyond work and home, for entertainment. After purchasing food at Jongno Hottok, she watches pay-per-view content about Korean idol shows using the services provided by Uncle Joe.

These behaviours can be performed indoors. But it is the nature of the content of Ikemen dori with its appropriating elements which allow such behaviours and amenities to exist and be accepted.



Fig 4.25 Woman watching Kpop videos while eating a cheesedog from Jongno Hottok

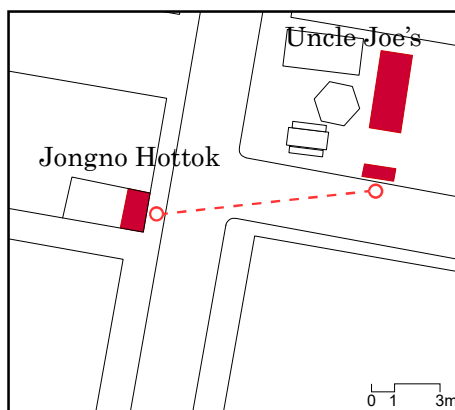

4. CONTENT SPATIAL PRACTICES REINTERPRETING A STREET INTO A HANRYU SHOTENGAI

c) Curation

Within content space, there is a diversity of choice for the user to choose. Yet in Ikemen dori, people gather here to specifically choose Korean products. This curation of Korean products of entertainment produces behaviours that are acceptable in Ikemen street but would be considered unusual or inconvenient in others.

For example, on weekends in Ikemen dori, it is common to see small, relatively unknown K-pop and J-pop groups to promote themselves by walking up and down the narrow street and hand out flyers to passerbys. It does not matter whether they are fans or not. The content space of Ikemen dori makes it an expected and acceptable behaviour. In the pictures below, we see a Kpop group promoting themselves by walking up and down Ikemen street. First come the band photographers, followed by the manager. In the middle are the band members who hand out flyers and information to the passer bys. Standing along the street are fans of the band who take pictures, and then ultimately join the train following the band to show their support.



a)



b)



c)

Fig 26

- a) Band photographers taking pictures of the group
- b) Band members handing out flyers
- c) Supporters forming a train behind the group

4.4 Conclusion

The global phenomenon of Hanryu, which is the enjoyment of Korean pop culture, has a hold in Tokyo. The consumption of Hanryu has not stayed in the virtual world of social media but is making itself tangible in the urban material world. This study analyzes this process from the perspective of commonalities. Korean Hanryu becomes an open commonality anyone can partake in freely regardless of difference in ethnic, social or religious background.

The flooding of urban space of Ikemen dori with Hanryu media gives formation to content space. The architectural setting is reduced to being a neutral container for the desired products of the content. The content utilize appropriation elements to create encounters with the public realm. The physical setting of Ikemen dori and the appropriation elements of the contents together form the encounter zone. The encounter zone was analyzed to clarify the spatial practices of the content to reinterpret a generic street in ShinOkubo into a Hanryu shotengai.

4. CONTENT SPATIAL PRACTICES REINTERPRETING A STREET INTO A HANRYU SHOTENGAI

References

1. Inaba, Y.: “The Power of Ethnic Town Okubo”
2. Kuwahara, Y: “Hanryu: Korean Popular Culture in Japan” Palgrave Macmillan US 2014
3. Kim, J: “Why Does Hallyu Matter? The Significance of the Korean Wave in South Korea” , *Critical Studies in Television: The International Journal of Television Studies*, vol 2, Issue 1. 2007
4. Mainichi Shinbun - “What’s behind the mix of K-pop culture boom and anti-Korean sentiment in Japan?” Oct 2021 (<https://mainichi.jp/english/articles/20211028/p2a/00m/0na/021000c>)
5. Flowers, Petrice R. “From Kokusaika To Tabunka Kyōsei: Global Norms, Discourses of Difference, and Multiculturalism in Japan.” *Critical Asian Studies*, vol. 44, no. 4, 2012, pp. 515–42
6. Almazan-Cabellero, J. Tsukamoto Y: “Tokyo Public Space Networks at the Intersection of the Commercial and the Domestic Realms. *JAABE* vol.6 no.1 May 2007 pp 143 - 150

5. HYBRIDIZED SPATIALITIES IN TOKYO

東京のハイブリッド・スペイタリティ

Abstract

This chapter explains the gradient of commonalities of closed, semi-open and open to extract the Principles of Appropriation of “Architectural and Behavioural Norms”, “Prohibitions and Preferences”, and “Expectation and Participation” in relation with the case studies. The introduction of migrant commonalities to a new location illustrates how the “commons” exist in contrast to the conventional norms of Tokyo. The migrant commonalities reveal the commonalities found in Tokyo’s granular setting, and the processes of appropriation in the urban environment by the three phenomena (a) Diversification and Identity, (b) Adaptation and Hybridization, (c) Conflict and Reconciliation were argued.

This thesis introduces a practical and theoretical framework to discuss the embedded spatialities of migrant commonalities within the nexus of the urban sphere. Cities are not just composed of their physical aspects but also contain social, cultural and ideological values. The introduction of a new set of socio-cultural values and practices from another geographical location creates tension but also opportunities. In this way, as people sharing values, ideas and practices that may not be identical to the local majority practical life, gather in the city, it is reflected in the use of material space and resources found in their new location. Shared ideas and behaviours constitute commonalities and their spatial practices makes their presence tangible in the urban space.

Spatial practices are directly concerned with the reproduction of migrant commonalities in their new locational setting. This thesis clarifies the methods in which the spatial practices of migrant commonalities appropriate the city of Tokyo by adapting the physical setting according to the behaviours brought from the origin countries. The commonalities investigated are not homogenous, nor are the people who are participating in them. Through this research, it is established that there exists a gradient within the commonal-

ities, depending on their source. This gradient ranges from closed, semi-open, to completely open.

5.1 The Gradient of the Migrant commonalities

In the following section, the main notions related to this gradient will be discussed. The chapters are arranged beginning from the closed commonality of religion. In terms of reachability by “non-members”, there exists a gradient. In the example of religion, it is easiest to differentiate between members and non-members, enabling a clear conceptualization of what is meant by “closed”. In this way, moving from closed to semi-open and then finally open, we see an increase in the members who are able to share the commonality.

a) Closed commonalities

The first are closed commonalities are those that are not easily permeated without changes in a person’s own ideological values and codes, represented in this thesis by the commonality of religion. Though religion is shareable, it cannot be entered without deep consideration. Religion is integral to many migrant people and is a factor that makes living in another country difficult, as food, drink and behaviour must be in accordance with the person’s religious code. In order to perform religious practices in the city, migrants must find and/or initiate spaces that allow the associated rituals to be performed optimally. Thus prayer venues become essential spaces of migrant commonalities in a new geographical location.

b) Semi-open commonalities

Semi-open commonalities are often the primary vehicle through which people are introduced to new cultures. Semi-open commonalities are those which are rooted in traditional culture but are easily shareable, for example food. Food is a factor easily accessible by the people of migrant minority culture and also the majority local population. It is perhaps the first level of introduction to a new culture and an appreciation for diverse food reflects positively as cultivation of cosmopolitan tastes for the local majority population. Yet, food is deeply personal for the migrant minority as for them it encompasses the taste but also memories, skills and religious values. In arriving in a new geographical location, many migrants are torn between the requirements of the body (food) and the requirements of the spirit (religion). By establishing semi-open commonalities in

the city, migrants reconcile such conundrums.

c) Open commonalities

On one end there are the open commonalities, those which can be entered by people of all backgrounds without any renunciation of religious values or conflicts with traditional culture. Open commonalities, represented by the pop-cultural phenomenon of Hanryu in this thesis, shows a new form of gathering spaces that are part of our urban realm. As global society has faced a worldwide pandemic together, entertainment provided by TV dramas and movies is a sorely needed source of escape from reality. Such escapism does not remain within the confines of the virtual but also takes its place in the urban reality. The area of ShinOkubo with its history of Korean residency and entrepreneurship became a strategic location in the introduction of the Hanryu pop-cultural contents to the real world. To come to the area is to have specialized knowledge and an appreciation for a foreign produced cultural contents, i.e, Hanryu.

5.2 The Principles of Appropriation

In the above section, the gradient of commonalities is established. This gradient gives us the principles of appropriation according to which the urban setting can be analyzed. The closed migrant commonality of religion has canons that dictate the behaviours performed by its members. These behaviours require prayer venues where they can be performed in an optimal fashion. The behavioural norms have corresponding architectural norms that must be addressed within the prayer venues. When the prayer venues are established in the new urban setting, the architectural norms must facilitate the behavioural norms while responding to the unique circumstances of the local context, which may not be compatible at certain points. Thus, the behavioural norms and the responding architectural norms become the principles through which the closed migrant commonality of religion can be analyzed in a city.

Within semi-open commonality of food, religion influencing traditional culture is most apparent. Food is a meeting point of many complex interrelations for migrant people living in their host country. First, food responds to their religious requirements, if any exist. Second, the food is prepared according to traditional culture methods, which may be shared between migrants of different religious backgrounds but who have a similarity in regional locations. Third,

5. HYBRIDIZED SPATIALITIES IN TOKYO

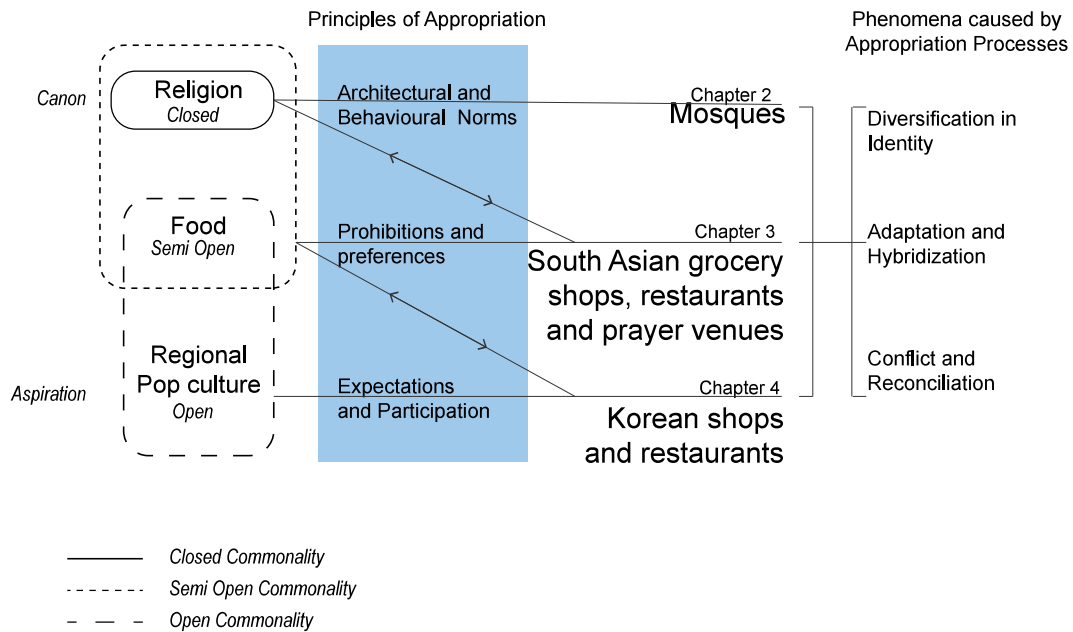

Fig 5.1 Principles of Appropriation

food is one of the most accessible means of sharing between people of different cultures. These points of contact for these complex dynamics take place in a city in spaces through ethnic grocery stores and restaurants. It is the principles of “prohibitions and preferences” that make such complex dynamics physically tangible within the urban realm.

Open commonalities overlap with semi-open commonalities on the point of food. Open migrant commonalities, such as regionally specific pop culture, manifest in the urban realm through shops that sell finished products representative of a certain region, such as clothing, merchandise, beauty items, as well as ethnic restaurants, where the cuisine is presented as a finished product. These representative shops directly address the desires and aspirations of a segment of society who want to experience a fantasy realm produced by regionally specific pop culture, exemplified by Hanryu in this thesis, in the actual physical reality. This principle of “collective consumption” becomes apparent as the region-specific pop cultural products are consumed by the enthusiasts in the urban sphere.

5.3 An Expression of the “Commons” by the introduction of “Migrant Commonalities”

In the present-day globalized society, there is a hard delineation between what is considered the “public” sector, “private” sector and the “commons”. The term “commons” here refers to a resource or situation that is formed by a group of people with similar values coming together. In attempt to offset the overuse of space, i.e., the tragedy of the commons, there is an implementation of privatization, which leads to urban spaces to become highly commercialized to extract profit. Such phenomena make it difficult to see how, if any, commons that are organically formed by people still exist within our cities.

Through the case studies explored in this thesis, the framework of migrant commonalities suggests a new appearance of the “commons”. For example, in chapter two, mosques were studied. These prayer venues are initiated, cultivated and in two cases physically renovated by Muslim community members. The mosques are not limited to just to prayer, but are a method for new migrants to Tokyo to gain a foothold in their surroundings. Questions about employment, preferable areas to reside, business opportunities, dealing with the bureaucracy, and a host of other factors related to living in Tokyo can be resolved by tapping into the network of people also using the mosque. Thus, people are coming together due to their commonality of religion and forming commons.

This thesis has discussed how the agglomeration of migrant commonalities affects the urban character. For example, in chapter three, the clusters serve as attractors to migrants, both long term residents and new ones. The South Asian ethnic restaurants and grocery shops are places of employment, as they primarily engage people sharing their regional background, but also sustain the traditional habits and preferences of their fellow South Asians living in Tokyo in accordance with any religious requirements. The relatively high concentration of relevant facilities provide scope to live according to South Asian customs within the Japanese socio-spatial context, thus forming commons on an urban scale.

Similarly, the Korean content spaces discussed in chapter four offer similar resource networks and employment opportunities as the

5. HYBRIDIZED SPATIALITIES IN TOKYO



Fig 5.2 Assalam Mosque



Fig 5.3 ISKON Hindu Temple

South Asian facilities, but there is an added dimension of Hanryu, which is propelled into the urban reality through media. New types of behaviour, such as watching K-pop videos on the setback while eating street food, are introduced which are specific to that area only. A form of commons is created by both the providers and consumers of Hanryu in ShinOkubo. The appropriation practices performed by the providers is affirmed by the consumers. This reciprocal relationship is continuously repeated along the street. Thus, people start collecting to appropriate the threshold between public and private to form their commons.

Thus, as migrant commonalities are coming from the “outside” the country and are practiced in an organic unstructured way, depending more on the migrant people’s initiation and effort, without “public” or “private” interests applied to their operations, it is easier to see how commons are still alive within the city.

5.4 Migrant Commonalities meeting Tokyo Commonalities

This study illustrates the heterogeneity and complexity found in the migrant commonalities. Such commonalities are to be found in any city or locality where people from different regions live together and perform the practices to execute their own ideas on the usage of their physical space. As this thesis has shown, the appropriation methods are replicable but not uniformly so, depending on the historical context, political and economic climate, availability of usable space, etc.

The unique urban structure of Tokyo has developed in response to a multitude of factors, some natural, such geographical topography or earthquakes, and some human-made, like war, urban policies, or the mass transit system. Yet, as migrant offer their commonalities, Tokyo in response offers its own. The small-scale grain of built structures readily available is extremely friendly to the flexible appropriation, and their presence in central locations such as Shinjuku and Taito facilitate the migrant commonalities to proliferate rapidly and gain a foothold in their new surroundings, discussed in chapters three and four. Similarly, the distinct morphology of the tall and narrow “pencil” buildings is a common feature of Tokyo streets. Their hybridization with the closed migrant commonality of religion can be used to develop a distinct notion of a Tokyo prayer venues, as shown in chapters two and three. The tendency of Tokyo

commercial spaces to be distributed vertically as well as horizontally provides migrant commonalities with usable space that they may not have found in their home countries.

Thus, there is a mutual exchange of commonalities, creating new types of behaviour in the urban spaces within Tokyo.

5.5 The Encounter of the City and the Commonalities

The gradient of the migrant commonalities exists in the socio-spatial reality of the urban sphere, appropriating the physical setting according to the requirements of the spatial practices. For the spatial practices to be performed, different actions are taken to reconcile the migrant commonality with the existing setting.

a) Diversification in Identity

Throughout this thesis, there has been a concentration on the granular level of the city, as it is at where people have the agency to adapt their surroundings with their own power. A diversification of identities is tangible at this level. The facilities of ethnic shops, restaurants and prayer venues can be considered as small interventions in the urban setting. By selling commodities or cuisine tied to a distinct region outside of Japan, the identity of the facility stands apart from the local majority. The agglomeration of such small interventions at variance from the cultural norms of the host society within a local area proceeds to compound this difference in identity of the urban character. In chapter 3, exploring South Asian food and prayer commonalities, and in chapter 4, exploring Korean pop cultural commonality, the a change in the identity of a locality in Tokyo due to the relatively high representation of ethnic facilities within small area in the urban physical setting is evident. Over time, this change in identity becomes deeply rooted in how the city developed.

b) Adaptation and Hybridization

The presence of a new set of religio-cultural behaviours in a geographical location which previously did not have much tangible representation in terms of built structure and physical location means that the existing physical setting will have to be suitably adapted. As there is no previous example to follow, the knowledge and experience from different geographical locations is then applied to the new setting to create hybridized versions. This is most evident in the chapter 2 of “Spatial Practices of Mosques in Tokyo”,

5. HYBRIDIZED SPATIALITIES IN TOKYO



Fig 5.4 Hindu Priest in front of Sacred Objects



Fig 5.5 Person watching K-pop Idols on the street

5. HYBRIDIZED SPATIALITIES IN TOKYO



Fig 5.6 Chuo Sigean in Ikemen dori

where the prayer venue of mosques has strict behavioural norms that had to be reconciled with the urban material reality of Tokyo by the adaptation of the architectural norms of the mosque itself. This form of negotiation done by the adapted architectural norms create a hybridized version of the mosque, where the vectors of unchangeable ritual behaviour and fixed physical setting collide. Yet, this hybridization does not remain on the architectural level only. Discussed in the chapter 4, ShinOkubo is a location which is well known for the diversity of people residing there and has a long history of Korean residents in the area. This relation between ShinOkubo and Koreans is firmly rooted in the collective consciousness of people residing in Tokyo, a change identity as previously discussed, which made it the ideal location for Hanryu-related activities to be produced. The street colloquially referred to as “Ikemen-dori” becomes the prime example of a fixed architectural and material terms of an urban location being flooded by collective ephemeral imageries of entertainment and social media activities. The hybridization happens on a metropolitan level between the Japanese city and Korean entrepreneurs, then between urban physical setting and the fantasy setting provided by social media. The contents do not remain in the interior space but creep out into the public domain by appropriative action. The contents create a

many layered encounter zone that engages interest in the knowledge but also visual and aural sensations of the commonality.

c) Conflict and Reconciliation

There is a distinct imbalance of power between the migrant arriving in the host city and the established hierarchies of power that dictate behaviour in the public domain. Migrant spaces can only go so far in appropriating the city. This is most clearly described in Chapter 2 in the Spatial Practices of Mosques, when traditional architectural norms have to be reduced or deleted when the mosque typology is replicated in Tokyo. The prime example being that of the behavioural norm of Adhan. As it is an auditory announcement and cannot be replicated in Tokyo, it leads to the architectural norm of the minaret of mosques in Tokyo to lose their function.

And yet, the presence of migrant commonalities explored in each chapter indicates how the practice of migrants in making spaces for themselves in the city moves against the assumption that long-term residents would be absorbed by the cultural norms of their host society. Instead the spaces containing migrant practices reverse the expected position by turning the city into a resource to be adapted to specifically articulate their difference. Explored in Chapter 3, migrant places operate in a gray zone. The expectation of standardization is not heavy on the places of migrant commonalities, allowing them to claim surprising places and operate according to niche movements of their community members. This results in a form of freedom to act in marginal spaces. Opening a grocery shop above a kebab stand (Chapter 3 - Sunshine Halal, Ikebukuro) involves a sense of humour in addition to entrepreneurial spirit. Such forms of surprising encounter are abundant in multiethnic Tokyo.

5. HYBRIDIZED SPATIALITIES IN TOKYO



Fig 5.7 Sunshine Halal in Ikebukuro

6. CONCLUSIONS

結論

In the following chapter, the relevant conclusions gleaned from each chapter will be compiled to give an overall understanding of the thesis.

6.1 Introduction

In this chapter, the concepts of commonalities were explained in how they interrelate with theories of spatial practices. The movement of people is not just of bodies through physical space, but also of ideas and practices. Using the resources of the new settings and the knowledge learned from previous places, commonalities are formed. Commonalities are defined as transcending borders, communicating between human beings but defies ownership by one particular group of people.

The city becomes a grand metacollector, which not only collects but also acts as a commonality that is then shared by people migrating from different regions. This chapter covers the historical background of migrants that have been entering Japan. The introduction also covers the aim of the thesis, which is to clarify the changes in identities, conflicts and adaptations that take place when spatial practices of migrant commonalities negotiate with the existing socio-spatial setting of the city. The methodology was also explained,

which includes the selection of the case studies within Tokyo and how the theoretical framework was applied in the analysis. The objects of study were discussed and the thesis organization was summarized.

6.2 The Spatial Practices of Mosques in Tokyo

As explained in the second chapter, prayer venues have a strong identity. The mosques in Tokyo were chosen as the example to illustrate how behavior may change the physical setting on the interior and exterior levels.

As Japan is a non-muslim majority country, Islamic architecture is not vernacular.. Yet Islamic architectural elements are associated with certain behaviours of the religion. That is why they are utilized when a mosque is built in Japan. This chapter examines how the architectural elements, termed as “architectural norms”, are modified when encountering the building and social conditions in Tokyo to ensure the behavioural norms of the religion can be optimally performed.

It was determined that conflicts arise when replicating a mosque between the architectural norms and the urban condition and varying degrees of adaptations must be taken. Mosques were both purpose built and renovated buildings. Behavioral norms, such as the Adzan, were completely removed, reducing the associated architectural norm of the Minaret to a visual symbol. Behavioral norms such as the Wudhu and Salat, which could not be removed, had to have their associated architectural norms be suitably adapted for their practices to be appropriately performed. The Wudhu area could only have the most basic configuration fulfilled. The Salat area had the architectural requirement of having one wall perpendicular to the direction of Makkah, along the Qibla axis, which affected the orientation of the people using the building during prayer. Also, the separation by gender was prioritized, which led to mosques to rely on devices like TV monitor systems to connect the women’s Salat area to the Imam in the Men’s area.. Only the three mosques that had Mezzanine levels could provide a direct visual connection between both.

The analysis clarifies that it was the architectural norms that had to negotiate between the optimal performance of the behavioral norms and the urban condition of the city, whether the building is purpose-built or renovated an existing building into one.

The mosques were categorized into seven patterns from A - G

according to the non-removable factors of Wudhu and Salat. The variety of patterns displays the heterogeneous manner and different combinations the architectural adaptations can be executed to respond to Tokyo's conditions. Even though the mosques share a similar goal, i.e., to provide a space for the practice of Salat in a communal way, yet they are not hegemonic in their adaptations or identities. Some prioritize a nationality in addition to the religion while others focus solely on their Islamic religious identity.

The mosques in Tokyo give us the unique opportunity to understand how commonalities can be transferred from one location to another, and the methods in which the associated architectural norms must negotiate with the original behaviour and material form of the city.

6.3 The Spatial Practices of South Asian Commonalities of Food and Prayer within Tokyo

The investigation spanned across Tokyo to illustrate how the commonalities formed by migrant spatial practices are embedded in the nexus of the city. The two commonalities of food and religion were explored. The commonality of food was represented by the facilities of grocery shops and restaurants, while the commonality of religion by the facility of prayer venues. Six locations were identified where the facilities were creating a relationship with the local train station and were termed as "clusters".

The clusters were divided into three categories: (1) Home-Train Station, where South Asian residents made their homes, (2) Market, where the presence of existing markets encouraged the South Asian shops to start their businesses in the area, (3) Religion, where the establishment of a prayer venue led to many shops opening nearby. The spatial practices of these facilities, in tandem, affect the urban character of the cluster. The framework of Space, Practice and Identity was used to clarify the spatial practices of the facilities. The grocery shops formed a gradient of identity, from highly specific to more inclusive of people of different religioethnic backgrounds, depending on the customers to whom they adapted their practices. The identities were performed by selling consumable items that were both culturally and religiously relevant to their customers.

The restaurants represented their identity by the cuisine that they served, which could be representative of a single country or a fusion of some. While most restaurants attempted to attract the most customers, some accommodated the religious dietary restrictions, depending on the communities present in the cluster.

The identity of the prayer venues were formed by religion. Each prayer venue had a degree of exterior and interior adaptations to accommodate the ritual behaviour of the religion. However, three of the mosques participated in affecting the urban surroundings by using elements associated with Islamic architecture on their exterior facade. On the other hand, the three temples of the Hindu, Sikh and Jain religions were more introverted and used Sacred Objects within their building in performing their religion.

The different urban character formed by the varying spatial practices highlights the heterogeneous ways commonalities are used in the city. Comparisons were able to be drawn between the clusters: ShinOkubo with Kamata; Jujo with NishiKasai; and Ikebukuro with Okachimachi.

ShinOkubo and Kamata highlighted how the commonalities of food and religion are not used in a monolithic manner. Different communities, based on ethnicity, religious and cultural practices etc., have their own methods of using and producing commonalities in the city. Ikebukuro and Okachimachi show how a prayer venue attracts other facilities of similar background around it and is a catalyst for a cluster to be initiated. Jujo and NishiKasai demonstrate how a cluster can develop a very strong identity by the spatial practices of the facilities. Jujo having a strong religious Muslim character whereas NishiKasai has a strong national Indian character. Thus, it is clarified that the heterogeneous spatial practices of commonalities are manifested through facilities of grocery shops, restaurants, and prayer venues, making evident the diverse populations inhabiting Tokyo.

6.4 Content Spatial Practices Reimagining a Street into a Hanryu Shotengai

This study looks at the global phenomenon of Hanryu and its effect on the urban content space of Tokyo through the framework of migrant commonalities. Hanryu, which originates in Korea, has firmly taken hold in the cultural space of Japan. Korea and Japan have a difficult past, yet Hanryu provides a fantasy setting where international strained relations can be sidestepped. The global pandemic was another factor that drove people to seek new forms of entertainment besides the mainstream. These factors are reflected in our urban setting.

ShinOkubo has always been known as a place of Korean entrepreneurship and residency. This made it the ideal place for urban

Hanryu content space to take root. Unlike individual content space, which is introverted and separated, Hanryu content space is collective and overt. In order to discuss this duality, the appropriation behaviour of the content on the physical setting of the setback. The content of Korean restaurants, skincare, fashion and merchandise were examined to see the appropriation behaviour and clarify the elements used.

It was found that the appropriation elements of the content created a multilayered encounter zone on the setback. This zone was divided into three part from E1 to E3. The elements responded to the behaviour of the people in the physical setting. The edge condition of the setback was overloaded with information and the threshold space of the setback was thickened to create a habitual zone where people could wait, shop, eat etc. The encounter zone was analyzed to clarify the spatial practices of the content to reinterpret a generic street in ShinOkubo into a Hanryu shotengai.

6.5 Future Considerations

This thesis has propelled the discussion on commonalities by introducing the concept of “migrant” commonalities and analyzing them through the framework of a gradient. It is a necessary step to further discussions involving the complex relations that take place when new forms of behaviour are introduced to a different context. The investigations into the new forms of behaviour start in the second chapter, by analyzing the introduction of a non-local religion, Islam, and its space of practice, the mosque, into the Japanese urban context of Tokyo. The architectural norms of the mosque are the point of mediation between the fixed socio-physical setting and the performance of the unchangeable ritual practices of the religion. Similarly, such mediations take place in other non-Muslim majority countries according to their local contexts. This chapter provides an opportunity to compare the strategies of appropriations that take place in other contexts, and opens the door to examine how appropriations take place outside the built structure, using the city at large, as well as the response to a post-COVID world. In the third chapter, the investigations focus on the South Asian populations that reside in Tokyo. A holistic view of the response in the city to the relationship between the commonality of religion and that of food is provided by this study. Furthermore, the understanding of clusters being formed by the activities establishes a temporal relationship between the city and the commonalities according to the principles of appropriation. Yet there remain

6. CONCLUSIONS

other methods of appropriating the city practiced by other minority populations in Tokyo. This thesis provides a critical methodology with which to clarify the actions taking place when understanding commonalities in the city. There is more to understand on how other minorities may use each other's spaces as well as producing their own. The fourth chapter develops on this position a bit further by analyzing the area of ShinOkubo, which contains both "Islam-yokocho" and "Ikemen dori". ShinOkubo is related with Japan's colonial past, the Bubble Period of the economy, and is now colonized by the action of the Hanryu commonality. This chapter starts the discussion on how the fantasies produced by pop culture has a real and tangible affect on the urban reality by creates spaces of consumerism and also new behaviours. Further elaboration can be made on how people belonging to previously colonized regions appropriate space as their own culture starts to occupy cultural space in the consciousness of their ex-colonizers. Such complex dynamics emerge as social media takes greater hold of our daily life and areas such as ShinOkubo become points of contention and mediation..

Appendix

a. Spatial Practices of Mosques in Tokyo

[Part 2]

Notes and Appendix:

- A. References
- B. Records of interviews of Study Case
- C. Sketches of Study Case
- D. Analysis of Study Case

A. References

Note 1: Stewart, 'Bodies, Visions and Spatial Politics', p.610. quoted by Kim knott . 'The location of Religion', 2005, p.39

Note 2: Lefebvre, The Production of Space, p.33. quoted by Kim knott. 'The location of Religion', 2005.p.39

Note 3: Kim knott, The location of religion, 2005.p.40 chap. religion and lefebvre's spatial triad

Note 4: Kim knott, The location of religion, 2005.p.40 chap. religion and lefebvre's spatial triad

Note 5: Eposito, John.L.Oxford dictionary of Islam.2003

Note 6: Leacrof, Helen&Richard. The Buildings of early Islam, p.2, 1976

Fig F1: Leacroft, Helen&Richard .The Buildings of early Islam, p.2, 1976

Fig. F2: Frishman & Kahn, The Mosque

Note F6,F8,F9,F10: Frishman & Kahn. The Mosque: History, Architectural Development & Refional Deiversity.2002, Thames & Hudson

Note 7: 店田廣文、日本のモスク：滞日ムスリムの社会的活動、2017、日本

B. Records of interviews of Study Case

Questionare

BUILDING

1. When the building was built, and who initiate?
2. Was it renovated or new building?
3. Who designed?
4. What kind of facility does it have?
5. How and who built it? Contractor or self-build?
6. Why choose this site?
7. How much is the capacity of the mosque? (Jumaah and eid)

ACTIVITY

1. What kind of program do you have?
2. What do you do in Eid day?
3. Which part of the room is it use for those program or activity?
4. How is it when its Ramadhan?
5. If there is feast, where is the food come from?

PEOPLE

1. Who manages the mosque?
2. Who is the Imam?
3. Who is mostly came here? Student?

Al Ikhlas Mosque Interview

Wawancara dengan Pak Anwar (Direktur SBI Remittance, Akihabara, Tokyo)

A: Yang saya cari pertama saya datang, kelompok dzikir. Pengajian. Terus dikasih tahu sama temen. Disitu kana da masjid. Wah Lebih asik lagi nih saya pikir. Uda deh saya kesitu. Cuman masjid itu jelek dulu, parah. Sampe orang Malaysia suka disitu, bilang 'ini gap antes dibilang mesjid', tapi kagak action kagak ngasih duit. Benerin apa gimana. Saya bilang, ini saya renovasi ya? Gitu saat itu. Nah ini lanjutan kenapa saya bilang tadi semua berawal dari ngomong doang. (0059) wah ikhlas bgt saya kalua direnovasi. Saya ngomong doang ternyata, ga punya apa-apa saya, nganggur. Terus temen belum punya. Itu 2009, setelah itu berjalannya waktu saya kerja di.... Tadinya saya kerja di nyapu jalan. Nyapu jalan di Tokyo.

Abi situ saya dapat kerjaan, memotong pohon. Mereka motong pohon, rantingnya dan dahan kan jatuh, nah saya dibagian bawahnya itu. Bagian nyapu2 bagian jaga2in kalua ada orang yang lewat. Jadi kata2 bahasa jepang yang saya kenal awal2 tu itu. Hokosha toorimasu. Itu doang. Sama jiten-sha toorimasu. Sepeda. Orang lewat, mereka berenti motong.

Saya menikmati pekerjaan itu tapi lama2 jengkel juga karena kerja fisik kan, fisik capek, memori turun. Baru 3 bulan kerja masuk bulan romadhan. Agustus itu ga puasa, berat. 1 tahun saya kerja itu. Akhirnya saya putuskan untuk berhenti. Udah saya di kabukicho aja setiap pagi, kams sore. Tapi sambil kegiatan dzikir ikut. Nah temen selama bulan itu.

Sama2 temen2 yang dzikir, bantuin, bantuin ngecor, saya ngangkatin semen pasir apa segala macam. Ada yang bantuin kerjaan saya kerjanya bogkar2 rumah. Bantuin, ada lagi nurunin daging di shinagawa, konteiner itu. Yang 40 feet yang panjang dagin beku tuh. 20 kg 30 kg penuh itu kita yang turunin, pake conveyer. Pekerjaan itu segala macam dah. Background saya pramugara yang notabenenya agak2 bersih dikit laa. Setree, saya selalu menikmati pekerjaan itu tapi saya jadi jauh dari bacaan. Wah bahaya ni. Berenti, dzikir, minta kerjaan.

Sampailah tahun 2011. Ada perusahaan jasa kirim uang yang masih baru. Perusahaan jepang. Saya lagi jumaatan, ada yang nawarin kirim duit. Liat brosurenya masih sederhana sekali.

Nah saya liat itu saya bilang, ini kenalin aja sama bos nya ini kalo saya yang pegang dijamin maju tu perusahaannya. Saya saat itu main jeplak gitu aja. Sukses besar jadinya sekarang, orang tahu perusahaan itu. 2014, saya pikir saya mendingan buka perusahaan sendiri. Dengan punya usaha sendiri saya bisa punya masjid. Nah itu emang udah cita2 gitu. Jadi cenderungnya cita2 geser2 ngomong doang. Taunya bener. Ada jalan aja yang ngasih tau cara bikin perusahaan gini2. 2015 saya keluar dari perusahaan yang itu (remittance jepang) cari partner, dapet partner yaitu SBI remit. SBI remit itu perusahaan orang jepang yang lebih gede lagi. Lebih gila lagi konglomerat itu. Kawin sama perusahaan saya, karena ga mungkin orang asing punya usaha sendiri. Gandeng dong. Dia yang lebih gede, dia yang urusan duit. Gitu. Bagi hasil deh kita.

Begitu 2017 ditunjuk sama anak2 disini, saya ditunjukan buat jadi ketua Lazis NU, jadi saya tahu NU itu di jepang. Lembaga Amil zakat infaq sodaqah. Saya bignung. Ngerti juga ngga.

Saya mau bayar zakat di SRIT, pas saya masuk pintu kaca tuh yang didalam, Nah ini dia ni orgnya nih. Ini bu ketua Lazis NU. Ada ibu2 mo bayar zakat, maen nunjuk2 aja becanda tapi pasang muka

serius, jadi si ibu itu juga jadi muka serius. Saya juga ga mungkin kek anak kecil dong. Kasian ibunya. Jadilah ketua Lazis NU jepang. Karena saya ilmunya ngga ada. Dan gara2 3 org itu. Ya udah saya ke PBNU untuk belajar jadi Lazis NU. PBNU di Jakarta. Jadilah saya presiden Lazis NU Jepang. Saya luncurkanlah program pengadaan renovasi masjid sejepang. Sekali lagi tui ngomong doang.

Tau2 anak2 di tochigi ken (0949) pada beli masjid ngehubungin saya. Beli bangunan bekas pabrik. Murah dapet gede banget. Kiainya ngontak saya. Ayo pak kita bikin pesantren pak. Sekali lagi ngga ada yang punya kurikulum. (intermezzo) (1040) Nah pengimamannya dimana? Karena 2 lantai. Itu jatah saya yang lantai 2 yang laen ga boleh ikut campur. Saya kan ada yasinan, tahlilan, malam jumat di Nishi Tokyo itu ada anak2 yang kerjanya emang dibangun, kerja kayu. Daiku. Tukang kayu di jepang. Saya ajaklah mereka. Itu betul2 kerja ikhlas ongkos juga ongkos sendiri. Lazis NU itu ga da untuk ngasih itu ga ada. Cuman untuk makan mereka Sano ada yang ngasih anak2 santri sana lah. Jamaah sana. Itu lantai 2 kita garap, semuanya. Pasang peredam. Itu Lazis NU cuman punya duit 200.000 yen. Disana anak2 beli tok, bangunan tapi buat renovasi ga punya duit. Nah sehingga main pasang sedapet2nya. Saya bilang loh itu kenapa dipasang? Pake peredam. Duitnya ga ada. Itu pertama kali. Coba itung berapa, ya 150.000 sih kang. Ya udah saya Tanya Lazis NU ada duit berapa? 200.000 yaudah transfer duit ke Sano 150ribu buat bikin peredam. Transfer lgsg jess, belanja mereka. Mulai anak2 itu garap, pengimamannya, mihrabnya buat imam, mimbarinya. Itu tim kita semua. Ya memang anak2 tahlilan yasinan itu yang garap. Selesai, gimana nih oke ngga kalo ada masjid lain? Siap seneng ya ibadah. Padahal besoknya kerja lagi mereka. Jadi mereka sabtu pulang kerja, berangkat malem. Minggu. Bangun jam 4 pagi karena sholat subuh dan segala macem. Terus dikasih makan mereka langsung kerja lagi sampe malem. (1250) malem pulang paginya mereka kerja lagi. Tui luar biasa sekali anak2 itu. Saya bilang saya dulu ada ucapan masjid kabukicho. Sekian tahun lalu. Dateng lagi mereka. Tadikan duit kita 200.000 dipake 150.000 tinggal 50000 kan? Karena nyari duit itu ga gampang, nyari duit sumbangan itu susah. Kalo untuk organisasi, karena bawa nama organisasi. Lazis NU. Kan ada NU nya. Karena tidak semua orang suka NU. Atau dia berpikir disalah gunakan atau segala macem, padahal lazis NU jepang duitnya emang digunakan untuk di jepang. Program saya ya itu tadi. (renovasi masjid sejepang) (1338) Duit cuman 50000 saya itung2 ah paling habis 750.000 yen. Karena semua. Akhirnya kita copot semua lantai kita copot, tangga kita copot bikin baru semua. (renov masjid kabukicho) sementara samapahnya aja 7 truk. Ada meja bar yang begitu2 dibongkar. Satu kali angkut 60000. Kita punya duit cuman 50000. Itungan saya 750.000(total). Dari sampah aja 6x7 aja udah 3.5. gimana mo beli prabotan ama material?. Penggalangan dana kita. Itu memeang urusan masjid itu susah dengan nalar itu susah. (1435) setiap yang kita butuhkan itu dapet. Makanan yang kita bawa pasti pas. Saya masak atau saya pesen. Ada yang sadaqah bento. Berapa orang kang? 12 saya jemput 12. Eh emang bener 12 ternyata. Padahal tadi kita ga tau berapa org. mikir saya yang bakal dating cuman 4. Pikir ya udahah buat makan sore ntar malem. Eh taunya emang dateng lagi 5, 9, trus pas abis. Ntar malem dateng lagi juga. Ketika kita butuh duit. 150 untuk belanja makan total, cuman kan ga mungkin, usaha saya belum jalan. Baru ngerintis jadi belum ada duit. Udah ini

aja diprint aja buku bank coba deh. Eh tauya ada. Ada duitnya ambil 150rb belanja lagi. Beli lagi. Sampai 2.200.000 abis. Karena 3 lantai kan. Semua itu baru, papan, baru, tangga baru, carpet baru. Semua. Itu 2.2 juta. Udah peresmian kita. Tahun 2016. Itu Idul adha 2016. Jadi. (1630)

Anak2 kenshusei nishi Tokyo yang renovasi semuanya. Kerjain sendiri termasuk listrik2. Karena kontraktor ga ada yang mau. Saya ga tau kenapa. Karena mungkin ada yang 'jagonya' ada kali ya. Mungkin ya. Tapi kontraktor ngga mau. Jadi kita garap sendiri. Selain itu kontraktor mahal. Ya kita ga tau apa kita diboongin karena orang asing. Tapi disini jarang sih ya ada gitu2. Disini bisnis biasanya kan fair ya. Ya jadi udah tuh. Muali dipake. (1750) rebana lah segala macemlah, gombrang gambreng2, udah rame deh. Kemudian usaha saya berjalan. Berkantorlah diruangan kecil ini. Ini sendiri berdiri tahun 2017. Saya sendirian disini. Lalu nambah karyawan ada total jadi 6. Kan susahkan sholatnya. Saya masih pingin ada musholla. Karena di akihabara. Kalo sebelumnya saya masih mikirin diri sendiri aja tinggal sholat disini gampang. Ini ruangan yang tadi kita meeting, itu pemilik gedung ini di disitu. Ini kan jadi ada 2 pintu kan. Saya (dulu) cuman ini doang. Seuprit gini doang. (sebelah) kantor dia (pemilik bangunan) disitu. Tempat dia bercengkramalah, orang udah tua sih, orang cuman ngelukis doang. Terus karena rame. Saya bilang kita harus cari kantor lagi ni. Yang agak gede. (1928) kalo dapetnya diluar kan kantor ini ga mungkin pindah ni. Karena akte perusahaan alamatnya ini. Ruangan ini kita jadiin tempat makan dan gudang. Sementara disini (satu bangunan) penuh saya udah Tanya.kalo emang kita dapet(kantor)nya digedung ini, maka ruang ini jadi mushollah. Gitu. (1953) akhirnya gedung itu udah oke. Tau2 dibatalin ama dia. Terus yang didepan situ udah oke juga, tau2 dibatalin. Karena katanya mau...? Sebulan itu nyari2. Akhirnya yang punya gedung ini kontak saya, katanya lagi nyari? Anaknya yang punya gedung ini. Bilanglah yang disini ama orang tuanya. Dirayu2 lah entah gimana. Dan orang tuanya juga mungkin suka ya, ama kita. Akhirnya dikasih kita nyewa itu. Nah ucapan saya kan kalau dapet ruangan ini jadi mushollah. Maka ini jadi mushollah. Diresmikanlah waktu itu. Oleh pas lagi ada disini Kiai Abdul ghani (Ketua MUI DKI Jakarta) ada 5 orang itu. Mushollah aja diresmiin ya gaya bgt. Cuman seumprit ini doang. Seperti itu jadi formal, pake doa dan yasinan disini. Formal. Udah kantor disitu, mushollah disini. Disini jadi mushollah kita promosikan di google. Rame bgt. SBI Mushollah. Rame bgt, turis lah belum lagi yang dzikiran disini. Trus dipikir2 harus sewa lagi ini yang lebih besar. Yang kepikiran udah masjid dong. Bukan kantor lagi, kantor cukuplah segitu. (2151) Nah Bulan 3 2019 sebulan sebelum Ramadhan yang diatas ini (5F) habis kontrakannya. Ini kontraktor nih, yang ngontrak. Yang ngebangun hotel2 didepan ini. (depan gedung kantor SBI). Tapi mereka mau perpanjang, nah yang punya gedung bilang ke saya. Ini yang atas abis kontrakannya, mau ngga? Ya saya mau klo satu lantai karena untuk masjid. Mushollah penuh. Ya dia setuju. Ya sudah saya sewa. 260.000/bulan. Toh saya ngga khawatir, perusahaan kan dah jalan. Dia bilang oke ya udah. Jadilah sama anak2 itu juga yang renov. Cuman belum sempet sempurna mereka udah harus pulang ke Indonesia karena habis kontraknya. Nah disitu saya kehilangan tim. Nah itu jadi seperti itu. Dan saya untuk yang atas saya ngga promosi kemana2, karena udah ada duit. Udahlah dari perusahaan juga cukup. Tadinya saya pingin pake Jadi masjid spirit baru. (2351) tapi istri saya usulnya jangan. Kalo nama kantor nanti kalo kantor tutup, atau saya meniggal

dunia, kan mesjidnya tutup juga. Iya dong. Jadi pake apa ya. Pake nama organisasi aja, pake nama NU. Gitu. Masjid Nusantara. Nama nusantara sendiri sih sebenarnya yang usul professor Azis. Azis Muhammad sekarang ketus KMII. Pake nama masjid Nusantara aja. Ya udah, tapi ngga usah pake NU nya. Istrinya pake NU nya justru, supaya nanti anak2 NU kalo kita meniggal anak2 NU yg lain yang nerusin. Sama aja klo cuman masjid nusantara ntar imejnya saya lagi. Meniggal, seolah2 itu masjid milik saya kan. Kalo pake ada NU nya ya udah milik NU. Bukan milik Anwar gitu. Untuk bikin masjid itu NU didaftarkan disini sebgaia ormas. Jadi NU itu resmi berbadan hukum. Baruah kita bikin masjid dengan nama NU itu. Tapi kategorinya kita tetep yang bayar pajak.

Itu aktenya, Ke notaris bikin yang resmi (dalam Bahasa jepang). Untuk lantai 5 itu NU. Jadi bukan SBI. Nah itulah langkah2nya. Karena denganberdiri mejid NU ini kan tinggal buka masjid nusantara dimana lagi, tapi kontrak. Kenapa kontrak sih? Kenapa ngga beli? Untuk di Tokyo, selain ngga punya duit, beli. (Intermezzo, Pak Roji, Ketua Pencak Silat NU **di** Jepang) Sebenarnya yang NU itu istri saya, saya brut ahu NU pas disini. Istri saya dari dulu NU santri, cuman S3 nya disini. S1 dan S2 di UI.

Itu kontrak 260.000. yang di kabukicho 88.000.(per bulan) sewanya. Tapi ama yang laen2 taroklah 150.000. yang disana mahal sampahnya. Ya 2 mesjid itu kita kelola, hamper 500.000 lah sebulan. Nah itu dibawah Lazis NU. Gitu. Dari mana duitnya? Selain dari infaq. Saya diakte NU Jepang kan Nama saya. Itu perusahaan spirit baru kan nama saya juga. Saya bikin kontrak kerja sama antara SBI dengan NU. Jadi zakatnya masuk ke NU. Infaqnya juga masuk ke NU. Itu untuk ngebackup bayar kepentingan masjid-mesjid. Ini gambling saya cerita karena isunya rame bgt. Waktu baru bikin ada yang bilang bantuan dari jokowi. Saya bisa kenal dari mana jokowi, klo kenal mah gw kagak ngontrak, beli. Belum lama ini ada beirta lagi tribun news tuh rame. Tentang masjid radikal, judulnya sih kursus jurnalisme, tapi beritanya tentang mesjid2 radikal di jepang. Kecuali masjid nusantara. Akhirnya kan dianggapnya orang berpikiran itu kita. Yang bikin berita itu, atau mesen. Apa kepentingannya. Nah kayak begitu. (3017) Isu terbaru dapet bantuan dari Ahok. Makanya saya juga kaget berarti gaungnya boleh juga masjid ini. Sampe ada yang fitnah gitu kan berarti, say amah ngga persoalan bgt karena saya tahu. Gw harus bikin perusahaan dulu baru bisa bikin masjid. Kantornya kecil seumpriit tapi punya masjid. Kayak BUMN kan. Makin banyak fitnah makin banyak duitnya.

Nah disini ada apa saja programnya. Itu (Pesantren) pun impian saya. Karena saya bukan anak santri tapi, bikin masjid NU. NU identic dengan pesantren. Kalo muhamaddiyah kan identiknya dengan sekolah dan rumah sakit kan gitu kan? NU kan 'sarungan'. Nah anak2 yang S2, S3 disini ternyata banyak sekali backgroundnya itu pesantren. Itu bikin saya kagum. Gila, ini pesantren. Kalo saya lahir besar di Jakarta. Pesantren itu identic dengan kampungan. Atau anak yang terkena narkoba jaman dulu tu. Anaknya bandel terus narkoba tu pasti dibuangnya ke pesantren. Ketika disini berubah semua pola pikir saya. Makin seneng saya ama NU. Masuk ke kalangan agamis dia ngga gagap karena dia ngerti, bahkan hamper rata-rata bisa Bahasa Arab. Masuk di dunia akademisi pun dia bisa ngimbangin, bahkan banyak yang berprestas juga kan. Sabtu jam 13.30 siang ada TPA (Taman pelajaran Alquran), nah itu anak2 kecil. Saya bikini bubur kacang ijo. Methode

Tillawatih. Pencetusnya temen-temen yang ngurusin Kabukicho. Mba sintia, lagi S2. Mas Arif (suami mba sintia) sendiri muhamadiyah. Terus Salahudding lagi S3 di Waseda. Dan ustad Nasril Alba kemarin. Nah ustad-ustad, kita panggil dari Indonesia, kita kontrak per tiga bulan. Setiap Ramadhan kita panggil 2 Ustad, karena kan. Taraweh di Kabukicho dan Taraweh disini (Nusantara). 3 bulan, 3 bulan tuh kita kontrak. (3443) Nah kemarin pas Angkatan Ustad Nasril ini ustad muda. Ini dari Al Hikam depok. Pesantrennya almarhum Kiai Haji Muzadi. Mantan ketua PBNU. Nah itu dia yang programin atau yang melaunching, udah pake method tillawatuh aja. Kayak disana (Di Indonesia) Tanggal 28 kemarin (Oktober 2019) baru abis selesai 3 bulan pulang. Nah tanggal 7 besok datang penggantinya ustad Idris, masih muda. Umur 22. Tapi rata2 semua hafal Quran, bisa baca kitab. Itu syaratnya itu. Hapal Quran. Mereka bisa baca kitab kuning karena memang pesantren. Nah mulai tanggal 7, tanggal 8 Ustad Idris udah ada. Kita setiap jam 10 pagi itu pelajaran kitab kuning. Kitab kuning itu, kitab yang warnanya kuning. Ngga ada Harokatnya. Arab gundul. Nah belajar. Setiap hari senin-jumat jam 10. Nah ini yang saya harap bisa jadi cikal-bakalnya pesantren. Kenapa harus jam 10. Ya saya harus strict dulu dengan waktu. Karena kalo saya Tanya gimana jam 10, nanti yang kerja pada bilang susah. Pokonya satuin aja dulu bret kalo mau silahkan datang setelah datang ikut baru usul. Mau kapan. Berapa org jemaahnya atau santrinya? Nah setiap hari jumat disini jam sholat siang, mulai jam 12.30. tapi jam 12.00 siang itu baca surat Al-Kahfi. Selesai surat Al-Kahfi itu ngaji surat Ain. Itu dari awal Al Quran tuh, dari Al-Baqarah awal, sekarang sudah masuk Al-Imran. Semua, semua yang datang kita kasih Al Quran, buak sama2 baca. Itu selesai 12.20. Dah mulai tuh bilal. Terus pakai tongkat, persis seperti masjid-mesjid NU pada umumnya. 12.30 mulai khutbah, selesai jam 12.50 itu harus. Kenapa? Makan keluar, kita kasih makan, makanya didepan sini ada freezer kan? Freezer gede itu isinya daging-daging. Untuk umum. Daging-daging itu di beli oleh SBI. Ini saya omongin lagi, buat terserah ni. Kalau ditulis kan jadi pada ngerti yang tadinya ngomong. Dari ahok lah, dll.

(3828) Itu untuk umum. Tapi Alhamdulillah, mesti ada aja kek tahun lalu yang dari wilayah tohoku. Fukushima itu ada yang sodaqah, ada petani yang nyumbang beras. Perkebunan dia juga punya sawah. Dia nikah sama orang sini (Jepang). Tapi yang menarik itu yang Makoto Garden Berkarya. Itu orang Indonesia suami-istri. Itu lebih keren, sampe punya kebun gede. Padahal kesini itu sebagai perawat. Tadinya suaminya. Itu juga orang NU juga. Itu sampe punya kebun gede banget. Itu suka ngirim. Singkong, kang titip ni daun singkong juga. Nanem singkong di jepang. Gede2 dia bilangnya singkong samurai, panjang. Panjang bgt segini. Satunya aja gede bgt. Saying habis, kemarin ada kita sempet nge goreng singkong, di freezer sih ada tuh yang dingin. Tapi beku. Nah yang kek begitu2, yang nyumbang ikan, sayuran, segala macem. Nah itu kita harus segera salurkan kalo ada sumbangan-sumbangan itu kan, itu makanya jumat ngasih makan kita. Ya seneng jemaahnya. Karen apa dari pada makan diluar susah. Nayrnya juga butuh waktu, udah habis jumat duduk. Setidaknya 40 org tuh kita pake baki, bareng2 makannya. Ini kita alasin plastic udah lauk pauk gitu. Rata2 9 bakilah per hari jumat itu. Satu baki untuk berempat.

Pak Anwar yang masak. Itu saya mendengar salah satu, dulu mahasiswa today, dia ceramah harus punya ibadah unggulan. Kan kita sholat masih belang-belang sholat sunah boro-boro. Apa yang

bisa kita andalkan nanti? Tahu-tahu seperti ini. Saya ngga punya atau tidak mempersiapkan diri jadi pengusaha. Saya tidak bawa duit dari Jakarta, zero. Tahu-tahu saya bisa jadi begini. Ya tidak besar memang, buat orang lain ini kecil. Buat saya ini beasr sekali. Perusahaan ini ternyata ngurusin masjid. Setiap yang datang, ini bukan kamu aja lho yang saya tawarin makan. Setiap sholat kan makan bareng2. Dan ngga pernah kita dia harus NU, atau dia harus punya kartu SBI. Ternyata memang betil yang namanya sodaqah itu efeknya dahsyat banget. Ngga pernah saya promosi-promosi, marketing dan segala macem. Hampir ngga pernah, udah biarin ajalah rejeki udah ada yang ngartur. Sekarang kami cuman berempat sama saya. Satu mba Narti itu istrinya Mas Antos itu dia ngebantuin saya di Lazis NU, untuk admin di Lazis NU. Itu doang kita. Mana sempet kita keluar2 untuk marketing, orangnya aja dikit. Betul-betul rejeki diatur sendiri itu betil. Yang penting kita kelolanya ketika kita dapet kelolanya itu untuk apa. Ya disini freezer itu tarok disitu, ya udah buat siapa aja. Kamu juga kalo mau bawa aja. Pake kantong kresek, ga usah beli. Itu kan feedbacknya ada ke kita. Ketika kita memang, kenapa saya harus ngasih, kenapa orang itu ngambil, karena disini sulit nyari makanan halal. Atau kebetulan juga saat itu dia pengen tapi kebetulan lagi ngga punya duit. Itu kita ngalami, saya dan istri ngalamin. Dulu kan ngga ada medsos. Agak susah juga nyari2 makanan halal. Berdua kita ngga bisa Bahasa jepang lagi. Ya sudah waktu saya habis untuk (ini). Dulu weekend ketika kerja di perusahaan orang. Weekend itu adalah waktu yang tepat untuk marketing. Karena anak2 kenshuseinya kan libur, saya datang-datengin rumahnya bikin kartu (SBI rem.) Tapi weekend sekarang sudah sempit waktunya untuk ngurusin masjid. Kamis pagi saya udah harus ngeluarin, daging beku, untuk saya olah malem jumatnya. Pagine finishing. Kalo ikan ya malemnya sudah saya rendem pake asem garem, nah pagine gorang. Hari jumat pagi. Nah saya dari pagi itu tas kerja saya udah lauk pauk. Kalo malam jumat bulan pertama, kan setiap malam jumat di Kabukicho itu yasinan. Maka, makan2nya disana (kabukicho) itu setiap malem jumat. (4442) Kan kalo disana 13.30. Ya udah ngga pantes buat makan siang, jadi ga ada makan siang. Dulu ada tapi ngga cocok. Maka di malem jumat makan2 nya. Nah itu gentian siapa yang mau nyumbang siapa yang mau nyumbang. Disini juga kita ngumumin, yang mau nyumbang siapa, satu kali makan.

Tugas saya itu gitu, kamis udah bawa daging, kan jumat selesai jumatn bawa lagi, untuk yang hari sabtu. Anak2 madrasah, kan orang tua nya juga makan dong. Untuk makan lagi. Itu masak besar, masak banyak, kenapa? Karena malem minggu, pada yasisnan disini. Siangnya kelas malemnya yasinan. Terus makan malem lagi. Itu tiap minggu. Jadi pokoknya dari Kamis sampe minggu malem, udah deh saya ga bisa. Istri nitip kosmetik juga ga sempet saya beliin. Jadi udah full di dapur. Masak di rumah terus bawa kesini. Jadi sabtu jam 11an saya udah disini lagi. Tadi jam 11 saya udah disini karena baru mateng. Sabtu jam 11 saya kesini masak ya, kalo kacang ijo anak2. Minta tolong anak2 masakin. Atau saya. Kalo kacang ijo gampang lah. Tapi lauk pauk saya dirumah. Masak nasi disini anak2. Udah untuk anak2nya makan, orang tuanya makan. Kan ngga kena biaya. Udah yang penting belajar. Pas keluar dari sini, otaknya isi perutnya isi. Dah kenyang gitu. Nah malem minggu anak2 yang kenshisei itu kan pada baru pulang kerja tuh. Nah berkumpullah disini mereka. Jam 20:00 tet itu yasinan. Yasinan tahlilan baru kajian. Mo ngaji apa, selain itu masa

yasin doang. Malem jam sebelas mereka mulai rebana. Sampe pagi. Malem minggunya baru tuh anak2 baru anak2 itu masak, tapi dagingnya baru kita keluarin. Dari sore. Untuk sarapan minggu pagi. Minggu pagi mereka makan udah yang lanjut tidur lagi yang lanjut apa lagi. Kalo yang lanjut nginep disini ya tidur lagi disini ya masak lagi buat minggu siang. Jadi padet kali itu. Kalo masak kecil atau dikit disini. Tapi kalo udah besar saya dirumah. Dulu disini sempet mampet, pusing saya waktu lagi mudik. Mampet. Ya yang namanya umum kan banyak orang, kita cerewetin yang satu yang satu nga tahu. Ya jadi seperti itulah. Itu nikmatnya. Toilet ada jendelanya, buang tissue di jendela. Alhamdulillah pusing.

Ya kayak begitu, hiruk pikuk, nikmatnya ngurus masjid. Lebih sibuk dibanding ngurus perusahaan. Kita judes orang ga mau dateng lagi.

Nah Idul fitri kemarin. Mesjid ini selesai direnov 1 minggu setelah selesai Ramadhan. Sebelum Ramadhan diresmikan. Diresmikan oleh Pak Andri Ardiansyah mewakili KBRI, beliau kepala bagian politik, pokoknya petingginya politik di KBRI, dan kiai haji khairul annam, ketua NU Cianjur. Yang sekarang ketua PUSDAI Bandung. Beliau yang bawa figura ini, itu, jadi total 4. Saya kaget. Kiai yang bawain. Saya udah salah tingkah. Terus saya Tanya, kenapa kiai mau bawa2 begini. Kiai muda aja belum tentu mau kalo dibawa2in begini. Ini dia bawa sendiri. Nah dia bilang. Pak Anwar, tahu ga di NU itu Nadatul ulama itu kapan lahirnya. Tahun 1926 orang nya udah ga ada pendiri2nya tapi masih ada kan? Masih tetep didoain kan? Dia kenapa mau begini2 ini nanti sekian tahun lagi masjid nusantara ini kan akan mendatangkan ustad yang ceramah2 trus dipakai pengajian2. Tapi yang ngga bisa diganti, penceramah pertama itu saya. Yang meresmikan itu saya. Saya lagi matok sejarah. Beliau yang doain. Nah itu mulai tuh Ramadhan. Kalo tidak Ramadhan aja saya weekend sibuk. Ramadhan disitulah baru kalian, kita semua ini harus menghargai masakan. Seroang ibu. Pusing tau. Tadi kan flownya udah jelas saya pagi, daging beku sudah harus dikeluarkan dari freezer. Supaya sore cair, sore cair ini untuk dimasak untk kapan? Bukan untuk buka, kalo buka terlalu mepet. Untuk sahur, harus ngeluarin segera atau malem, ketika taraweh keluarin daging. Itu untuk buka puasa. Jadi ngeluarin daging ketika buka puasa buat puasa besok, ngeluarin daging ketika sahur buat sahur besok. Tiap hari, bukan jumlah kecil. Paling sedikit 50. Mesjid masih baru, penuh. Tiap hari. Pulang ke rumah bawa sampah, kan sampah banyak. Masa kita buang disini. Di apartemen saya lah. Jam 12 malem pulang buang sampah oleh2nya. Tiap malam 5 kantong gede. Pulang mandi, balik lagi kesini. Ngirim makanan yang untuk sahur kan. Untuk sahur sekalian saya subuhan disini. Selesai itu balik lagi ke rumah istirahat. Bangun jam 11. Harus masak lagi segera untuk buka puasa kan. Sampe sini jam 5 sore. Udah makanan udah matang. Untuk yang buka puasa, segala macem selesai buka puasa tarawih segala macem, mulai ngeracak lagi bumbu2 segala macem. Pulang bawa sampah lagi masak lagi cepet2 dirumah. Bawa lagi kesini gitu deh sirkulasi. Mandi malem terus. Tidrunya kacau, Alhamdulillah sampai lebaran yang dateng kesini 400 orang. Mesjid segede gitu kapasitas paling banyak 100. Yang dateng 400. 4 gelombang. (kapasitas normal) bisa 100 org. Seperti itu, idul fitri.

Selesai lebaran tumbang saya 8 hari. Kurus badan saya. Saya sampe panic sendiri. Ini kok kenapa ya. Jadi gampang capek. Ya udah minta mas zaki (org jepang). Cariin saya lab, saya mau cekup.

Cuman dokternya kaget. Kok badannya sekarang bagus. Turun 9kg. bagus pake program apaan? Mau ikut program saya? Masuk islam aja. Puasa sebulan. Kek gitu tumbang saya. Istri saya begitu, kaget dia. Suami sendirian udah begeng. Ini baru ni, baru naik lagi. Ya seperti itu. Ini ni seperti ini dapet setoran nasi kebuli dari KBRI. Ada juga orang mesir, macem2 ya karena masjid kan.

Bulan puasa sempet ngasih. Jadi yang pernah kesini2 itu. Professor nazarudin umar, Imam besar masjid Istiqlal. Habib jindan, dah kesini. Kalo masjid kabukicho kebih banyak lagi, karena lebih tua. Terus yang bersyahadat sudah 8 orang, melalui masjid ini. Udah orang-orang jepang 7, orang finlandia 1.

Saya aja ga bisa ngedampingin (Prof.Nazarudin Umar) karena saya aja sibuk. Kita mana punya duit (untuk ngundang beliau) tau2 pokonya dimana ada acara, kiai2 indonesia. (5827) mereka yang itu minta dateng kesini. (diliatin foto) Mesjid itu berat, capek. (ngurusinnya) tapi ya akhirnya jadi. Makannya pake baki (Arabic style?).

(yang meninggal) disini dimandikan di KBRI. Mungkin cuman dia (nunjuk foto) yang meniggal, yang dateng banyak sekali, terus ada tahlilan. Kan dia jamaah kita. Jamaah sini. Kalo disini malam minggu, dia malam minggu kerja, jumat tahlilannya disana di kabukicho. Yasinan. Meninggalnya pulang kerja merasa pusing. Anaknya masih kecil, istri dan anak baru dateng ke jepang 2 minggu. Iya dikbur disana (Indonesia).

Di Kabukicho ngga ada perayaan Idul fitri, supaya semuanya ngumpul disini. Jadi kayak di kampung di Indonesia kan gitu, masjid kan banyak, tapi ketika idul fitri atau jumat kan di masjid tua. Di masjid yang gede. Disini. Karena mo bilang gimana sini basecampnya NU. (010220) (010352) Ini kalau idul fitri jadi tempat cewek, yang ruang meeting juga jadi tempat cewek buat sholat. Makanya ada TV tuh di bawah papan tulis. Mesjid semua buat cowok. Cewek disini, makanya ada TV ada speaker, tuh buat itu. Jadi bisalah disini 10 disitu 10.

Jadi meja putih itu (yang ada di meeting room) dia akan keluar kedepan lift buat nyimpen tas. Kan yang ribet itu biasanya tas. Orang dari mana gitu kan bawa tas ransel. Udah kita harus ada yang jaga. Tas harus disini, ga boleh dibawa dalem. Yang lantai 4. Lantai 5 buat sepatu. Kan lantai 4 depan lift kosong kita tarok meja. Tas dituu. Ya udah cewek2 kesini. Makanya bisa dilihat disitu ada tempat wudhu, itu tempat wudhu cewek, makanya diatas ada pengumuman tempat wudhu cewek dibawah.

(010651) Intermezzo cerita tentang Pak Roji. Istri pak roji mewakili pencaksilat di jepang. Cerita tentang pencak silat di jepang.

(011218)

Kalau suara seperti apa? Bagaimana respon kantor lain terhadap masjid akihabara?

A; Mereka mengerti. Aku baru pasang peredam hari kamis kemarin. Abis pengimaman itu. Itu kana da whiteboard, itu kan sengaja ga pake peredam. Saya kirain ga da orang disitu, tahunya ada orang yang tidur disitu. Udah saya pasangin. Makanya rebana sepet libur seminggu. Malem minggu kemarin baru ada lagi.

Q: Disini kantor pada tutup jamberapa?

A; Jam 19. Mesjid tetep on sampe isya, musim panas atau musim dingin. Disini bulan puasa cewek

juga ada, buka bersama. Seneng deh pokoknya Ramadhan ini walopun capeknya. Cuman ya itu kalau ada tamu saya ga bisa nemuin, walaupun sekelas Prof Nazarudin Umar ya tetep aja. Para tokoh2 tua lah. Karena saya di urusan dapur sih.

Q: Pas nyiapin ada keulitan untuk nyiapin sejadah atau karpet, atau furniture2 yang dibutuhkan masjid, seperti mimbar itu gimana?

A and R; Itu bikin sendiri semua. Anak2 nishi Tokyo, kenshusei hajime. Tukang kayu, daiku. Disini pas lagi shok itu lebaran doang.

Q: Pada saat event seperti itu, orang2 ngumpul di luar masjid ngga? Seperti di Otsuka Mosque?

A: Kalo jualan makanan ngga ada. Soal ngumpul2, ngumpul. Ini sambil saya kirim foto2nya ya.

Q: Saat Idul Adha seperti apa pak?

A: Belajar dari idul fitri. (011715) Kita tuh kalo pengumuman pasti bilangnyanya khusus buat laki-laki karena, kalo untuk perempuan di iyain, perempuan itu bukan hanya tas yang dibawa tapi kereta dorong bayi juga. Nah itu kita kasina nantinya ke merekanya, naroknya dimana. Sebenarnya dulu disitu, ruang meeting itu ada sofa. Cuman begitu sofanya tiap malem jadi rebutan tempat tidur disitu. Jadi saya buang. Ganti aja sama kursi meja lipet. Dulu sofa, 2 empuk. Ketika sholat susah tuh, mau dipindahin kemana sofanya?

(011908) Intermezzo sambil nunjukin waktu tempat depan lift dijadiin tempat tas.

Idul Adha jumat jatuhnya.

(011954) Pak Anton datang dengan anaknya zaki membawa ikan maguro.

A: Maguro 1.20m lebih. Dari temen dari kapal (Temennya pak Anton). Ada temen nelayan. 30 kg Maguro. Masih beku. Bisa buat sashimi. Jumat dateng aja kesini. Waktu itu 200 ekor ikan kembung (dateng). Itu tiap jumat makan ikan terus. Bosen ngga? Ngga soalnya seminggu sekali. Tapi yang masaknyanya bosen. MIT minta anak2 hadroh untuk tampil tapi ngga bisa soalnya hari kerja. MIT bakal ngadain Maulud Nabi (sehari setelah hari wawancara ini).

(012456) Intermezzo cara motong ikan. Sama lanjut ke menerangkan gimana si ikan maguro bisa kesini. Janjian jemput di kumagaya sama mas anton dll.

(012912)

Q: Pak jadi schedule masjid nusantara dalam seminggu itu?

A: Jumatan jam 12.30. Disini jam 12.00 baca surat al kahfi. Terus baca alquran satu ain. Sekarang udah mulai masuk surat al imron. Semua **jamaah kita kasih alquran. Al Imran ayat 52** sampe sekian. Kita ngaji bareng2. Waktu itu ada org Malaysia nanya. Kenapa harus begini? Karena mungkin dimesjid lain ngga seperti ini. Ya ngga papa kan namanya juga ngaji. Akn ngga karaoke, ya ngga papa juga cuman jangan disini. Nah kenapa itu waktu itu imam besar kita Pak Haji Dadang, waktu itu ke Marocco. Dia sholat di masjid disana begitu. Itu oleh2 nya. Eh bagus loh disana ngaji dari depan satu ain tiap jumat. Jadikan kita nanti khatam balik lagi.

Hari sabtunya. Anak2 kecil gini, paling kecil 3 tahun, TPA belajar ngaji. Saat ini yang paling besar 13 tahun. Ya yang ga bisa Bahasa Indonesia juga ada, yg cuman bisa Bahasa Jepang. Tapi belajar ngaji.

R: Bulan puasa kemarin banyak bgt yang kirim beras, kurma segala macam. Dateng dari luar

Tokyo, pake takyubin.

A: Sabtu malem yasinan, kalo disini dari jam 20.00 sampe jam 22.00. jadi maghrib bersama, isya bersama terus makan. Abis makan santai2. Terus 20.00 yasinan. Minggu kosong.

Q: Kelas di manage sama siapa?

A: TPA ada tim. Timnya dari kabukicho, temen2 kabukicho. Pengurus yg di kabukicho. Kepala sekolah (TPA) nya Solahuddin (S3) waseda. Kepala TU Mba Sintia, yang ngurusin daftar2. Tapi ngajar juga. Sintia itu S2.

Q: Yasinan dimanage oleh siapa?

A: Itu natural sih ya, cultural. Jadi ngga usah di manage gimana2. Jalan. Ada yang biasa mimpin. Kalo di kabukicho mas Solahuddin. Klo disini (nusantara) mas Bobby. Lupa aku S3 dimana. Dari UIN ciputat. Mahasiswa juga S3. Kalo mas Solahuddin itu, imam kabukicho, klo disini (nusantara) imam besarnya Pak Haji Dadang.

Q: Berarti yang jadi imam sholat jumat itu?

A: (Pak haji dadang) Iya. Tapi kalo lagi ada ustad yg kita datangkan dari Indonesia ya ganti2an. 3 bulan kontrak. Kalo bulan2 biasa satu org doang. Klo Ramadhan itu 2 org untuk kabukicho dan disini. Dari Indonesia. Kalo yang tinggal di jepang susah malah pada kerjakan malah repot nanti. Full time (Ustad).

Q: Tempat wudhu itu gimana bikinnya?

A: Itu (bentuknya seperti itu) menyesuaikan karena dibawahnya ada meteran gas. Makanya ya udah yg atas ditinggiin, disesuaikan. Nggak, kalo daiku kan kayu, kalo itu kan plat yah. Kita pesan. Iya custom. 60000 itu. Yang dikantor juga custom. Yang anak2 tukang kayu yang bikin mimbar, peredam, (lantai, karpet). Wall paper.

Kenapa sajadahnya kecil2 seperti itu, karena kalau sejadahnya lebar orang cenderung kakinya ngangkang. Sejadah kecil kan mau gam au. Jadi ketika saya buka ini (masjid) udah ada yang daftar. Saya nyumbang sajadahnya ya. Gitu.atau nyumbang karpetnya ya. Atau saya nyumbang sound systemnya ya. Nah sound system itu dari pak haji bambang. Namanya (istrinya) michie san. Istrinya yang lgsg bilang, 'pak anwar saya yang nyumbang karpet'. Enak aja, karpet pahalanya gede kan tempat sujud. Itu kan jatah saya, hahaha di becaandain gitu. Yaudah akhirnya spiker kan dipake buat imam, khtubah. Orang2 deket aja yang saya kasih tau mau bikin masjid lagi. Ngga minta duit kemana2 ngga. Saya lagi belajar persis paling tidak kiai2 di pesantren mereka ngga ada yang minta2. Sampe saya yang gregetan. Apalagi ada banyak yang mau ngasih dari partai politik atau pemerintah. Tapi ngga mau. Bisa2nya dia aja. Tapi jadi. Bangunannya jadi gede2. Tanah ntara tetangganya sendiri yang ngasih. Nah gitu nah saya begitu. Karena ini kan NU, artinya spesifik kan, saya gam au ngegaungkan tapi mereka ngga tau ini NU terus mereka ngasih. Ntar kecewa. Bahkan ada yang, pak ini ada tamu saya mau sodaqah. Tapi ngga mau dia ngga suka, takut ama islam nusantara. Ya ngga papa juga. Terus maunya kemana. Muanya masjid kabukicho. Lebih lagi saya bilang. Kan Pembina nya saya juga. Rok mini banyak disana tapi ngga saya teriakin kafir. Kek gitu kita terang2an. Makanya orang2 terdekat aja. Ngga mau saya. Orang boleh aja ngga suka dengan NU, denga islam nusantara itu masing2 orang. Ngga bisa melarang orang untuk suka atau ti-

dak suak itu mereka punya persepsi masing2. Yang jelas saya cuman mau nunjukin kalo saya yang bikin masjid. Kalian apa pun alirannya boleh masuk. Tapi kalo golongan kalian yang bikin masjid pasti kamingga boleh masuk. Karena ketika tahlilan dibilang sesat. Kan ga boleh berarti. Sedangkan klo kami org syah mo masuk, masuk aja gih. Asal jangan kamu yg jadi imam. Gitu doang. Ada org syah juga pernah. Kamu siyah saya sunni. Tapi ketika sholat saya yang imam. Walopun ilmunya lebih tinggi ya tapi, karena saya ngga ngerti. Bukan saya fanatic, saya ngga ngerti pola sholatnya syah. Kita ngga pernah tau kok, dimata Allah bisa jadi dia yang diterima. Ya kan. Makanya NU itu dibilang moderat lentur. Ngga boleh kita manggil orang yang Kristen itu kafir. Ngga ada haknya kita. Loh di Alquran kan ada. Bisa jadi keitka menjelang dia meniggal dia yang mausk islam. Kita? Bisa jadi kita yang kepleset. Makanya itu yang akhirnya bikin saya suka dengan NU. Kalo di NU tuh adem, kiainya ngga banyak ribet. Khilafah bubar tahun 1924, bapak usmaniah terakhir, NU berdiri tahun 1926. Artinya kiai kita pendiri muhamadiyah, kiai hj ahmad dahlan, dengan kiai hasyim ahshari ini kan bergurunya bareng. Nih ke Mekkah. Berarti kan ketika itu jaman khilafah kan itu. Berarti mereka kan ngerti tentang khilafah.

Nah kek gitu2. Malah kejauhan.

WAKTU IKUTAN YASINAN DI KABUKICHO

(Perkenalan Ustad Idris)

Beda 3 tahun. Jadi dari SD, SMP, SMA, dari pesantren. Ternyata kuliah di pondok pesantren, setelah itu ditugaskan ke pondok pesantren di Maluku. Setelah itu saya kira sudah tidak di pesantren lagi tapi Alhamdulillah masuk pesantren. Jadi sebelum kesini saya di pesantren Al Hamid. Jakarta Timur, mengajar Quran disana. Ya semoga saya dengan didekatkan di pesantren, semoga ini mungkin jawaban dari Allah atas doa-doa saya semoga senantiasa dikumpulkan bersama org2 solehah.

(Ceramah)

Ketemu, mba Sintia yang bantu2 di Angkringan (OASIS, event di Tokyo 8-10 november 2019). The Kokom. The Kokom : 'Dateng aja kesini. Kalau cari masakan Indonesia mah pasti ada.'

Pingin tanya2 kepanitiaan organisasi.

Mba Sintia dan Teh Kokom :

Aku ga tau pokonya bagian ngitung duit ajah. Ga da jabatan sih. Sebetulnya Ka Irfan (Suami Mba Sintia). Baru ganti kepengurusan mba, ka jadi waktu dulu kana da yang senior. Sekarang diganti sama yang muda-muda. Jadi baru ganti yang muda2. Jadi sebelumnya (yang senior itu) Pak Dadang, Pak Anwar. Baru bulan Agustus kemarin diganti ke Mas Arif. Terus, Mas Arif Ketua DKM di Kabukicho, Yang Nusantara beda lagi. Jadi ketuanya, aku(Mba Sintia) disuruh bantu itung-itung duit, bikin laporan. Terus suami aku jadi sekretarisnya. Terus sama ada imamnya juga, yang muda juga dia lagi S3 di waseda. Pak Salahudin, Imamnya. Imam yang pertama Pak Mahmud. Pak Mahmud tinggal di Jepang istrinya orang jepang.

Dulu yang ngurus ini(masjid kabukicho) pertama itu Kakek Idris. Kakek Idris ini umurnya udah 85. Pertama yang mendirikan, wartawan. Masih sehat, udah 45 tahun di jepang. Bolak balik ke

Jepang tapi akhir2 ini lebih sering ke Indonesia. Paling di jepangnya beberapa minggu atau hari. Kalo romadhan, nyari lailatul qadarnya disini.

(Intermezzo) Mas Sulis, kenshusei yang baru satu tahun di jepang, ketemu pak Mahmud di restoran Bintang Bali kemudian beliau ngajak bincang2 dst. Pertama dia tau saya santri bahwa nanya tempat datu Indonesia, soalnya waktu di pesantren ngga pernah keluar jadi kota2 lain ga tau. Terus saya bisa kesini ketemu sama orang yang mukhlis.

DAVI NOTE: Bikin masjid di Tokyo sama di Indonesia itu kan berbeda ya. Mesjid itu kana da dalam keseharian, sedangkan disini kita minoritas. (Teh Kokom) membawa umat itu susah disini. Iya pencar2. Tadinya saya mau pelajari bentuk bangunannya fisiknya. Karena kalau di Indonesia cenderung punya tipologi bentuk tertentu, yang ada pakemnya mau di Kampung mana mesjidnya kayak gitu. Nah terus kalo disini kan emang pada dasarnya negara bukan budaya Muslim jadi mereka ga pernah punya ada perkiraan ada buat orang sholat segala macem. Sehingga gimana tadinya kita yang punya kebiasaan ruang kota yang ada mesjidnya ruang komunal mesjidnya itu pada saat tinggal di Jepang bagaimana di reinterpretasikannya. Nah emang kita sekarang bentuk bangunannya kan kebanyakan bukan yang Indonesia aja ya. Mesjid2 yang kayak Pakistan dan Bangladesh kan sebenarnya dia kan juga make bangunan yang udah ada di Tokyo. Kalo dipikir2 secara datar kita kan di Indonesia masjid satu lantai luas terbuka, orang bisa masuk dari mana aja. Tapi kalau disini kan tiba2 jadi kerucut keatas. (Teh Kokom) Kan beda kultur beda negara jadi kita harus memaklumi yang disitu.

Saya ingin mempelajari gimana sih persepsi terhadap ruang masjid itu sedikit shifted, berubah dikit lah di Tokyo ini. Sehingga kalau di Indonesia mah kalau dalam kampung se RT juga bisa ke masjid juga bisa ngumpul ke rumah juga bisa. Silaturahmi. Habis sholat id kan dirumah dll. Tapi disini kek masjid itu jadi pusat buat orang2 ngumpul juga. Ada pertemuan, nilai tersendiri. Keliling semua mosque yang ada di Tokyo, yang Pakistan, yang Bangladesh, yg di Hachioji dll. Terus ngerecord bentuk2 bangunannya. Sama nanyain kegiatannya apa aja. Sama gimana sih organisasinya, gimana sih hubungan orang2 yang membentuk ruang masjid itu gitu. Keknya tiap komunitas punya beda.

Di Kamata lebih strict pemisahan cewek cowoknya.

Kalo Imam itu tugasnya ngapain aja?

Mba Sintia: Sebenarnya kalo dari fungsinya emang iya ngimamin sholat, tapi ngga berarti yang ngimamin sholat cuman dia doang. Cuman maksudnya seperti apa ya. Orang yang kita unggulkan dalam hal agama lah. Kek ketua DKM itukan mesti orang (usatah?). Kalo di Indonesia kan ketua DKM adalah orang yang ngerti agama juga, disini kita kek semacam ngebedain kalo urusan management, itu yang ngurusin ketua DKM. Tapi kalo urusan keagamaan yang ngurusin itu imamnya. Kek semacam, ada acara yang ngeduluin misalnya. Mau ada maulid misalnya, pasti org yang pertama kali ngingatin itu imamnya. Tingkat keilmuan agamanya lebih tinggi makanya kita pilih dia. Yang nentuin siapa jadi imam itu sekretaris. Tapi rata2 sholat jumat tuh selalu imamnya. Baru nanti kita pikir khotibnya. Khotibnya kan selalu dari Indonesia. Itu juga ganti2an. Tapi rata2 kalo imamnya sholat jumat itu mas salahudin (imamnya). Soalnya juga susah nyari imam. Soalnya

banyak kesibukan, Kek orang pak ustad, Pak ustad kan berarti ibaratnya ilmunya tinggi tapi kan beliau ngga selalu tinggal disini. Jadi kayak ada suatu jabatan, otomatis orang itu lebih bertanggung jawab atas apa yang dia lakukan dalam artian berarti semua perihal keagamaan berarti tanggung jawab kamu. Ketika ada Maulid, Imam harus orang yang paling ingat. Dalam hal ibadah. Tersu misalnya kok acaranya kita tahlilan aja ya ngga mau tambah wakiah ngga? Kek gitu. Jadi dia udah ngga ngurusin duit kita berapa dsb. Maulid itu yang ngurusin DKM. Dalam keagamaan imam. (34:00) Perseptif kebanyakan orang Indonesia masjid itu yang ada kubahnya. Kalo misalnya masjid harus bangunan yang berkubah. Dari situ aku mendapatkan suatu teori, dalam artian, kita itu, shifting mind dari pada aku dari Indonesia dan aku disini itu ngerasa aku baru tahu define dari masjid itu adalah bukan dari bentuk ruangnya tapi dari fungsinya. Kalo disini (dijepang) masjid udah bukan lagi sebagai bangunan, tapi udah sebagai fungsi. Jadi mungkin rumah aku bisa jadi masjid ketika aku jadikan fungsi itu sebagai masjid. Dan klo di Indonesia, bisa dibilang kita ngga akan pernah menyebut sebuah bangunan yang ngga berkubah itu sebagai masjid. Makanya pas mbak cerita itu yang sebenarnya aku alamin pribadi. Dimana aku mengalami shifting mindset ketika aku dari Indonesia pergi kesini terhadap apa bangunan masjid itu. Menurut aku itu penting bgt ketika di Indonesia orang ngumpulin uang sebanyak itu agar bisa ngecor kubah misalnya biaya yang tinggi ngecor kubah di Indonesia, ayah ku kan ketua masjid di Indonesia. Jadi kayak kita tuh, dulu ayah ku ada satu perumahan, perumahan sss. Ada fasum. Disitu ayahku inisiasi buat ngediriin masjid, nah disitu berdiri karena kita masih belum punya uang sama ayahku tuh biar target Ramadhan itu jadi ya udah tutup aja pake seng, nah orang itu tuh kayak masih menganggap kalo misalnya ngga kayak gitu tuh bukan msejid. Nah itu tuh aku ngerasa, orang Indonesia itu masih berpikiran bahwa bangunan suatu arsitektur masjid itu adalah hal yang penting, lalu ayah saya mikir berusaha biar orang bisa nganggap bangunan tersebut masjid. Sampe akhirnya beli kubah kecil buat nandain itu masjid. Karena orang ketiak ngga ada itu ngga nganggap masjid. Itu pemikiran orang Indonesia kek gitu. Kalo di Indonesia arsitektur masjid itu penting, tapi kalo di luar negri itu ngga penting.

Teh kokom : Tempat susah, bukan soal arsitek, apalagi. Gimana mau ngarsitekin mereka ngga bakalan terima, dulu aja di Meguro mawarinya ngga ngijinin, berisik aja dibilangin.

Davi: Kamata jendela di tutup, peredam. Sedangkan di Indonesia kita itu hidup dalam kota yang suara adzan berkumandang, melingkupi semua kota nah itu tuh suara itu salah satu aspek yang mendefinisikan atau yang membuat kita tuh mengetahui seperti apa ruang yang kita tempati terutama di kota. Pada saat kita dateng dimana dalam keseharian itu kita ngga denger suara itu lagi, nah itu tuh udah berubah banget. Nah suara2 itu datang dari masjid, aku mikirnya, apakah sebenarnya bentuk dari peredam kebisingan dll itu adalah perubahan dari dimana tadinya kita bebas mengumandangkan suara adzan segala macam itu tapi pada saat Tokyo atau lainnya, itu harus diredam. Tapi kita tetep ingin mempertahankan suara dalam berkegiatan ibadah, nah tapi kita bertoleransi juga dengan lingkungan yang kita tempati, Sehingga al hasil dalam arsitektur diwujudkan dengan double jendela. Nah itu juga pas yang di masjid nusantara tadinya kan jendela yang dibelakang, itu kan dijadiin peredam. Jadi pada saat renovasi bangunan itu kan jadi kom-

promi. Bisa aja ngga ditarok peredam karena sekeliling menyetujui, bisa aja itu tetep jadi jendela. Cuman pada saat ada limitasi bahwa kita tidak diperbolehkan, limitasi diwijidkan dalam bentuk. Mba Sintia: Ada yang unik mba di kabukicho, di kabukicho kan ga ada peredam, kata pak Anwar pernah didatengin sama orang masalah itu, terus jawabannya, kan kita rebana juga, itu kan berisik terus katanya pak Anwar. Kabukicho kalo jam 11 ke atas banyak tempat DJ. Berisik. Terus Pak Anwar jawab, mereka aja boleh bernyanyi, nah ini lagu kita gitu. Tapi kan daerah ini kan memang daerah hiburan sih. Kalo normally harusnya pake peredam suara. Yang di akhabara juga kalo adzan masih ngga papa. Tapi kalo rebana yang agak gede suaranya.

Asakusa Mosque Interview

(Interviewee, Kazafiさん)、12/19

D: モスクはいつ建てられた?

K: 23か24年前です。(1995年)

K: これは建物をそのまま使っている。建てているんじゃない。なんか昔は会社だったんですよ。ここは。会社で昔、そのままに買った。

D: モスクの前はどこかでMushalla とかはありましたか?

K: そのときは何もなかった。(誰が?) 誰かは22(?)年前の人たちが、今はここにいないんだけど、私も後から来ているひとなんだけど、そのときその人たちがほかのどこに移ってたりとか、パキスタンに帰ったりとか、まあたまに来る人もいるんだけどその時はここでやっぱりまわりに人がいっぱいいて、でモスクがなかったから、でそれでみんなでお金を集めてでこの場所が一番お金的にも駅も両方あるからそれを考えながらここを決めたんじゃないかなと思います。

D: 次はここを回収したのはだれなのか?あとどのようになかのしつらえを決めたのか?

K: ここを買ったときはまずこの建物買ったのはそこの組合があるんですよ。ICOJという。Islamic Circle of Japan. その組合が色んなところでモスクを作っている。ここが一番最初だった。そのあとはHiraaモスク(行徳、千葉県)と大山と栃木県と色々あるんですけども、一番最初はここです。大山市、栃木県あそこもあるし、Hiraaモスク行徳、千葉と群馬県まあ全部でたぶん10個ぐらいですかね。

D: 建物の建てるときは大工さんとかですか?

K: その建物を買ったあとに自分で直したんですよ。まあもちろん少し業者の人もいたんですけどほとんどは自分でやったんですよ。

O: まあ専門的な部分とか業者さんにやってもらったんだと思うんですけども。もうなんか普通に壁を壊すとかそういうのは多分みんなが多分当時のひとたちが手伝ってやっとな。まあもう20何年前の話なんですけど。まあその時はみんなで作ったんですよ。

D: 部屋や施設はどんな物がありますか?

K: 一階は図書館。一階は本当は図書館なんだけど今家がリフォームしたあとまだ戻ってないんですよ。もとの。今ここ全部リフォームしたんですよ。したばかり。まだ半年もなってないですよ。でまだ一階おわってないんですよ。

O: だからまだ一階何もできてない。まだ工事中。

K: 昔は図書館だったんだけど、また図書館つくるんだけど、その工事の人がなかなか時間がなくて作れない。だからとりあえずだけはその壁に本当はそのうらに全部棚があるんですよ。その棚に全部本があるんですよ。

D: さっきはリニューアルっていったんですけど、その24年前は買ってただけ?

K: そのあと我々私たちが今の人たちが自分でこれリフォームした。まあ業者に頼んでお金を集めて、自分でお金を集めて1-5階からここ本当は建物の中に水が入ったんですよ。も古くて。雨漏りとかしてたから、塗装も全部ふるい。これ全部(新しく)塗装したんですよこれ。まだ工事おわってないですよ。本当は。個々の部分とかまだ全部まわってないんですよ。

D: 何年ぐらいにリフォームをしたんですか?

K: だからちょうどその買った後に一回リフォームして去年か今年ぐらいに終わって。ちょうど2年とか23年の後にもう一回リフォームした。一回リフォームして、その後2年かけてリフォームしたんですよ。

なのでだから一階が図書館で、2階が女性、で3階が男性で4階がミーティングルーム今ご飯食べる所。で5階がここのイマームの家、家なんですよ。

D: 下の階のHalfフロアの部分はなんですか？

K: あの二階の所が事務所なんですよ。ICOJの事務所です。

D: 敷地はだれが選んだんですか？

K: その人たちは今ここにいないんだけど、千葉とかほかの所に引っ越した。例えば一番最初にいた人たちがJamilさん、という人。Seraajeさん、みんなパキスタン人です。IsrajさんとあとSaeedさんとあとArifさんと大体10人(最低20人)ぐらいの人が周りにいた(住んでた)人たちがここを買うというわけです。一人か二人ここにたまに来るけどね毎週とか来るんだけど、近くには住んでない。国に帰ったり東京の外に行ったり。埼玉とか栃木のほうとか茨城とか。

D: キャンパシティーはどういう感じですか？

K: 60-70人ぐらい(男性礼拝所)。

D: 女性は？

K: 女性は同じじゃない。(男性礼拝所と)あそこはここのスペース(壁の裏)はないから。

O: 40-50人ぐらいだとおもう。ざっくり。

D: Jemaahは何人ぐらいくる？

K: 大体40-50人ぐらい。たまには多いときもありますよ。例えばこれから休みがあるでしょ。あのお正月。その時は4階までみんな上がっちゃう。そのときは70-80ぐらい。女性の所は女性のままでけど、例えばラマダン中とか一階も使うんですよ。

D: ラマダンの時は1, 2, 3, 4階という感じですね。

K: そうそう。毎週日曜日だけみんなここにくるんですよ。Iftarの時間で毎週毎週日曜日。そのときはもう全部一階から4階まで。

O: まあ休みの日だからね人が集まりやすい。来られやすい。

D: 活動はどうですか？

K: ここは毎週はJumaahでしょ。土曜日の夜はここで集めてQuranの話Darusね。で日曜日は子供たちが来る。Quranの勉強私の子供たちとか他の人の子供たちとかあの、2階日本人の女性がQuranを教える。で4階はイマームさんが、男の人たちが4階で。で女の人たちが3階で女性たちが教える。それが大人のクラスもあるし、子供のクラスもあるし。あと日本人たちが一か月で、第三か第四にみんな来て、でその時はQuranとHadistの話し。日本人の奥さんたちが来るんですよ。昔は多かったんだけど、最近は多くないな。5人か6人ぐらい。で子供みんな入れてまあ10人ちょっとぐらいかな。でみんなバラバラ来るんですよ。まあ私は知らないけど、自分でなんかプログラムつくってるんですよみんな。だから大きい子供たちは第二とか小さい子供たちは第四とか、そういうプログラムで3回でそのグループであるから、女性たちに。で4階は毎週日曜日に子供たちが朝から夕方にかけて来る。

D: 女性はの3階でやっているんだけど。

K: もちろん昼間にやってるから。一か月で三回ぐらい。毎週の日曜日。それで第三と第二と

第四で。時間は私あまり知らないけど、まあだいたい、お昼から夕方が多い。Dzuhurからあの Maghribの間。

D: 女の方が三階で男の人が4階。でもお祈りの時は？

K: もちろんお祈りときは、女性は3階でお祈りして、男性は4階で。

K: Darus, Jumaahでしょ。ああそう。毎日IshaのNamazの後に大人の5分ぐらいのQuranの勉強がある。それは毎日。Ishaの後だいたい5分ぐらい。

O: 平日

K: それが毎日。

D: Eidはどんなことをやりますか？

K: Eidの日はまずまあ大体150人ぐらいくる。でそのあとにご飯を食べるみんなで。4階と5階(三階?)は男性で、二階と一階は。二階はいつも男性(女性?)だけなんです。一階はあまり使っていないけど。Eidのあとにご飯たべてみんな話しながらお昼までにここにいて、そのあとに帰る。

D: 女性と男性は食べる時分かれていますか？

K: 分かれていますもちろん。

D: で下の階とか使いますか？ごはんは。

K: 多いときは使うけど、でも大体いつもは使っていない。女性はいつも20-30人ぐらい。

O: いつも女性はその2階でいつもなんとかできる。ごはんももちろんそこで食べるということ。

K: いつもは上からごはんを下に持ってきて、女性はそこで食べてる。2階で。

D: ごはんはどこで作ってる？

K: ごはんはだからまあ、外から作ったり。まあたまに上から作ったりとか。上にキッチンがあるから。たまに作ったり、あとはレストランとかで頼んで、作ってもらって。

D: ラマダンの時にどんなプログラムがありますか？

K: ラマダンのときに特別なプログラムはないけど、もちろん毎日5回のお祈りとそのあとに Taraweehやるんですよ。ここは毎日Iftarもやっている。だれかが周りに住んでる人たちとか後観光客たちがここにIftarに来るんですよ。Seherもやってるんですよ。(観光客も来るから) Iftarのときはちゃんと用意してあるんですよ。Sahurもここでみんなやる。

D: 料理はだれがやっているんですか？

K: 誰がというのは決まってない。それは決まってないけど、まあいる人たちが、まあほとんどはレストランからとか。

D: モスクを管理してる人は？

K: モスクを管理しているのはこの組合がいるから。10人ぐらいいるから。ここは一か月一回ミーティングをやるんですよ。でそのときみんなお金のこととか、電気代ガス代イマームさんの給料とかこの税金とか。これ全部いくらになってるか。今責任者いないんだけど、パキスタンにいったけど。その責任者がみんなを呼んで、みんなここで、あと銀行の通帳をみんなの前で今このぐらいお金で今月、例えば今月30万使った。であつまってお金は25万とか30万とかそういうあれでこの管理やってるんですよ。みんなで。

O: ここはみんなが動かしてるって感じなんですよ。

K:だからもちろんお金はみんなで出したり毎月例えばきまってるんですよ。5千円とか一万円とかその人たちもお金入れてるし、あともちろんBoxとかあるでしょ、そこから出てるお金で、ここの管理をやってますよ。なのでみんなのお金でかんりしてます。

D:さっきクラスとかがあるがその教えてる人達は決まってる？

K:それはだれかが決まってないけど、例えば4階はもちろんイマームさん男性は決まってるけど、4階(3階?)はちょっと変わったりするんですよ、遠くから来る人たちもいるし、あとインドネシアの先生と日本人の先生二人がいるんですよ。その二人が自分で時間合わせてやってるんですよ。決まってるってわけではない(Not fix the schedule)

K:日本人の女の子先生がとあとあのインドネシアの先生。それはボランティアでやっています。

D:クラスの時なんですよけども、何か机とか使ったりしますか？

K:まあ多分つかってるんじゃない？二階にもこういうのがあるから。(Short long table foldable) QuranとなんかHadistの本とか持ってきて先生が教える。

D:Imamは？

K:Imamは一人だけ。パキスタンから来ました。5階に住んでいます。Jumaah とKhotabahと毎日の一日の5回のお祈り、だからずっと一日ここにいるんですよ。

D:普段モスクに来ている人たちはどこら辺にすんでいますか？

O:いやあ、もうみんなバラバラですね。

K:てか私はここから5分ぐらいに住んでる。もう一人は5分ぐらい。で二人(インドネシアの人のほう)は20分ぐらい。で彼は(Oさん)は越谷から、埼玉から来てます。30-45分車で。だからバラバラなんですよ。

D:学生か社会人の割合わかりますか？

O:それはNamazとかのときとか？

D:Namazとか勉強会に来る人たちとか。

O:ううん大人の例えば今日みたいなところは学生はいないですね。

K:たまにしか来ない、日本人の人ひとりいるだけだね。学生。あとパキスタンの人も学生がいるんですよ。二人か三人ぐらいかな。パキスタンの人と日本人のひとで合わせて。で三人ぐらいかな。

D:Nikahとか葬儀は？

K:やっています。先週もやってよここで。ここやっていますよもちろん。そ、電話かかってくるときにNikahしたいときはちゃんと家が女の子と男の子の書類をまず電話で教えるんですよ。まず電話で全部教えるんですよ。例えばね、国籍(?)とか、パスポートとか外国の人だったら、これ全部持ってきてもらって、Imamさんが全部見て書類が全部取れたらそのあとにここで例えばMuslimじゃない女の子がMuslimにしてからNkahして、二人ともMuslimだったらまあ。Muslim Certificate とNikah Nama(?)ここで出してるんですよ。

D:葬儀は？

O:昔の時は知らないけど、最近聞いたことないかな。ま、ここほとんどっていったらパキスタン人が結構集まってるんですね。まあ例えばそのなくなったっていてもまあみんなほとんど国にかえっちゃうんだけど

K:帰っちゃうんだけど、たまにね去年に一人このパキスタンの人がなくなっちゃって、家の友

達がでその人が一階にあるんですよあの洗う所が。そこで洗って、お墓は茨城県。たまにしかない。ほとんどの外国の人が国に帰っちゃうんですよ。ま、大塚とかHiraaとかあるんだけど、ここはないってことはないんですけど、わたしがいたときも2か3回ぐらいあったんですよ。この2-3年のなかで。一階にあるところありますよ。Kafanもあるし、洗うものも全部そろってあるんですよ。それ全部事務所においてあるんですよ。だから急に来た時も全部そろってあるから。で一階でJenazahもできる。(Shalahもそこでやる)

D:改修について確認

O:別に閉じてた分けではないんですよ。ちょっとずつやりながら。

K:外回りと中回りやったんですよ。塗装。やったんですよ。

D:前あった施設で今はないってのはありますか？

O:それはないですね。

O:そのままです。二階は前から女性のも今も女性のもままですし。それはそのまま。

K:だから変えたりはしてない。ほとんどは塗装がはがれちゃってあとひびがはいっちゃって、あの地震もいっぱいあるでしょ。それを全部なおしてもらったの。

D:これからのモスクの方針はありますか？

K:まあだからこれから、毎月ミーティングをやるときは毎月新しい(意見)をみんなから聞いてこれからどうすればまわりにいるMuslimたちやNon-Muslimのひとたちでもモスクのどうやって来れるか。それはもちろん毎月はみんなで話ししてる。だから一階はちゃんときれいにして図書館作ったら、でMuslimじゃなくてもみんなが入りやすい。でなかで本とか全部。家ね大体ほとんどあのQuranも全部のLanguage日本語とかあのBangladeshとかRussiaとか全部の本そろってある。だからあのまだ始まってないけど、始まったらまただれでも来るようにしてる。まああそこはラマダンの時は、一つだけのIftarパーティはNon-muslimのIftarパーティなんですよ。そこは本当にNon-muslimだけの、まわりのみんなにパンフレットを配ってる。で自分が一人日本人あの食の関係とかみんなを呼んでるのここに、でモスクのことみんなにおしえる、紹介する。ここは毎年やっている。でそれがあとこれからもおんなじようなまあそういうパーティみたいのいつもプログラムを作っている。まあなかなか時間がないんだけど、今だから新しいホームページを作って、昔はあったんだけどでももうないから。だからあのこのモスクのホームページ作ってFacebookにもここにMuslimたちが多分オリンピックもあるから。今もやっぱり毎週来るんだよバス。観光バスくるんだよここ。観光の会社がこのモスクの連れてくの。絶対に。

O:浅草が観光地だからそれで近いから。

K:そのバスはみんながお祈りしたいときはみんなここに来る。たまに毎日のときもあるんだよ。今日も来たの。何人かくるの。マレシアとかインドネシアはどうしてもお祈りしたいじゃない。そうするとやっぱり来る。でそのバスの人たちがもう知ってるから、Muslimの人たちがどこどこいって。だからここにもくる。

O:浅草は今結構ハラルも結構店いっぱいあるから。だからそれでたぶんMuslimの観光の人ここに来てるから。その関係上で結構このモスクは。

K:だからホームページを作ってもうちょっとみんなに情報届くように。

D:上にあるMinaretはだれが?

K:あのね、あれ鉄でつくってるんですよあれ。自分でパキスタンの人が作ったの。鉄を一個一個持ってきてよせて(?)ボルトでつけて。もちろんこの建物はモスクじゃなかったから、それでパキスタンの人が20年前に作ったんだ。みんなで作った。あれはパキスタンの人がやったんだよ。

ここの建物を宗教法人に出しているなので毎週写真とか取っている。

Hachioji Mosque (11/11/2019)

Mr. Khotaiabah (Mekh Adzan)

建物:

Q: いつ頃建てられたのか?そして誰が最初に建てたか。

K: これは19年前にできた建物。それ以前サウジアラビアのある商人がこの土地を持っていた人。Al-Jureesiさんという人。今も彼の名義になっている。彼が買った土地であんまり使う道がないのである宗教グループがこれをモスクにしましょうという案を出した。

Q: その宗教グループというのはわかりますか?

K: 宗教グループより有名な先生Prof.Saad Al-Bureikhという先生がそういう案を出して。で向こうはAl-JureesiさんがOKしました。当時のサウジアラビアの王様はKing Faad国王で当時の息子はAbdul Azizが彼のお父さんを通じて色んな国々でモスクを立てた時期があった。はっきりしたデータは持ってないけど、多分スペインとかアメリカとかヨーロッパとか世界の色々な国でそういう色々なプロジェクトがあったんですよ。であの、そのAbdul Aziz,Faad国王の息子さんがこれを立てるためのお金を出してくれました。で建物の名義はSaad Al-Bureikh先生。Saad Al-Bureikhはイスラム弁護士なの。あとモスクのイマーム向こうのサウジアラビアのRiyadhの。でそういうルートでここができたんですよ。でちょっとモスク立てたのはありがたいですけど、不便なのは今宗教法人として登録ができてない状態。なぜかというと、土地の持ち主と建物の持ち主と連絡が取りづらい。みんな忙しいから。Al-Jureesiさんが土地Saad Al-Bureikhが持ち主。宗教法人に変えるための色々な条件はもう私たちは満たしている。活動とか。でも彼らの同意と同意の仕方とかプロセスがあんまり私たちは素人と彼らのその名義をどうやって取ったらいいかも、ちょっと不便。遠いところにいるからあんまりたどり着きにくい。二人ともサウジアラビアに住んでる人たち、遊び心でこの土地を買って。

そして最初にこの地域にはイスラムの人があんまりいなかった。でも今から、15年たってから人が住むようになった。あと西八王子にも日本語学校があって、Uzbekistan系の人たちとか、インドネシアの人たちとか、後大学も色々近くにある。ソウカ大学とか中央大学とか、だんだん人が来るようになった金曜日にですね。ほかの日は一日お祈り五回なんだけどほとんど人が来ない。一人か二人しか。後夜も仕事があって来れる人は大体5人から10人夜の五番目のお祈りIsya。で日曜日には私の妻がボランティアで女性と子供たちにQuranとアラビア語を教える。あと金曜日の午後も教える。地域の人たちに。日本人、ムスリムではない人たちに教える。MaghribとIsyaの間。日曜日はね。そしてあのアラビア語教えますね、金曜日の16時ぐらい。今日は教えなかったのは子供が予防接種を受けるためにちょっとキャンセルしました。そしてあのもちろん宗教法人として登録してないから結婚の登録はできない。でもたまたま、宗教法人イスラミックセンタージャパン。世田谷にある所と結婚書類ここで作って向こうで押してもらうとか。向こうは宗教法人ですから。私たちが向こうの書類をかって押してくれる。正式な資料もらって、悪魔でもすべて向こうの書類と向こうの印鑑とここで私たちが代理で書類を作っている。これは結婚の場合でもあんまり一年に一回あるかないかぐらい。あと色々な大学とか前は大学グループが大勢来てました。13年前。先生が例えば、日本人とかアメリカ人の先生もいた青山大学の。イスラム文化とかイスラム地域研究をする人で生徒を連れてここでレクチャーを聞いたり私たちが説明したり。していました。あとあの現在このイマームは日本の国籍

の人でお父さんがパキスタン人でお母さんが日本人。Omeir先生。

人間：

Q:誰がどういったポジションをもってモスクを管理してるっていうのがありますか？

K:宗教法人として登録してない組織で、悪魔でもこの人間はボランティアが多い。例えばパキスタンのSaleem Bakhtiは、彼はマネージャーなんだけど形だけですね。もう本物の最高責任者はあのAl-JureesiさんとSaad Al-Bureikhとサウジアラビア大使館。でサウジアラビア大使館もこういうマナー的にモラル的にここを見てくれる、スピリチュアル的に。あんまり直接関係は正式な関係はない。(Omeir先生について)彼はガソリンスタンドでもアルバイトできるし、イマームになっても政府は何も言わない。関係ない。

イマームというのは一日五回のお祈りをリードしてくれる人。(レクチャーとかを教えてくれる人は)彼と僕とSaleem Bakhti誰が空いてるか。あと相手によってまた変わる。聞きたい人がアラビア人であれば、僕が担当アラビア語ができるから。聞きたい人がパキスタン人とか日本語ができる人は僕かSaleem BakhtiかOmeirさんだれが空いてるか。

レクチャーは金曜日のKhotbahとは違う。例えば、今日この話を聞くというのも、一つの説明、お客さんに対応するとか。(Khotbahのときは誰?)Omeir先生。今は彼は日本で男の割礼ありますよね。息子生まれたので日本では割礼すごく難しい。ないかもしれない。だからパキスタンで割礼してる。奥さんインドネシア人なのOmeir先生ね。すごくおもしろいのは今のこのインターナショナル的な世代Omeirが父パキスタン人、母日本人。Omeirの奥さんがマレーシア人。生まれた子供が三分の一パキスタン三分の一日本。三分の一マレーシアとか。日本がラグビーチームみたいに国際かしてくるのが、だからこのモスクのイスラムのFiqhとかTafsirとかFatwaとか新日本に対応するようにまた変わっていくのがハラールか何がハラームか。向こうとここは違う。韓国と中国とももちろん。そしてあのこういった柔軟性が正式な宗教法人としてではない場所にあるため柔軟性がすごくある。例えばOmeir先生がパキスタンで一か月休むとすることもできる。日本の会社だとできないでしょ。で僕みたいな人は180ページの漢字辞書、アラビア人向けの漢字辞書をここで作ることが80%ここで作れたいつも暇ですから。僕にはとても都合のいい研究の場所です。しかも子供たちが近い学校に通ってもどってお父さんが家にいることが何よりも私にも嬉しいし、子供たちにもありがたい。もどってお父さんが仕事お母さんがアルバイト誰もいないとかそういうのじゃなくて、イスラム的な組織で務めているからこそ、こういうことが出来る。もし僕が日本の会社で働いてるとしたら帰りが夜の10時とか11時とかできない。

プログラム・アクティビティ：

K:あとラマダンの時には毎日Iftarがあります。パーティ。でも人は3人から10人だけくる。でも土日は100人以上来ます。土日は正式なIftar。ほかの日は。毎週金曜日の食事はエジプト人のEsamさんという人が、彼はハラールショップのお店を持っていて、材料を寄付する人がいる。その寄付してるひとは私たちはだれか分からないです。多分ここで祈りにくる三人か四人の人たちがEsamさんにお金を渡して、Esamさんもボランティアで作ってる。彼のお店から買い物をする。ほとんど。ラマダンのIftarの食材はリストがあって土日の場合は寄付した人は自分の名前を書く。今日は私はここで調理しに来て、みんなに作りますとか。あるいは外のパキスタンの料理店からごはん、大きな鍋を持ってくる人もいる。土日つまり近いですね。毎日簡

単なものは僕のお家から出しますね。ここで個人でアラビア語の勉強をした人は対応します。2回の礼拝場では週に三回こどもたちと大人たちがQuranを勉強しにくるOmeir先生と。大体10人ぐらいいますね。ハーフの人が多い。あと毎週土曜日毎月二回目の土曜日第一土曜日と第三土曜日に家族のあつまりがある夜。決まってないけど、月に二回。で土曜日。一、二、三、四の土曜日。か分からないけど土曜日には月に二回だいたいアラビア人家族が集まる、もちろん中にインドネシア人マレーシア人が参加したい人は、でも家から料理を持ってきますね、少し。八王子に住んでる人が多い。あとインドネシア人グループとマレーシア人グループでここで寝泊まりしたい人、27日のラマダンLailatul Qadarとか大体三日か四日大丈夫ですね。それぞれ自分の小さなカバーとか持ってきて、自分の弁当とか持ってきて、ここでQuran勉強する。Quranを読んだりとか、ラマダンだけです。あと生徒たちがここ(一階のMeeting Room)を使いたい場合は無料で貸しますね。ぜひ友達連れてきてここで勉強会の機械作ってちょうだい。あと学生でイスラムについての研究がしたいとか、あと警察とか公安庁がイスラムについてとか、テロについてとか何か聞きたい時には私たちもオープンで対応します。

建物:

K: 建物は新築。川上さんという建築家が作りました。彼はサウジアラビアのRiyadhで三年暮らしたことがある人です。イスラム教に人ではない。(知り合った切っ掛けは分からない)。(施設の何が必要かを決めたのはだれ?) Saad Al-Bureikh先生とあと中央大学にも非常勤講習をやっているインドのSalim Khan先生すごく有名な先生。彼はQuran全部暗記してる先生。日本ですごく有名な学者。Salim Khan先生はイスラムセンタージャパンの一人の理事だった。Saad Al-Bureikh先生はイスラミックセンタージャパンと中がいい人。イスラミックセンタージャパンの代表理事Dr. Sari Al samarai.と中がいいので。でSaad Al-Bureikh先生がSalim Khanさんにちょっとこれができるまで川上さんと見てくれないかって。管理人だった。19年前。

Q: Wudhuの近くにある、亡くなった人を洗う場所は、最初から決められてたんですか?

K: そうですね。宗教法人として登録してないので、だからここに持ってくる意味がないのと衛星面もちょっと心配。

第二部:

K: 100%のうち、60%が学生。その中の30%がマレーシア人・インドネシア人・が多い。学生。日本人は一人か二人来るか来ないか。あと残りの40%はアフリカ系とパキスタン・インド・スリランカの人たちが多い。とすこしアラビア人、レバノンとかイラクとか。お子様を連れてくる人もいる。金曜日に奥さんがアルバイトで連れてくるとか。ほかの日は近所の子供たちが来る、Quranの勉強とか、お祈りの勉強とか。あと土曜日遊びに来るとか。いろいろ。

Q: ラマダンのTaraweeh.などラマダンだけにやる特別なプログラムとあってありますか?

K: ラマダンはまず土日はまず大きなIftar. Taraweeh も最初のラマダンから最後のラマダン。あと今日ラマダンですとか、ラマダンを行う(始める)一日の前にここでだいたい皆9時に20人から50人集まります。明日ラマダンかラマダンではないか。集まってそれを待ちながら交流したり、料理食べたり、ミルクティー飲んだり。後Eidは明日あるかないかを、集まる人もいる。後、八王子モスクから高尾山に上る人もいる。ラマダンの月を見に行く、大体曇ってて何もみえないけど、もう何十年間私たちマレーシアに合わせてる。Hilal Committeeがある。Quranの月をみるためのComiteeがあるの。毎年日本にあります。Salim Khan先生が代表。全部Whatsapp,

やメールに来る。明日はZulhijahとかMuharamとかラマダン始まりますよとか。組織の名前がRukyatul Hilal Committee. そして最後のラマダンの10日間はTaraweehだけじゃなくて Qiyaamもあるの。QiyaamはTaraweehの後に大体10時から11時までだとか、またお祈りしますね。(Eidの時には300人ぐらいくる。)お菓子くばたり、クイズやったり。お菓子とかお料理とか、お年玉も子供たちに配ります。おもちゃ配るときもある。安いもの。Eidのお祈りのイマームはOmeirさん。Omeirさんが来るまえにはまた別の地域の先生だれか探してボランティアとかも。

Q:行事は建物のどの部分をよく使うのか？

K:もちろん僕たちが住んでいる、イマームが住んでいる部屋が。行事はもう2階の男性礼拝所が多い、レクチャーとかは一階と上(2階)でもやります。2階は女性入れない。男性だけ。昔は女性入っていい。人数が少ない時。今Omeir先生はちょっと厳しい。

Q:建物の施設

K:男性礼拝所、女性礼拝所。一階のWudhuの場所。そしてお客さんの料理するためのキッチン。その前にここのレクチャールーム。本当は中(キッチンの隣の部屋)がオフィスなのででもあまり使ってない。受付になってます。亡くなっている方のための部屋はあるけど今は倉庫になっている。今はその部屋は何もない。

K:今はまだこの先何に使うかわからない。もしムスリムの人数が増えた場合。八王子にイスラムのお墓が出来た場合。お墓が難しいんですよ。その許可土葬許可が一番難しい。衛生面とか、山梨にはいくつかあるんだけど、でも八王子で土葬許可が、例えば日本のルールが五十年後100年後変わったら。もしかすると土葬許可が確実に取れるようになれば、たぶんこの建物、八王子モスクは新しくリニューアルする。そのとき洗う(亡くなった人の)所ができるかもしれない。

K:難しいだけでなくあったとしてもすごく高い。お金があっても許可が無理。0%。火葬だけ。無理に近い。

Q:モスクをどのような方向性で作っていきたいか。

K:多分これからもっと拡大してべつの所を買って多分小学校、中学校、大学レベルに所属を考えている。(学院と所属というのは)まあルールはまた政府と弁護士に夢としては、小中高、大学、専門学校作りたいですね。

将来日本にいるムスリムの子供たち、日本人であろうか、ハーフであろうか、外国人であろうか。イスラムの文化を守りながら日本の社会に溶けるように、違和感が少なくなるように方針を進めていきたい。

Q:もといた国のモスクの存在感と日本にあるモスクの存在感の違いありますか？

K:向こうにもモスクの種類がたくさんある。壁が厚いモスク、安い壁が薄いモスク。金曜日の礼拝があるモスクと金曜日の礼拝がないモスク。大きさによって、そして高級エリアに建てられたモスクと庶民的な安い年間が低い人々のモスクがある。それぞれの所によって人間の仕組みとスピリチュアルが複雑に絡み合っていて、例えば自分が貧乏で高級エリアにあるモスクにいて、高級車でお祈りに来る人。壊れている車でお祈りに来る人。空間と逆に自分が高級車にのって行ってちょっとSmellするモスクに行く人もある。人間の心の映りが違う。で向こうに行くとオーナーさんとか、大家さんとかそういう存在がないの。サウジアラビアかどこでも。でもこ

こはモスクに入ること代表、課長、部長、イマーム、副イマーム、団体。もうみんなインドネシア人だったらアフリカ人が入ると違和感がある。スマイルでウェルカムかもしれない。大阪モスクに行くと自分が北海道だとまた。自分がそっちにどう見られているかという。日本のモスクに行くと自分のお家に入った気がする。向こうだとAllahのお家。(みんなだれでも)あと人によっても。例えば僕みたいなモスクを仕事にしてやってきた人はあの気になる。あのモスクに入るとどう見られているか、あるいは自分はどう見たいか、どう感じたいか。でも商人がスマホでここはどこMagribお祈りしたい。あ、ここにモスクがある。お祈りしてまたすぐ。で例えばこの近くにいる人がここでお祈り毎日しようと思っても、この人とかんがえが合わない場合、彼は同じエジプト人でもここではエジプトの旧政権を応援してる人とここに来る人はエジプトの新政権を応援するひとが来て、意見がぶつかり合って喧嘩になる。こんなモスクやだとか。行くもんかとか。まあいろいろ。でももちろん日本という異国でモスクを見ることだけでも嬉しい、本当の気持ち。

Q:日本のモスクで普段自分の国でやれてないことってありますか？

K:例えばトルコのモスクではお祈りが終わったら。サウジアラビアとは違う。そういうMahzabの違い。SyiahだけじゃないHanbaliとかSyafiiとか色々。

Kamata Masjid

Mr.Sharif(Bangladeshi, Have been in Japan for 35 years, He owns his own company in Tokyo)

S: 4 - 5年くらい前に建てられた。

S:最初はMushallaだった。あそこのマンション借りて。山一マンションっていうのが五丁目(蒲田)にあったんですよ。そこ賃貸で借りてMushallaとして。10人も入らないギリギリの小っちゃい所でね。結構長い、10年ぐらい続いてたかな。10年くらい続いてたんですけど、賃貸だから人が増えると大騒ぎ音とか色々問題があるから、それでどんどん人が増える事になってみんな決めてじゃあ、場所探して買いませんか。ということで、4年まあちょっと過ぎてるけど、五年未満かな、これを買ったわけですね。

Q:最初にそこにMushallaを作る切っ掛けというのは?

S:やっぱりここにイスラムの人がここにいるから皆モスクに行くの遠いしね。そうそう私もその時から最初にいました。あまり、NamazのときはHiroo行ったり、あっち行ったり、こっち行ったり遠いでしょ。横浜(モスク)行ったり時間がないんでここから。毎回も行けないから。近所があったら。もっともって探して見つけたのがここです。

Q:ここを見つけたのは?

S:不動産さんでねあっちこっち行って歩き回って。人に聞きながら売り出してたからそれで。買うことになった。

S:一般住宅だった。ここはクリーニングの工場だった。洗濯の工場だった。上、二階と三階は二世帯(住宅)だったけど。全部壊して一つの部屋にした。大工事1000万ぐらいかかった。でこれも部屋だった、トイレだったり、全部壊して。ここだけ残した。リフォームしたわけね。で形が変わったんですね。ここはクリーニング屋さん。玄関まであったんですね。カウンターで人が来たりとか。裏で洗濯物の機械で。前はカウンター店みたいな所だったね。2階か3階が人住んでたわけね。それをちょっと解除してここ作ったのね。

S:デザインというかモスクっていうのはバラバラ小っちゃいのね。部屋だとまずいでしょ。だから全部(壁)取っちゃったほうがまあこれデザインっていうか簡単にレイアウト変えて皆で決めてやったんだけど。でっかい部屋じゃないと行けないじゃない。女性トイレを作らないと行けないとか色々あってね。工事も。もちろん大工さんとかね。建築屋さんとか。大体1000万ぐらいかかったかな。(お金は)みんなからコレクション、ムスリムからね。それイスラムの人からかき集めたお金でね。使ったというか。

S:上はもっと長いんですね。

S:そ、部屋が二つか三つあって、台所あってお風呂あって色々。要は人の家だったんですね。この広さで部屋が二つか三つ取れるでしょ。台所があってお風呂があってね。全部取ったんですよ。真ん中壊して、これ4面だけ壁のこして。

人が住んでたね。そうそう人住む家だった。家わかりますよね。マンションみたいな感じ。それを4面壁だけ残して、真ん中全部壊して。間仕切りとかもPartition全部壊して一つの部屋にした。三階のキッチン新しく作った。あと先生の部屋一個作った。Imamの部屋。(上4階は)倉庫です。物置。というか。

Q:モスクのキャパシティー?

S: 今は大体100人ぐらいは2階で。ここは(女性礼拝所) 50-60人でしょ。200人ぐらい行けるんじゃない?200以上ですね。全部。1階、2階、3階。大体ね、目安として。

Jumaah,は150人ぐらいくる。200人来るときもあるし。それは分からない。日によって違う。休みとかあるともっと来る。Eidのときは600人来る。三回に分けてお祈りするからね。一機ではいきれないから。たまに(4階のスペースはお祈りに使う)ねはいきれないとき、Eidの時とか。特別のときとか。人が場所がないときは。(Jumaah?)までもつかうけどね、4階はね。そうそこ金曜日はね人が多い時、上上行くけどね。Jumaahは一回しないから。結構人が多いときは屋上まで行っちゃう。

Q:なぜ二重窓?

S:音がね。電車の音が開いてると大きい音がするから。音のないように、ある程度ね。半分くらいは抑えたかな。

Q:AdzanとKhotbahはスピーカーを使用する。

S:はい、全部スピーカーですね。まあそんなには漏れないと思うけど、ある程度大きくはしないから。漏れてもまあ住宅じゃないから。店とか色々あるから。まあみんな理解してると思う。みんなにモスクを作るということで、挨拶もしてあるから。ラマダン人が多いときはみんなちょっとね、嫌な顔をすることもあるから。たって話をするとかね。それは気を付けてるけどね。近所はねもう嫌がるでしょうね。200人も人が来たらね。イスラムの国じゃないから、場所は場所だし。

Q:行事?

S:Quranの勉強をする。この前もそうだけど。毎週、週に五日間Maghribの後からIsyaまでの時間はみんな勉強するわけね。先生が教えるわけ、Quranが読めない人が結構いる。これを大体3階でやる。ベンチテーブルがあって、先生が上から始めるからね。そこでみんなちょっとしかお金もらうけど、2000から3000円くらいかな。一か月で。そういうことやって、おしえてます。子供もくるね、大人とかね。

S:普通Eidとかは食べ物出したり、飲み物出したり。とかね。大体5-600人分。Biryaniを作るんですよ。ベント箱みたいに作る。200ぐらい、3回に分けてやるよ。3回じゃないとね。7.30とか8.30とか9.30とかね。一機に来ないから。一時間ごとにくる。そのあとは帰ってもらう。入りきれないから。200人終わったら皆帰るわけよ。8時から皆仕事あるでしょ?7時にくるわけ。そのあとすぐに解散。(食事Feast)は毎回毎回、200人一回一回で終わり。帰る時渡すわけ。(弁当を)

(弁当はだれが作る?)たまにレストランで最近レストランで注文して作ってもらう。パック詰め箱詰めとか全部やってもらって。前ここでやってたけど面倒くさいからね。みんなやりたがらないから。だからどっかで注文してもらうとか。

Q:ラマダンの時普段やってない行事はあるか?

S: Iftarは準備するですね。ボランティアみんななってね。作ったりとか。(Iftarは)毎日。大体Iftarは1か月100万以上ぐらいはかかるでしょ。ひとがまあ毎日60-80人ぐらい。くる。大体レストランで頼む、果物とか買って、揚げ物とかね。そういうのレストランで頼んで。送ってもらう。デリバリーでね。ここでは暇の人がいないから。やるのは、皆仕事してるでしょ。暇人は日本ではあまりいないからね。みんな仕事してお祈りする時間来てね。だれもここでお給料もらってないから。みんなボランティア。私も仕事しながら。できることを。モスクだからそれがAllahへの

ね、義務だからムスリムのね。よからぬことしてるんじゃないから。

S:先生がね泊まるからね。食べ物を置くとか。なんかラマダンの時色々物をね置かなくちゃ行けないので冷蔵庫は絶対必要だよ。冷蔵庫ないと人を、Jamaahとか来るとね、Tablighが来るときは、冷蔵庫使うわけよ。

S:Tablighが来るときはね。それは急に来るんでね。来る前に連絡が来て。しょっちゅうマレーシアからくる。Tablighって大体決まってるじゃないですか。若い人も来るし、年上も来るし。色々な方々が。海外からもね。(人数)は一回多いときは7-8人ぐらいですかね。(少ないときは)5-6人ぐらいとか。寝るのは3階でしょ。2階はお祈りだから。3階で普段はね。今Isyaのときに20人もいないから。その時は2階で寝泊りだと汚れるから。3階はそのとき寝たりするんですよ。

S:(1週間の行事は5回のお祈りがあって、MaghribのあとにQuranの勉強がある。)あとIsyaのあとにHadistの。Namazが終わったら10分間ぐらいHadistをみんなに説明するとか毎日何個ずつ。これはみんなお祈りして帰るだけじゃなくて頭になんか入らないといけない。

Q:モスクを管理してるひとたち。

S:この近所まあ蒲田に住んでる方が多いんですけどね。

S:(ウェブサイトでの方々の名前ありますけど、彼らに何かの役割がありますか?)まあモスクが個人名義になってるから。みんなの名前で登録されてるから。フリーのものじゃないからね。だから個人の名前が乗っかってるわけね。登録は法人登録だけどメンバーがないといけなくてしょ?Registrationするから。宗教法人はまだまだ。簡単じゃない日本は。何年もかかる。大変。宗教法人でイスラムの国じゃないから。宗教法人になれば税金ただになるから。政府はこんな簡単では認めない。何年もかかる。4-5年くらいかかる。(今は)社団法人だからね。宗教法人にまだ申し込んでもいない。申し込むもこんな(いっぱい)紙がいるわけ。履歴書出さないといけない。専門の人が頼まないと何百万もかかるから。1枚2枚だけじゃない。こんな履歴書を書かないといけない。毎日どうなってる、ああなってる。すごいこと書かなくちゃ行けない。どうして必要か税金をただにすることは普通のことじゃない。ここ40万近く税金かかれば30何万かな。それを全部ゼロですよ。国が損するでしょ?こんな簡単では許可しない。よっぽど納得いかないとね。ここイスラムの国じゃないから。マレーシアやほかのくにだと。もう当たり前ですよ。仏教の国OKだすまでなかなか。かなり何年もかかるから。一回税金ただだと、永遠にただだからね。それはおおきな金額で国は損するけどモスクは助かるわけ。

Q:Imamは何人ぐらいいる?

S:Imamは一人だね。二人とかだと給料払えないから。(ボランティアではない?)とんでもない、生活してる。Banglaから来て、食べなくちゃいけないでしょ。5回お祈り(のリード)すると働けないでしょ?DzukurをすともうAsharがすぐ近いから。会社が行ったり来たり出来ないから。Imamは5回もお祈りしなくちゃいけないからね。かれの仕事はこのモスクだね。金のモスク(?)普通のモスクと一緒に。今家族きてるから(部屋をよそで)借りて住んでるべつで。奥さんがいないときは3階で寝たからね。まあ正社員というかな。(モスクからお給料をもらってる?)もちろんもちろん。給料払わないとね、生活していけない。

S:(Imamの仕事)アラビア語教えたりQuranを教えたりとか。Imamのやることそれ個人的になにも...(一人だと)間違えちゃうからね。Imamに任すしかない。Imamの教え全然ちがうからね。

まあこれは大体わかりますよねImamの仕事はね。(KhotbahもImam?)そうそうMuftiだからなんでもわかるからね。ふつうの町のひと(一般人)じゃないからね。ちゃんと卒業したImamだからね。Mufti。ちゃんとそういう人じゃないと。間違いしゃべっちゃうと行けないからね。

Q:モスクのこれからの方針?

S:これから拡大出来ればとなりとか買って、ちゃんと立て直してモスクという形にしないと行けないというのは大掛かりの学校みたいだね。場所が問題でお金も問題。お金があれば場所もあれば早いしね。

S:(拡大の時なにを加えたいか)まあ、Madrasahというかね。泊まってアラビア語勉強する、Quran Hafidzするとかね。そうそういうことをね。

Q:(Bangladeshにあったモスクの存在と日本にあるモスクの存在の違い?)

S:モスクは大体一緒ですよ。どうやって運営するかの問題だよ。やり方をね。Banglaはなんの心配もないでしょ。

ここは(お金)はBoxに入るからドキドキするでしょ。今月あるかないか。保証がない。そういう所がちょっとテンションあるかな。

S:(Banglaモスクでやれて、日本モスクでやれてないこと?)まあAdzanができない。大きなマイクでね。それだけと後近所があまり良い顔しないというか。そういったことかな。場所がないときそとでもね。Banglaだと道路の上でもやるけど、ここでは出来ないフリーじゃないから。イスラム国だったらみんなが応援してくれるでしょ。場所が足りないときは、駐車所でも道路でも。日本ではそれができない。ルールが決まっているから。ルールに従ってやらないと行けない。宗教だから優先するなんて言ってない。皆平等だから。それは自分で住んでも分かると思う。そこが違う、マレーシアとか。イスラムの国はもう古いからここイスラム国じゃないから色々な宗教があるから。国は宗教絡んでないから。だから皆平等迷惑かけない。人近所にね。それぞれルールが決まってる。従うしかない。

(第二部)

Q:男性の礼拝所にカーテンのレールがある。それは?

S:ないよ。オープン。Namazにならない。

Q:ここに来る人たちはどういった方々なのか?

S:社会人が多い。学生はあまり少ない。金曜日に色々な人が来る。普段は近くに住んでる人だけです。国籍は?Bangladeshもいる、インドもいる、パキスタンもいる。アフリカもいる。マレーシアもいるインドネシアもいる。今日来てる人マレーシアとインドネシアがいる。色々な方が来る。アラブの方が来る。トルコの方も来る。日によって違うね。

S:イスラムはどこでも一緒でしょ。でもAdzanは向こうにあってこっちにはない。向こうはAdzan外に出せるからね。ここはあまり警察がね。近所迷惑になるからね。Imamがないから。Imamがない人は大体わかりますよね。そこの違いですかね。日本が80%-90%イスラムになつてらね。もっと自由があるけどね。

我々がまじめな生活を見せて、人の気持ちが変わってどうぞ来てくださってね。それをこれ

からみんなの色々なみんなのDutyだと思うけどね。

(第三部)

ラマダンのときIttiqafの場所で1か月カーテンでかこう。オープンじゃない。

結婚式はやる。Imamがやってる。登録するだけ。予約して。Certificateもちゃんとあげる。

人が亡くなったときはDoaする。全部やってくるから。茨城にある霊園。入れる代服とか、車で運ぶとかの代がある。

OKACHIMACHI MOSQUE INTERVIEW 01/03/2020

Mosque Chairman : Mr.Nazeer

D: When is the building was built and who was the initiator?

N: Yes. There are also time in Japan there were no Mosque. There were no mosque in Japan. You can say before 2000, there were no mosque in Tokyo, and Tokyo Camii was build in 2002 or 3, so during that period. After 2000 there so many mosque. Otsuka, Asakusa, and all these mosque came together, after 2000. So we had Tokyo Mosque until 1978. And that is the mosque now that is Tokyo Camii. That was like the mosque in Kobe. Kobe mosque was like that. So this was demolished, in 1978. Supposed to rebuilt soon. Then the Islamic country also didn't support. And no one take care of the mosque, and during that time the muslim are very careless, most of the country they don't even pray. And you should ask your parents, even Indonesia the religion was weak and then after that, by the help of Allah, the religion became a little bit stronger, so we all plan to have mosque in Tokyo and were to planning and we collected money and they descended (they sended)? And they started the Otsuka mosque. and Asakusa Mosque. After that this is the third project. So this project, because soon after, making Otsuka M, Asakusa M, and we collected money we went all over the world and so much of money we collected, we contributed to those mosque. And when this mosque was built, and in this area, many people they have idea that we already have 2 mosque. And we all already gave money why should we again? So we could not depend on them. So by the help Allah, so I am the main man to plan this. So after that by the help of Allah. Allah gave us all the ability to find the finance and everything and we built this masjid. In 2010. So this masjid at that time we had, about 32-40 people to pray. Maximum 40 ppl to pray. for Jumaag also. We had very little muslim community. And we used to take them to Asakusa Mosque, by a van. We rent out a van, on friday we would rent out 2 or 3 vans. An we drive all this people, we collect (them) all near the police box. And we put them all in the van, and we took them to Asakusa Mosque. and after the prayers, we come back drop them and we return the van. This was our duty for about 1 or 2 years. Before Okachimachi Mosque.

Then I thought why not we have a mosque in Okachimachi? And this is the center. Then we plan this and then by the help of Allah, we found this place, and we could build this masjid in 2010. So 30 -40 ppl, was gathering at that time and the when we build the masjid and we thought only one floor is enough. Today in our masjid, all 5 floors full and the road also full and half of the road also people praying. And so you can see the photographs here and again the second Jumaah also same. We had 2 Jumaah. We have about 500 people. Every week every friday we have about 500 people they come to pray. And 500 people also cannot pray because we dont have enough space so usually people they

pray on the stairs they pray here (The lounge 1F) also in this floor also full. And outside also full and all the stairs are full and they will be a queue.

F: Many people outside, road.

N: Roadside. And not only this, because sometime when we had Eid prayers we have from that corner to other corner of the entire road, this road. So much of people coming and so now by the help of Allah, and we have bought bigger place near the station Okachimachi station, and so we are thinking of rebuilding making a mosque new Big Mosque. 2000 people, minimum 2000 ppl can pray. And this is going to be like a very beautiful mosque Insya Allah. So this is our plan. This is soon we can make it, because the Olympic is coming soon. And because of the Olympic the price construction cost is very high. and after the Olympic the price will go down. So now we are thinking to shift this masjid there. Because now we have a lot of space there. And people they dont have to pray in the road. To do some renovation. So for that I want to consult you and if you can help me for the measurement or something like that. so we can get down some architectural designs from Morrocco and we can fix it. and we can ask them to make it there. Once it is done we can get down by shipping it and we can fix it. And then see, for 2 or 3 or maximum 4 years we can have this. And we can see if this design is durable and good for this weather, everything we can see. then the future then after that we demolish and we put the big masjid. and then we can same thing or different thing we can use. If that material is not good, and if you use it and if that become crack or it become something. So it is not worth.

N: So for that I am thinking. Simple thing I want to built in this masjid. So until next year, we wont be able to start there (at new place)

D: So the palce is actually already settled?

N: Already settled. Becuase there is 1F tenatns is still there. Tenant is leaving maybe middle of this year.

D: Is it still in Tokyo?

N: Yes its near the station from the station you can see the masjid. And all the train they have to pass the masjid. and about 5 times bigger than this land. And also we are planning to buy the next door also. And if you buy the next building also then it will be about 120 tsubo. Now the property we bought is 68 tsubo. and so we are planning to buy is 52 tsubo. and if we buy that it will be 120 tsubo. This (current one) is only less than 20 tsubo. And we will put a 8 storey building in Masjid shape. So this is our new plan. So for that by the help of Allah. We are working hard and when time comes only Allah have to give us the ability, no one can do that. So we are waiting. Making dua and everything. Very soon we will start there. So this our main point about the building.

D: Before you mentioned about it was the 1F was use for the mosque? (What do you mean)

N: Because 2F for ladies, and 3F for the mosque. And now you went to see the 4F and 4F so we pray 4F, 3F, and the ladies second floor. and ladies second floor friday we use it for gents. because overcrowd. Only for Jumaah. But for the second Jumaah the ladies can come. So the 1st Jumaah the ladies can participate but the second Jumaah the ladies cant participate. Because its overcrowd. So this is what we are doing now. And today my wife said even the second Jumaah was Lady full. A lot of ladies.

D: Who is the initiator?

N: We are not a special group because we are the Muslims from different countries, from Indonesia, Malaysia, SriLanka, Pakistan, India, Arabs. So many people are here. And specially in this area they are very view people were living. So those people we cant say that they were from one particular community. So different community, all the brothers supported us. So by the help of Allah. This is the miracle this masjid it self is a miracle. Because when we got this paper this land is for sale. This paper the fudosan. When I got it to my hand. It was already closed (sold). So I got it on friday evening. For example, it was on my post, and ususally I dont see post. and that day I had to go to gasolin station to pump gasolin to my car. And I thought to get the car wash dirt. And I told my wife the house is very close by so you go home, and I forgot to take my handphone, so please bring it my phone. And she says no no i cant do that. But please. So she said okay and she went. And she came and after taking my phone, she just went to see the post because there are a lot of post, you know. Then she found this paper and once she throw and again she took it. and she show me. she brought it to me and then I saw that. And from the station straight away, we got the car wash and we came and we saw the place, we liked the place and we called. The fudosan said already we sold, everything finalized there were no point its too late. Then I didnt give up still I like this place. Can you talk to me. Can we meet and talk. Then he said if you want you can have a look, but nothing can be done because it is already sold, because you came all the way to see, then you can just see. then I said okay I can see. then I came I checked the qibla straight, and I went upstairs and I saw everything and top floor. And I call fudosan again. then he came, I said I want to buy this property, can you help me? If you can help me it will be great. then he was laughing because it is already finalized. And then I said no, please. Then he said I will ask landlord, the landlord is there, their have their own stairs, and he went and spoke to the landlord and he came said we have sold this one about almost 1.7 mill is their price the owner wanted to sell. So it was sold something less then that. So if you like to pay full, then the owner said doesnt mind they can sell it to you. then I said yes we will pay full and we pay cash now. And they said yes, and straight away he took and same moment we out an agreement. then after put an agreement, so the guy who wanted to buy, he came they said no you are offering low, so we got our price we sold it. then how much? and cash. and we said its okay and we paid cash. We will bring that money. Then the owner said I can see people, but I prefer to sell it to him. To us not for him. But they

are from the same community. They are not for our community, they are Koreans. The original owner was Korean, the person who wanted to buy is also Korean. This Korean is a friend of mine. He is doing some work for us, we do subcontract, to him some work. Some jewelry manufacturing, we do subcontract to him. So this guy is our workers. At this process come to buy they are same community. But they refused. If Indonesian wants to buy and the Sri Lankan wants to buy, will you sell it to the Indonesian no? Your Indonesian will never sell to Sri Lanka. So this people you know, it is the miracle of Allah.

N: So this is the way we got it. And it is beautiful story and then alhamdulillah by the help of Allah, following few month in Ramadhan we quickly did everything, and before Ramadhan we manage, so first of Ramadhan we had it 2009. We had Ramadhan and we did official opening 2011 I think.

D: It's a renovated right? Who decided what to put on the floors? (design?)

N: everything I decided myself. because when we consult and if I consult him and he may have a different idea because he is a... the thing is in Japan, you must have a person who has experience. Person who has lived here for long. And so when we bought Otsuka Masjid and we had the first committee meeting, I am also the founding member. Asakusa also same. then at that time when we had meeting. And we had the about 20 different community people then the people they say, I prefer to paint green colour, to entire building and another person said no, white is better, and another person says no, and two colors we don't like, we have to go for blue, common colour, so no green no no, all fighting, everything nothing you can't come to any conclusion, then when there is no conclusion and always you get the still same, and where there is a lot of people especially Muslims. You are Muslim so you know, if you are not Muslim I don't tell this. Muslims they always don't come to conclusion. they will always have an opinion, you know they say no this one is that, that is better.... but they don't think about the future and longrun. Not that my word is important because I am great not that. So longrun, what is suitable for this. That is the important point. So for that I had the committee I made the committee, and in this committee I asked them how shall we do this. And that committee said you are the most senior, and we all knew. We know very little about Japan. So you are the most senior, you have experience, you know what is the best. Your decision is our decision. So everything black. So alhamdulillah. from zero, till last everything by myself I decide. So that was very lucky. even the new masjid also we do the same. and we don't consult all the brothers. so we will just inform them and update, now we are doing like this, report. So they will be happy.

D: When the building is renovated, what kind of did you use the local Japanese contractor?

N: First, we went through a lot of difficulties, because we, there was a Muslim contractor, local Japanese and working members are Muslims. all Muslims, the Japanese also Muslim

Japanese. and he has done so many mosque, and this and that time so many people introduce me, and I got down here. ...(D) Yes, a muslim japanese contractor and muslim people were working for them, and from Indonesia, and from India, well these countries. And they are all muslim group, but look like a jamaat group, all bread and so not very neat, no qualification nothing. But first I gave it to them, but a every week they take a lot of money from us, they pay this much, this much, but everything, nothing happen. all just we got cheated, and everything is half, this half, this half. So ultimately we stopped them, and we call the Japanese contractor, and what company, we asked them to give the estimate and we find less an we gave to them. so everything went well. So here after we will not give to muslim contractor.

D: What kind of facility does this mosque have?

N: As the mosque, whatever our duty, so all does things are done here. for example, da'wah. So here (1F) we do da'wah main. and again we do, when you came here I was giving da'wah to one japanese. So like that we give appointment, we give time and so that particular time we come and we give them da'wah. And then again we teach them Quran. And the people they want to personally, they want to learn Quran, so we make an appointment with the Imam, and they come and learn. And they are groups children, and they are classes, and decide the time, and those time for a week 5 days there are classes. So those children they come and learn Quran. And again we have a Halal training. so we have Halal screen. and we gave them Halal training. and Halal lectures. and these are also done here.

D: what is Halal training?

N: Halal training means if someone wants to become halal. This restaurants wants to become Halal. Then we give them training. How to make halal, how to make halal food. What things that you have to avoid, what is free, and this food should not be used. this can be used. and so all those things and hygenical system. and so we give them lectures. that base on Halal. and so lectures that promoting Halal. And people that do shahadah. so they can make shahadah, and then we give them training of prayers. And sometime those people they like to marry, so marriage also we do here. And again we also have all type, of prayers, to Eid prayers, Jumaah prayers and during Ramadhan we have 20 days breakfasting facilities (iftar). Iftar we provide for a day 300 people, and they breakfast and we give them dinner, also. So this is continuously 30 days we do that. And also taraweeh prayers, and again we have Qiyamul lail. Last days we have Qiyamul lail. So we gave down scholars from different countries, so those scholars they come and we put notice and we inform people and they will give lectures and so those things also we do. And the funeral facilities that also we do. and so what ever the facilities and whatever activities mosque should do, by the help of Allah everything we are doing. and maybe few things I forgot, If you mention everything is there everything complete. Nothing is left.

D: can you describe me the weekly schedule?

N: weekly schedule means that we started from Friday at the Jumaah. and that Friday other than Jumaah, we keep Friday free for the Imam, to keep Friday free (off work?) because Friday he has to conduct Jumaah, and so practicing and he has to spend a lot of time. So that day will be free but Saturday we have lectures every Saturday we have lectures. so the Imam give speech, and the local community and Japanese new muslim or People interested in Islam, All those people we gather. and we give speech in English and we give translation in Japanese. and after the lecture we serve them dinner.

D: what time is the lecture?

N: It's 19 o'clock, only next week, tomorrow Saturday we don't have lecture, because the Imam has gone, and he is coming back so temporarily only one week we don't have so after that we started 7 o'clock. everyday every week 7 o'clock. Then Sunday usually we open for Halal, and we will get inquiries for Halal so there will be a lot of visitors. a lot of tourists they are coming from Indonesia, Malaysia to pray. and so they like to go to Halal restaurant. They ask where to go how to eat and that all those things we teach them. A lot of visitors also coming and asking information about Tokyo and Japan. All those information also we provide. So there will be a person all the time here. So someday as usual the children they come, Friday, Saturday, are holiday. Children also. And Saturday also children class are there. teaching Quran are there. And almost it is depend on the inquiries the da'wah, da'wah non stop inquiries are there round the clock we do the da'wah. Saturday also anytime. This guy (previous guy that came) came during Jumaah and he says he wants to know about Islam. After Jumaah I talk to him. even had lunch and he called me. and I came and I gave. so this is what we do. So this is non stop. anytime. and there are brothers from far. They can't come because they are from Hokkaido. from very far areas. Even from Indonesia they call sometime. Japanese they live in Indonesia. so Malaysia. So different parts of the world. So this people I give them da'wah by phone, whatsapp. we used whatsapp or line. and so this also we do it. so It is depends on the time schedule because my schedule their schedule we fix it. and then we will give them and the imam is there to teach them Quran, and if anyone wants to learn Quran, so this is his duty to Quran, taking care of the Quran and conducting 5 times prayers and Jumah and giving lectures. and these things Imam. Especially Da'wah matters I do myself. and so when we have scholars from abroad, so the scholars sometime we use them for the da'wah. So while we are giving da'wah so when they want give shahadah, new scholar arrived we give them shahadah through the scholar. so like that also we do. Again also Monday same rotation and if some scholars visits us and some special lectures and some workshop like how to pray. We will have a workshop, something about Halal you do a workshop, and how to train people. Once in a while we do that also. So there are lot of activities but it depends on the time. The people coming on Saturday most of it are from out of Japan. because of the holiday they are coming back Sunday. So that why we canceled the program because if the people are here and it's okay. If they are not here, we

have to make meal in its going for waste. so we had Quran competition also before. The children after learning the Quran, recently we decided every month to have quran competition. And there are children now increasing number of children and so those children to encourage them so we bring them chocolate cos in the end of the year last year, I wanted to have a Quran competition so I brought a lot of chocolate, and some from Indonesia, from malaysia halal. So those things, I can't keep it for long because i thought to distribute yesterday i call all the children to the new masjid. and they gathered and i give them everything and i finished. actually i wanted to use it for the Quran competition but. So like that we have plans, but this is adjustable. not particular day, if some children they are not available they will cancel and we keep the day that the childrens are available.

D: how many children?

N: According to Imam, number of children increase about 30 children.

D: How building is used for the program?

N: Because building in the 4th floor. We use when we have anything special program conducted on the 4th floor, the one with mihrab, so that is the main floor. There we conduct and we have screen in all the floors and people overcrowded 3rd floor also that they can see. and the ladies floor they can see from the ladies screen. So that is the facilities right now we are using. So when we finished the program, so we will have the dinner or lunch in the 3rd floor for gents and ladies at the same place (2F). Lunch will be 3rd floor and ladies will be the same. because we dont have space.

D: how do you get the food?

N: We have a permanent cook here. So we prepare our dinner, or lunch. For particular event we make everything ourself.

D: For children class where?

N: They use this here (1F), or they go to 4F. and less number of children and the classes divided sometime and then they use here. We can put all the chairs and then 20 children can easily sit. Otherwise if we are busy doing da'wah or soemtime more children they go upper floor.

D: Capacity of building?

N: Everyday prayers average about 50 people come, because in indonesia in malaysia muslim countires there are a lot of people, retired people old people. and they are at home. so once everyday every 5 time prayer, they go to the mosque, and here you can't see that. Only youngsters. and these youngsters they come for fajr sometimes, sometimes they dont come, they come only for Isha sometime they dont come even for a week, or sometime month. 2 or 3 month we dont see them. and they stop coming. So this is the system in japan. because these guys they are young. and so they are not 100% occupied, with the masjid. But Jumaah and ramadhan so they put pressure and you can all see them. and so until ramadhan, you can see the masjid is full. and eid day, fajr prayer, ony Imam myself nad three of us. This is the muslim community, because they are close to

shayton, they are very much attached to shayton. so during the time of the ramadhan, Allah keeps shayton chained, and shayton cannot disturb so the people are free. So they come. and then eid day all open. so today the last day of ramadhan and once it is declined all the satan gone out and they are back to their normal life. Not only here but i think all over the world. So anyway Allah give them hidayah.

D: For the Jumaah, how many people come?

N: For jumaah 500 ppl come. For eid we have 5 times shift. we officialy say 2 or 3 but unofficially we do (5). sometime 6.30 masjid is full. Usually we say 7.30, and 6.00 masjid is full. and 6.30 we will have a one prayer. and second prayer we will have at the same time (7.30) and then after that like that we see the crowd according to that we will manage.

About over 1000 people. 300 people we have one circle.

D: When overload which space are used?

43:00

D: who manage the mosque?

N: The Imam we bring from different countries, so we had Imam from Egypt, we had Imam from sri lanka. We had Imam from Indonesia, malaysia. so it depends so next Imam is coming from Malaysia. Usually one Imam can manage everything. because this is a small masjid. And we have limited space. so if we have more space we can have more Imam, Becuase our classes also, we have the Quran classes fixed, The imam duty only limited becuase they have to do 5 times prayers and Jumaah. And only during ramadhan we get down 2 or 3 Imam. and only ramadhan we will also have additional cook. other then that only 1 imam would do for us.

N: When the Imam is not available, we also have people surrounding us, and i also conduct prayers. And whom ever they good in prayers can recite Quran and they are capable of doing those people they do and no need me to be here all the time. and if I am there that would also do. And today some tabligh jamaat has come, so they are conducting the prayers, otherwise I could have done it.

D: Who teach Quran?

N:Iman

D: what is the 5th floor?

N: Staff quarters. So the Imam room is there and the cook the person who is taking care of the masjid, the cleaning and the washing and making meal so his room is there. Imam and cook lives in Masjid.

D: What do you do after praying on Eid?

N: After prayers we have a get together and lunch also, we made special lunch, sometime we have surrounding. Before they used to bring each and every one, they bring some sweets. So they bring their own sweet and they bring some gifts to the kids and they exchange this and that, and then we give ice cream last time. Ice cream we distributed to all

the people and we give the ice cream can that turkish ice cream. So they also come and they do perform, and everyone they can eat as much as they want.

D: Is the always cooked by yourself?

N: Yes, because on 6F we have another kitchen that kitchen we use for cooking for ramadhan. Daily we buy fruits, first we serve fruits, and after that we serve dinner. and so all those things we made here. and sometime, some restaurants they want to serve us, they want to give us a gift. so sometime they give us and we take that. But 99% we cook ourself.

D: Tabligh?

N: This tabligh we dont encourage them in this masjid because of our limited space, and when they come and occupy here, and so we need more rooms, to sleep and then they sleep in the mat, and then so we dont encourage, so they stay somewhere here, maybe their friends house, and they can come for the prayers, and they can gather they can discuss those things we allow them. many thing they can discuss connected to Islam. Only thing we dont give them is to stay here, because if they stay here they have to cooking also we have to give, and if we give that also then they will make it dirty. And so that is the only thing so we dont do that. Other then that all other facilites are there.

D: Mihrab and ornaments how you make it?

N: Some we got down from abroad, but at that time, we are in hurry and little time, so we wanted to do in a rush. and so what ever available we get it. so i went to turkey so i bought this, and this was made it for some other client so please give me this. then he said no, this is someone else. I pay you and I pay you more, then he said okay. So this i got it. When we are in hurry we dont bother, so we take things, in what ever so we did this to the masjid. For next masjid we want to take more time to do it. more deocration.

D: who made the mihrab?

N: This one very difficult to tell becuase at that time we had the people so those people we asked them, so they brought some people and then they discussed. and now those people they are no more here and some people are here. We brought it from outside (out fo japan). The dome we made it here, it was difficult we made 3 times and everytime failed the shape was not good. and japanese they did, and too much heavy. and finally they ask the people that make the disney that material very costly was about 15 mill, or something like that. They made with some fiber(glass?) cos cannot let too much weight on top of the building, So the weight need to be less and durable, and the only thing the color has gone, becuase we used it 10 years. If we paint it, it was beautiful like turkish and beautiful color. shining color, and now the colour has gone, cos we are going to change the mosque so dont want to concetrare on this thing, otherwise if we do that, once again is going to be very beautiful. and whatever available in Japan and the japanese technology.

Arab Institution

Satou san

S: 90年代はこの建物を使って、アラビア語をやっていたので、その時点では大使館はすでに六本木に移っていた。移ってからこの建物まあ二階建てくらいの小さな、そんなに大きな建物じゃなかったらしいんですが、その建物をイマーム大学の分校として使わせてもらっていた、でそのときもちろん礼拝所もありました。でその建物を今度はまあ大きくリニューアルしようという話をまあ90年代後半から出ていて、実際にそれがサウジアラビアの外務省それからイマーム大学というのはもちろん大学なので、まあ国立の大学なのでサウジアラビアの教育省の管轄なんですけれどそれから日本側の許可もちろんいまして、ま学校を建てると、許可も新たにとりまして、そういったアラビア学校をその中には礼拝施設もあると、モスクの機能も備えてあるという了解を日本政府からもらってオッケというもあって、でしかもここは外務省の持ち物であったわけなんです。大使館なんです。外務省の持ち物をイマーム大学は教育省ですよ、教育省に移転するということはものすごく難しいことだったんですけど、それが上手くいまして、そのイマーム大学(教育省管轄)の分校として新たにここにリニューアルオープンしたのが2000でした。ちょっと複雑あんですよ。

でそれから今に至るとい感じ。建物は全部立て直しです。もともとは古くて小さい建物だったのでそれを全部潰してもう完全にリニューアル建物をそのままりフォームしたというわけではないですね。もう全部0から建物自体地下2階上は4階建て全部で6階建ての建物です。で礼拝場はその中の一階の一番大きなスペースは男性の礼拝所になっております。男性のMusallaで2階は女性のMusalla。二階自体は女性の階なので女性用のMusallaがあります。で金曜日のEidの日なんかはそれだけでは足りない。例えばこの三階のこのスペースも開放したりとか、あとB1に多目的ホールというのがあるんですよ。そのスペースを使ったり。あとEidの日とかは解放してそこにも礼拝、男性ですけどね、男性をいれます。で金曜日のときは男性の一階の

S: B1に多目的ホールというのがあるんですよ。そのB1のスペースを金曜日、それからEidの日はやっぱり開放してそこにも男性を入れます(礼拝)。金曜日はそのB1のスペースとあとは男性の一階のスペースがほぼいっぱいになります。

D: じゃ女性は本当に二階だけってこと

S: 基本2階だけです。Eidのときはそれでも足りない。2階に行かれましたね? 礼拝スペースはまこちらがわになっているのですが、その前にちょっと広いスペースがあったりしますよね。その広いスペースもやっぱり開放しないとどうしても間に合わないですね。

D: 3階と4階は普段女性は行かれますか。

S: 4階は学院長室とかそういう場所なのでまあ普通の人は入ってこないです。職員とかですね。3階はまあこのスペースは教室と学生課。教室は3つですね。そこそこここ、学生課とあと教務課。で教室のうちの一つがコンピューターが備えてあるコンピューター室になります。

D: モスクでの行事なんですけれども、学校の行事のExtentionとしてなにかモスクのスペースをつかったりすることってありますか?

S: あります。会議とかシンポジウムとか、セミナーとか内外、まあ外部からも人を呼んだりして、

なんかイベントを開くときに、一階の一番広いスペースを使います。礼拝所ですね。

D: 年に必ずやる行事とかってありますか？

S: 礼拝場のスペースを使ってですか？必ずやるのはもちろん礼拝以外ですよ？Jumaahの礼拝とか、Eidの礼拝とか別にですか？例えば文化関連の卒業式ですね。

D: 卒業式というのは、まあ一番広いスペースなのでそこが一番いいですよ。あとは12月になると国連のアラビア語デーというのがあるんですけど、まあアラビア語というのはその国連の公用語の六つの言葉の一つでそれをお祝いしようというのが世界中でとくにアラビア諸国の国なんかがそういうイベントでアラビア語デーというのをやっぱりそのシンポジウムの形にしたりとかなんかアラブ文化の紹介とか出し物とかするので、どうしてもやっぱり広いスペースが必要になって、それも毎年だいたいやってますね。あとはまあ、毎年なんかシンポジウムとかそういったこともやってます。文化とか経済とか、アラビア語、アラブ文化関係そんな感じの大きな会議とかで一階の礼拝室を使ったりします。

あ、あとはですね。Hajjのシーズンが近づくとHajjの説明会というのも今年はやらなかったんですが、その前までは5年連続でやってましたね。それは日本語と英語とインドネシア語で。インドネシア人で日本からHajjに行く人はすごく多い。今あの日本ではHajjのAgentがですね。3つか4つくらい会社があるんですけど、それに参加する日本からHajjをする人たちのですね。たぶん半分以上はインドネシア人なんです。なぜかというインドネシアでは中々できないと、Waiting listがすごく長いので、で日本ではとりあえずお金さえ出せばまあいけるということで留学生とか研修生あとは会社員とかそういったインドネシア人の人たちが日本から行くというのをすごく多いです。Hajjの説明会も毎年やってます。宗教関係はもちろんEidの礼拝はもちろんやってます。

あとは外部から誰か訪問者が来たらまあイスラムのことを知りたいとかアラブ文化に興味があるという人が来ればその礼拝所を案内してみたりとか、そういうのもやります。

D: あと例えば結婚式とか

S: あ、そういうのはやってないですね。結婚式というのはやってないです。あのムスリムになりたいという人がいたらそのお手伝いとかまあちょっと集まってSyahadahを見届けるっていうのはやりますけど、とくに礼拝所ではやらないです。まあべつのゲストルームとかを使ってSyahadahをやります。

D: Jumaahの時なんですけど、Khotbahだけですかお祈りの後は。その流れの中にあるのは？

S: Khotbahはアラビア語なんですけど、その前にKhotbahの内容が日本語と英語とUrdu語。パキスタン系の人インド人とか多いのでその三つの言葉でまず簡単に翻訳を読みます。でそのあとにアラビア語のメインのKhotbahをやると。

D: JumaahをImamする人なんですけど、それは学校の中の人なんですとかそれともどこからか。

S: 職員ですね。

D: いつも同じひとですか？それとも

S: 決まっていますね。

D: その人は普段は教えてる人ですか？

S: 色々ですね。教えてる人もいればメンテナンスの仕事をしている人もいますし。とにかく職員ですね。

D:職員でも一人の人じゃなくて

S:三人います。はい、三人ローテーションで。

D:Capacityなんですけどもモスクエリア事態はどのくらい人はいますか？

S:多分全部あわせて500人ぐらいいはれますかね。B1とか一階二階それからこういったスペースも、一番キャパシティーが必要なのがEidのときですけどそういう時には500人は入ると思いますね。一番いっぱいになると。一階に入ってきたときのエントランスとかもちろんあの開放したりとかおおいときには、駐車所のところまででるときもあります。それも含めて全部であら500くらいは収容できるかなと思います。

D:Jumaahのときはどれくらい人集まりますか？

S:200-300人くらいじゃないですかね？大体ですけど。

D:モスクの中にコミュニティに関連する活動ってありますか？

S:そうですね、協力してるイベントはあるんですけどそれは別にモスクは使わないんですが、会議室、B1の会議室をつかって毎月第二日曜日はあの日本インドネシアムスリム協会という所があってそこはイスラムゼミというイベントを毎月ここでやってます。こちらとしては場所を提供してる。場所とか施設ですね。プロジェクターとか椅子とかテーブルとかまあ後で館内をご案内します。そういうの使って毎月やってますね。日本インドネシアムスリム協会。ライブをして動画発信もしてます。

でその活動というのは基本的に日本語でイスラムを説明するというで毎回いろんな人を呼んできてですね。レクチャーをしてもらうという。そういうコンセプトのイベントですね。それにこの学院は場所を貸してますと。

D:ラマダンとか普段日常でやってない行事とかってありますか？

S:いつもではないんですが例えばQuranの暗記のコンペティションとか、そういうのが時々あったりします。あと礼拝のあとにでそのイスラムの話をしたりとかそんな程度ですかね。あともちろんTaraweehとかそういう礼拝もやってます。ラマダンのときは。

D:断食明けとかそういう行事は？

S:行事はまあEidの礼拝だけですね。

D:学校自体はインターネットで16.30まで開いていて。

S:例えば夜のクラスというのもあるんですよ。夜のクラスは、例えば昼のクラスは10時から2時までで週五日月曜日から金曜日まであるんですけど、夜のクラスは月曜日週三日あるんですよ。月曜日、水曜日、金曜日。で18.30から20.30までやってますので。まあそういう人たちにとってはまあ普通にはいってくれるんですけどね。

D:全体的にモスク自体は何時まで開いてるんですか？

S:はっきり言って礼拝にきたい人がいれば入れます。ムスリムで礼拝したい人は。例えばFajrの時間でもIsyaの時間、まあ今Isyaの時間早いですけど、それ以外のときであっても礼拝したいと周衛の人に行ってもらえれば、普通入れてもらえます。普段から来てる人はわざわざ断る必要はないんですけど。ちょっとなんか外部から来てる人は多分周衛の人に断って礼拝したいんだけどみたいな感じで、基本的にはまあ礼拝したい人はいつでも入れるかなと。でもこの場所がらですね。そんな夜遅くは来ないですよ。深夜とかそんなにあまり住んでる人はいないので。

D:建物はだれが設計した？

S:わからないですね。

第二部

S: ...の責任者などを集めたMeetingとかあとラマダンの時とかIftarパーティもかねて、やってくるというのがありますね。モスクの責任者。

D:それは何かの会員に入ってる感じですか？

S:べつにそういう訳ではないですね。ただ集めてまあ、親睦を図るみたいなんです。そうですね、そんなに堅苦しくはない。

D:これっていつも下駄箱があるんですけども、これは靴なしとありの所ってなんか決められているんですか？

S:原則この中あの土足禁止です。スリッパに変えて、あでもこれはここの職員のメンテナンスとかしてる人の靴ですね。下には図書室と視聴室が一つと。

今も横浜でサウジアラビアの文化的なイベントをやりまして、そういうイベントがこういう物を持っていて。あとアラブのテントっていうのも一式あるんですよ。そういうのも入れて、テント立ててでその中にこういう物を置いてまあ、サウジの文化を先ほどのアラビックコーヒーとかとともに味わってもら、そういったことに参加したりしてます。

S:図書館はオープンなのでよかったら使ってください。これはここでの出版物。これはアラビア語のテキストをですね。これはここで行われたセミナーとかシンポジウムの記録集みたいな。アラビア語と日本語。卒業文集。まあ、今までで1982年から4000人(卒業生)ぐらいいると言われてるんですけど、まあそういう人たちが同窓会を作って色々な記事を書いたりしてるという同窓誌ですね。卒業文集はべつ。

Q:ここの学生は？

S:日本人がほとんどですね。

Q:修士とかそういう感じの

S:普通のアラビア語講生ですね。2年間の。

Q:で卒業をするためにはなにか書き物をしなきゃいけないですか？

S:そういうことはないです。テストにさえ合格すれば。卒業できる。卒業証書っていうのをもらう。それでここにあるのは学校関係者が書いたものとか、世界のMasjidとか、世界のやつですけどね。日本じゃなくて。これは日本の昔話をアラビア語に翻訳。絵も自分でかいたんですね。

D:こどもの学生とかっていたりしますか？

S:年齢が一番下は中学生だとうですかね。高校生からだったと思います。上のほうは80代の方もいらっしゃるんで。

S:こちらは食堂の職員むけのですね。こちらはコックなんですけど、イベントなどがあるとbuffetとかは彼が作ってます。モロッコ出身のコックでアラブ料理なんでも作れます。

C. Sketches of Study Case

No. 1 Tokyo Camii

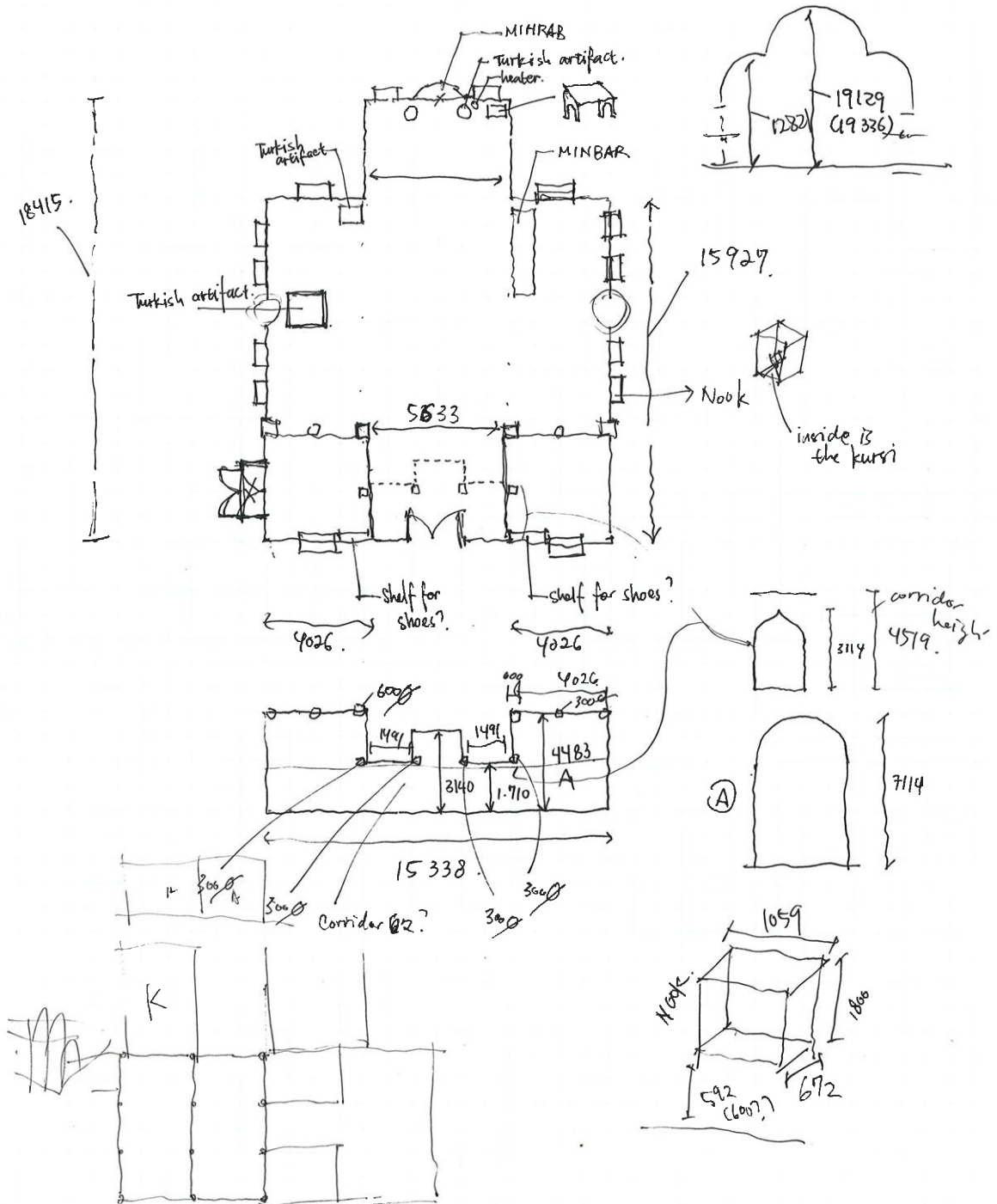

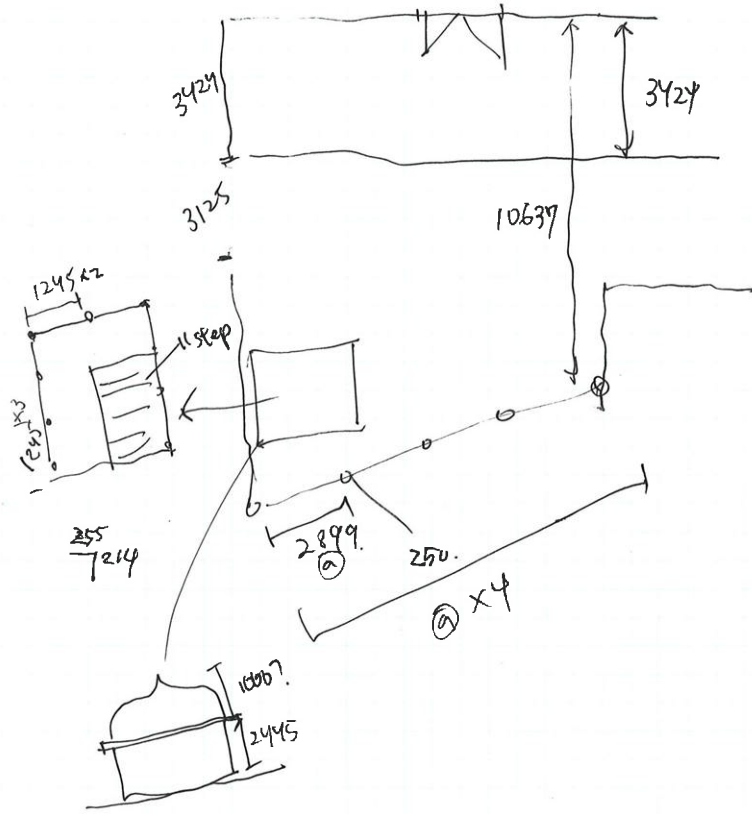

No. 2 Dar Al Arqam

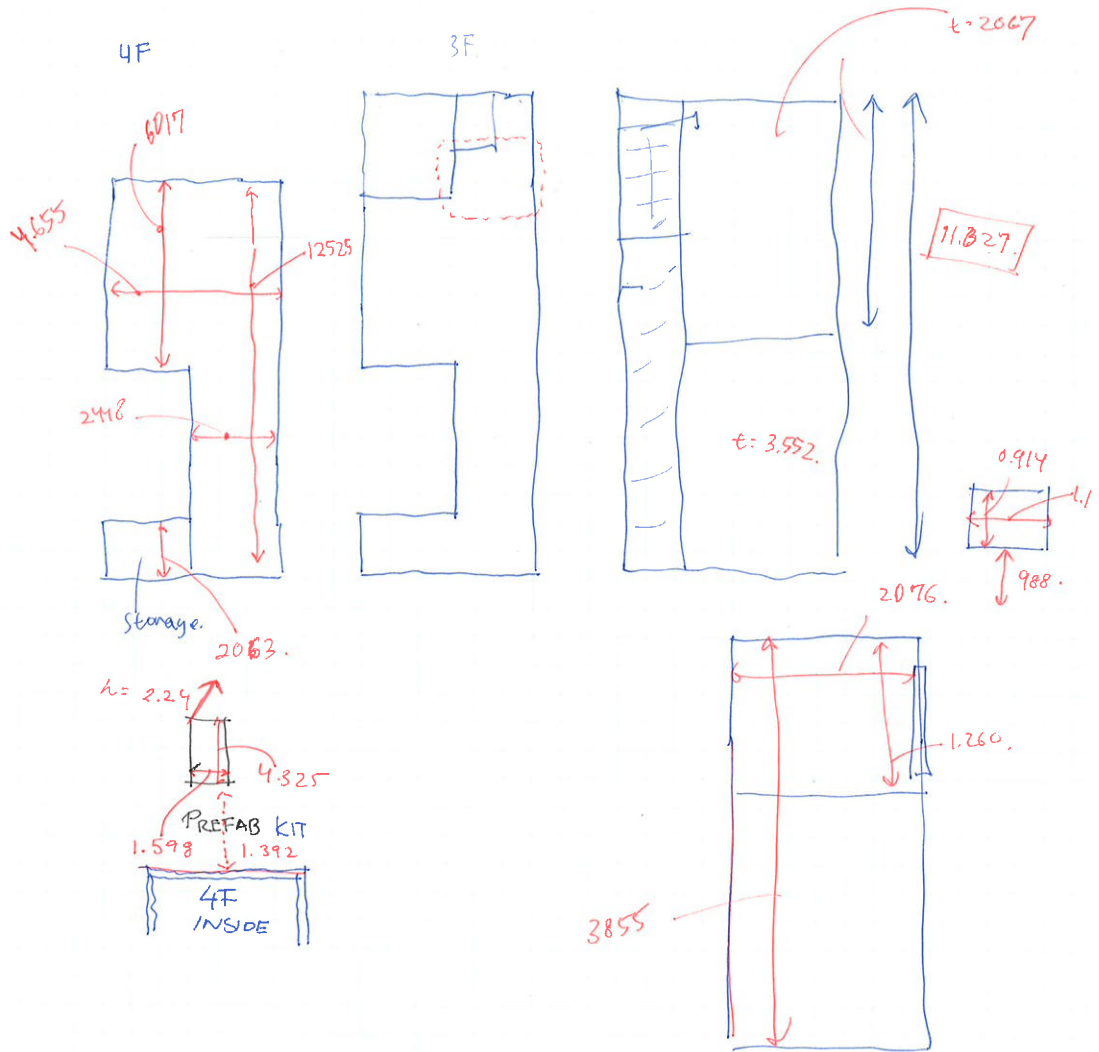

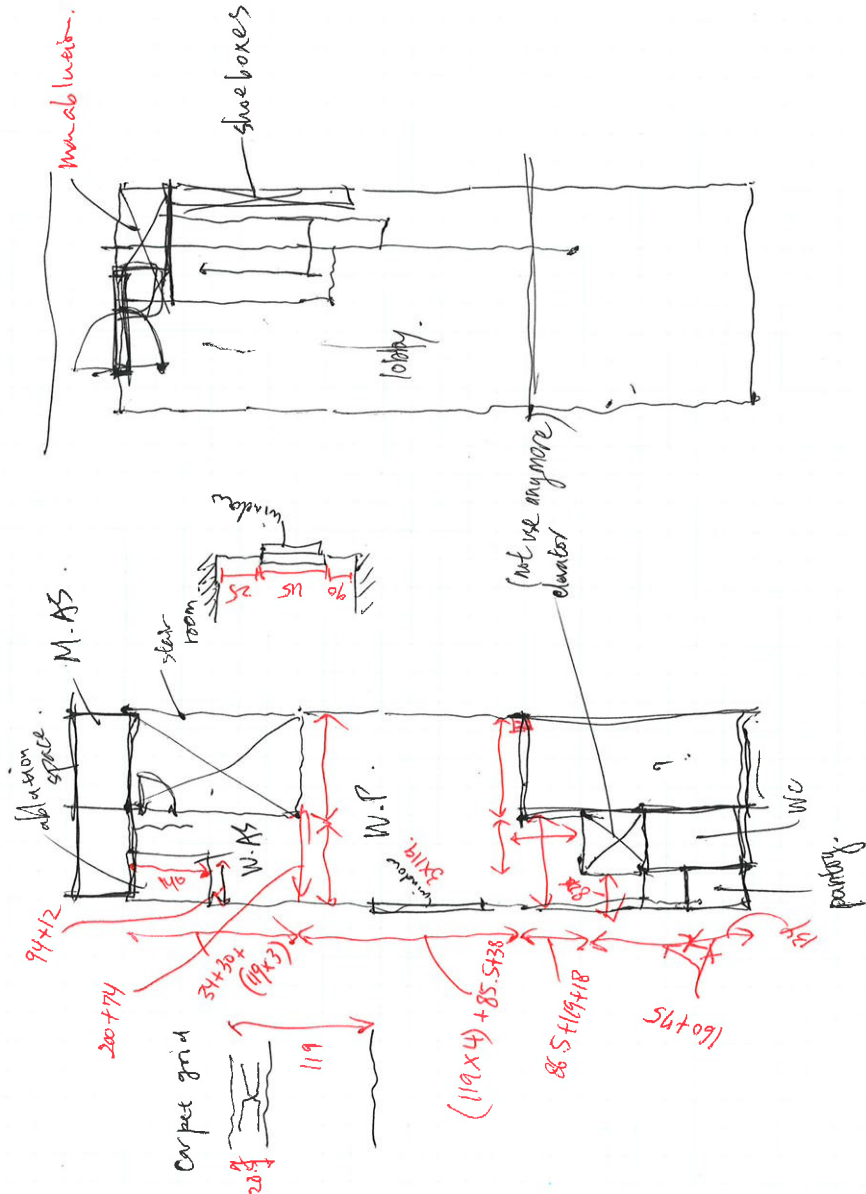
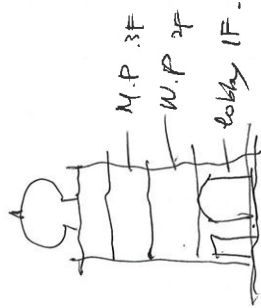

"ACARUVA MOSQUE" 1/4 18.00.00.

OTSUKA MOSQUE (IF)

- Keelankuro no Mushalla.
= lusaban kojyo.

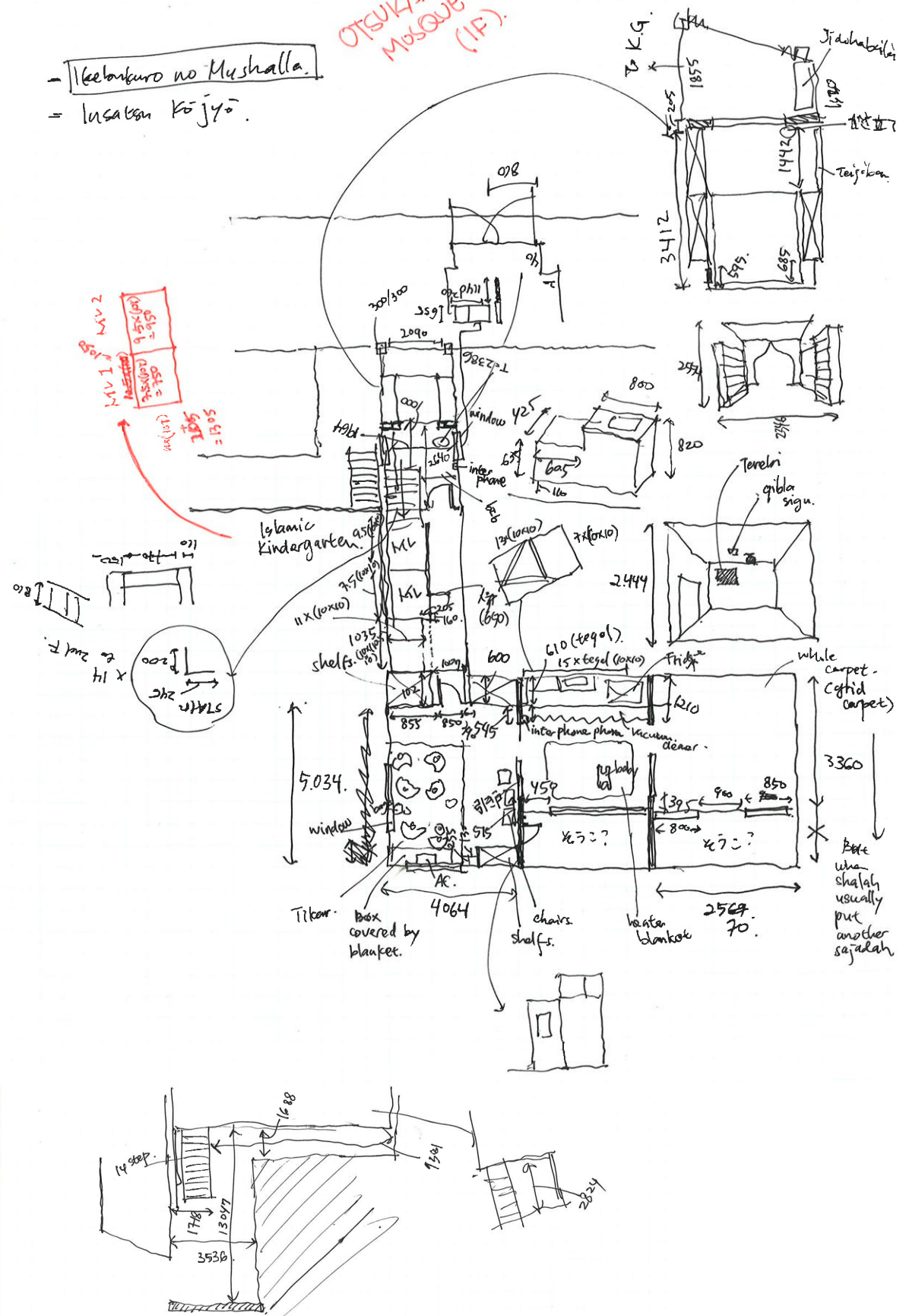

$$(134 \times 6) + 114 + 11 = 804 + 114 + 11 = 929$$

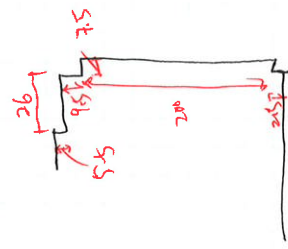
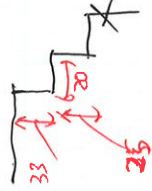
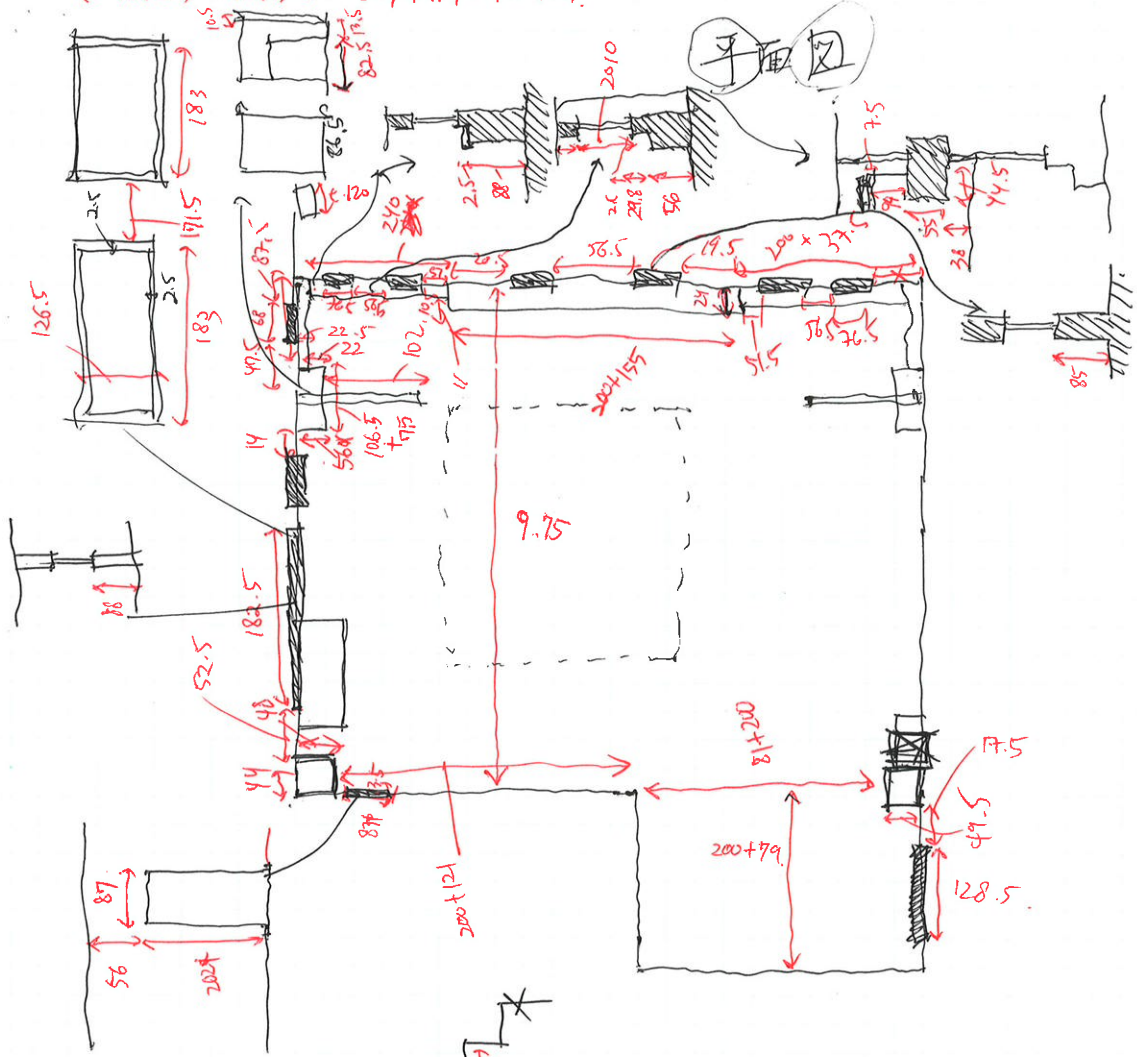

M.P. (IF)

11/15

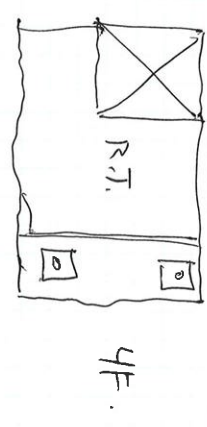
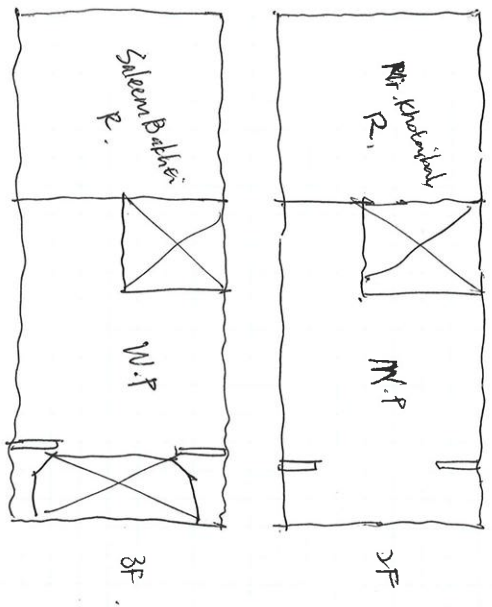
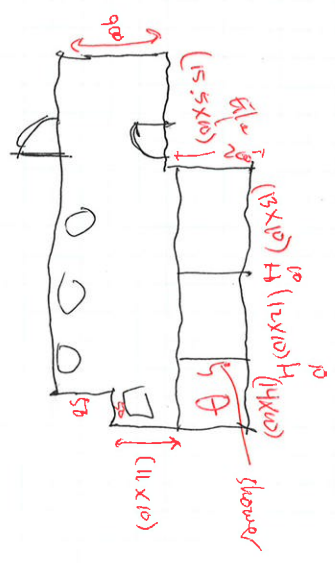
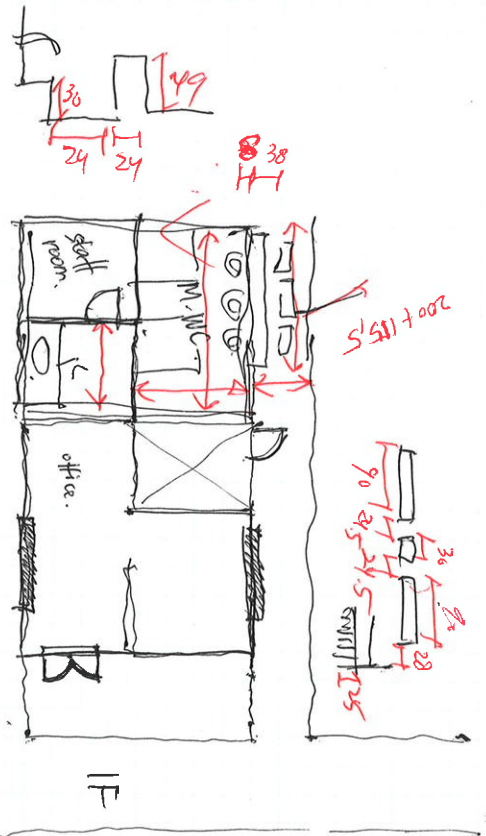

No. 5 Hiroo Mosque (AI)

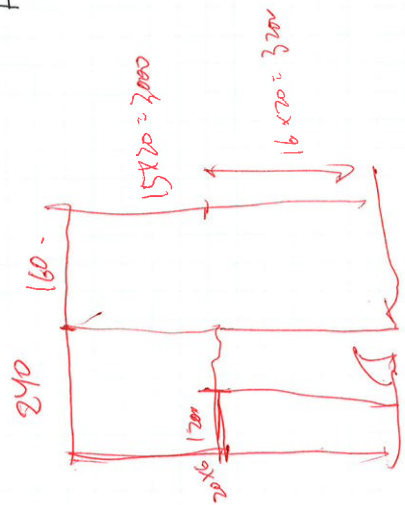
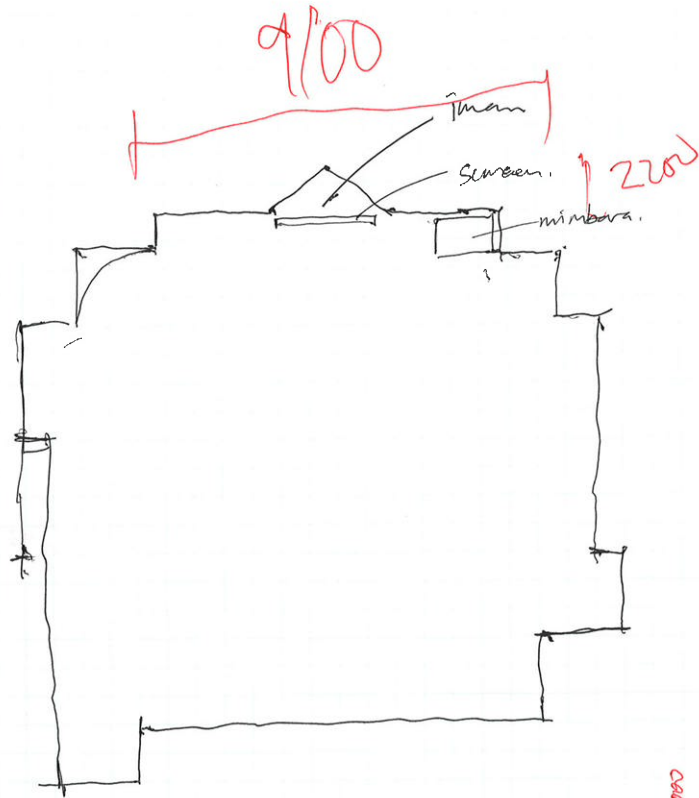

ASSALAM MOSQUE 11/90

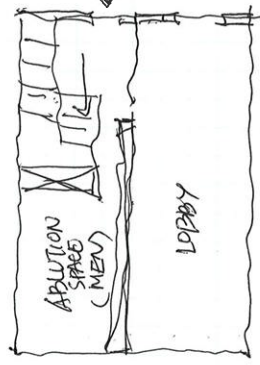

ROAD.

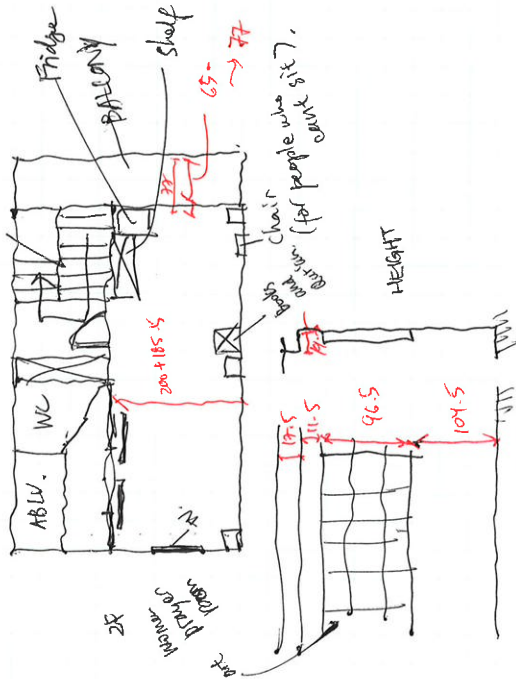

48 + 118 + 14.5

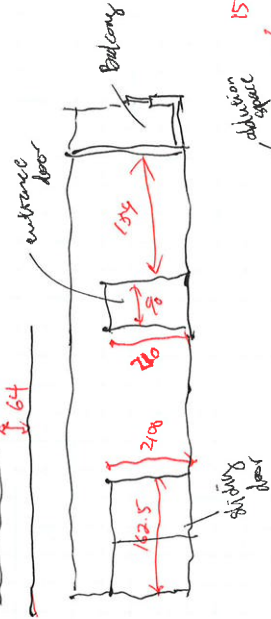
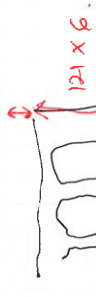

addition space 15 x 5.5



No. 8 Kamata Mosque

KAMATA MOSQUE
ENTRANCE SPACE.

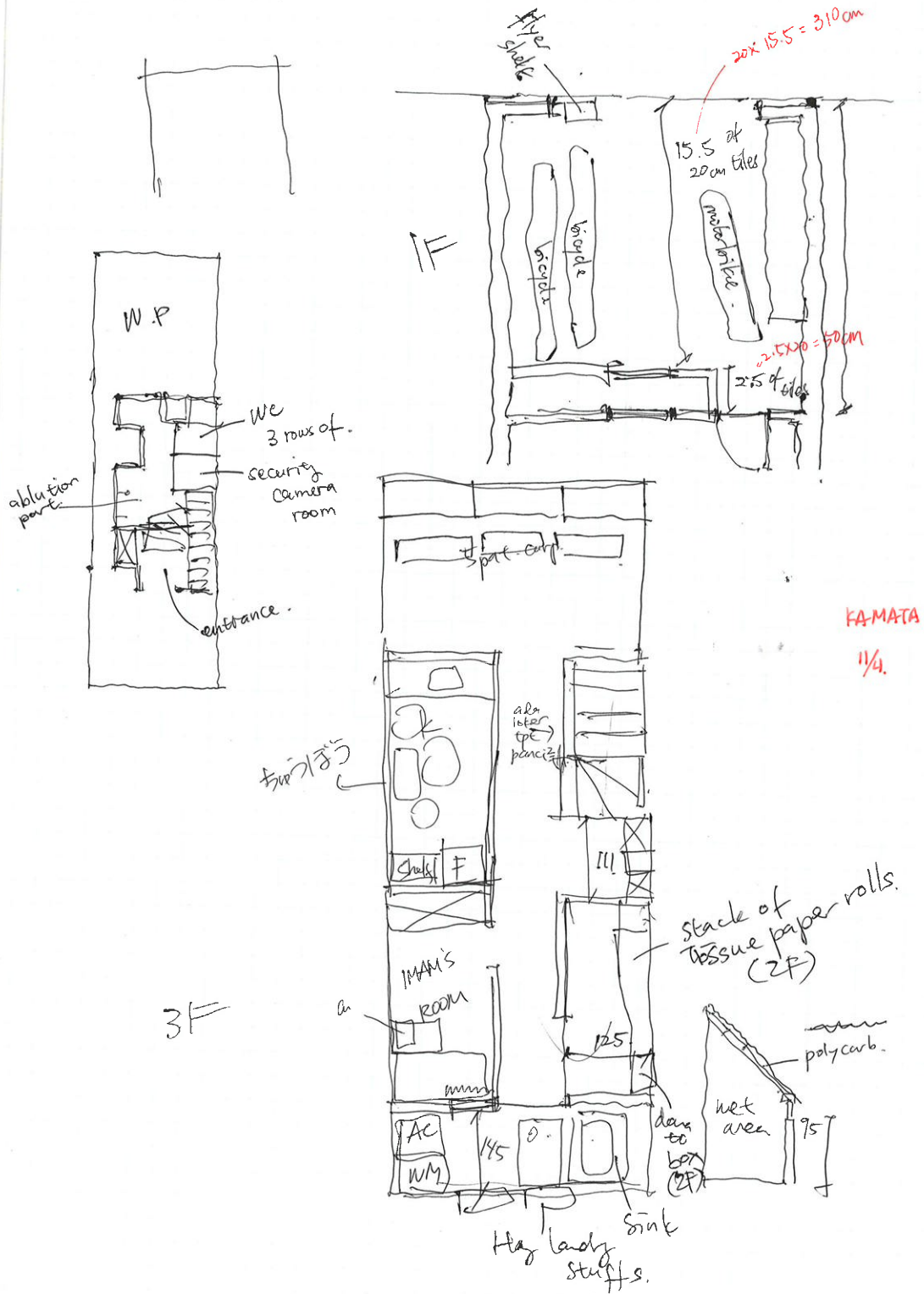

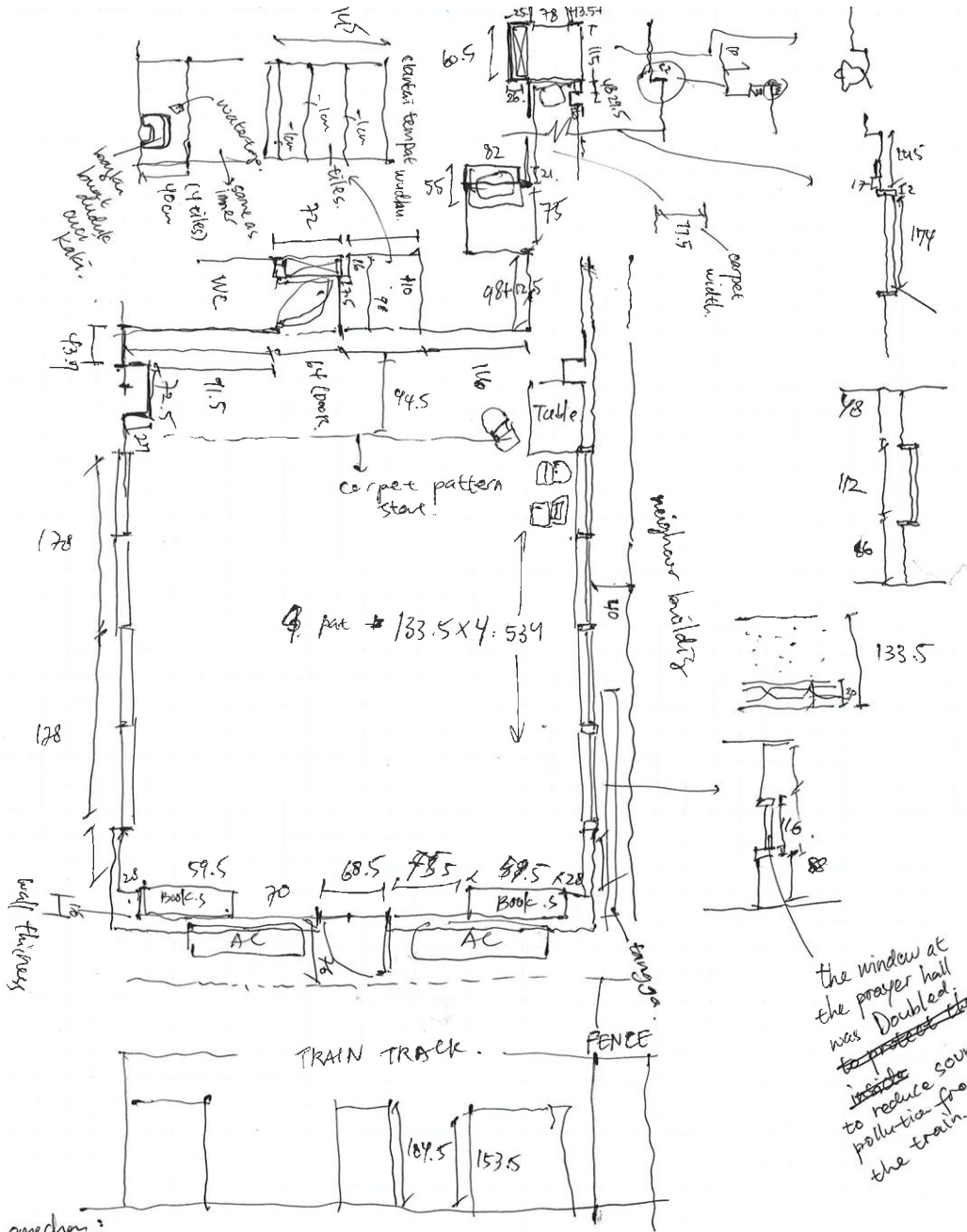

the window at the prayer hall was doubled to ~~protect~~ ~~the~~ ~~inside~~ to reduce sound pollution from the train.

★ from amechan:

How they hack Tokyo??

$$2500 + 150 = 2650$$

KAMATA MOSQUE

"WOMEN PRAYER ROOM" → IF.

IN KAMATA MOSQUE :

- Setiap sholat speaker meneruskan suara Imam setiap sholat.
- 15.30 ada ibu dan anaknya sholat dan "take a break" di mesjid → kado
- The entire building was facing to makkah. (So they didn't have the conflict on orienting the prayer hall.)

Person Met: Mr. Said. / Bangladesh / around ±30 yrs
and talked to today.
in Japan.

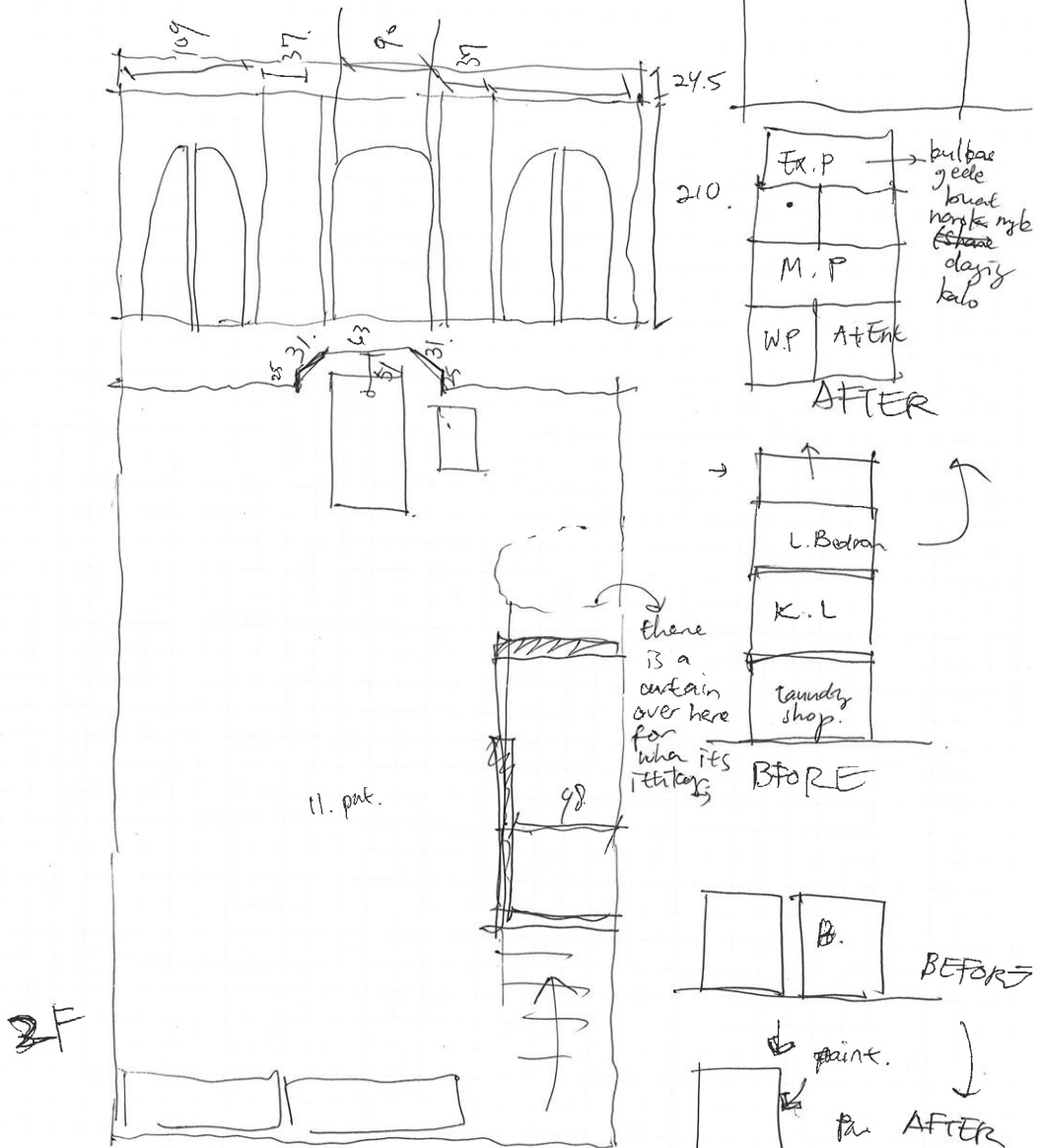

Activities.

- 5 times prayer
- Taraweeh
- Ititcaf (Saturday → Sunday) stay overnight
- Magrib → class about AlQuran, Hadis, and usually after magrib praying. learn arabic, etc (no age limitation)

Eid:

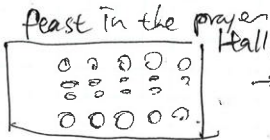

→ Japanese construction company.

No. 9 Al Ikhlas Mosque

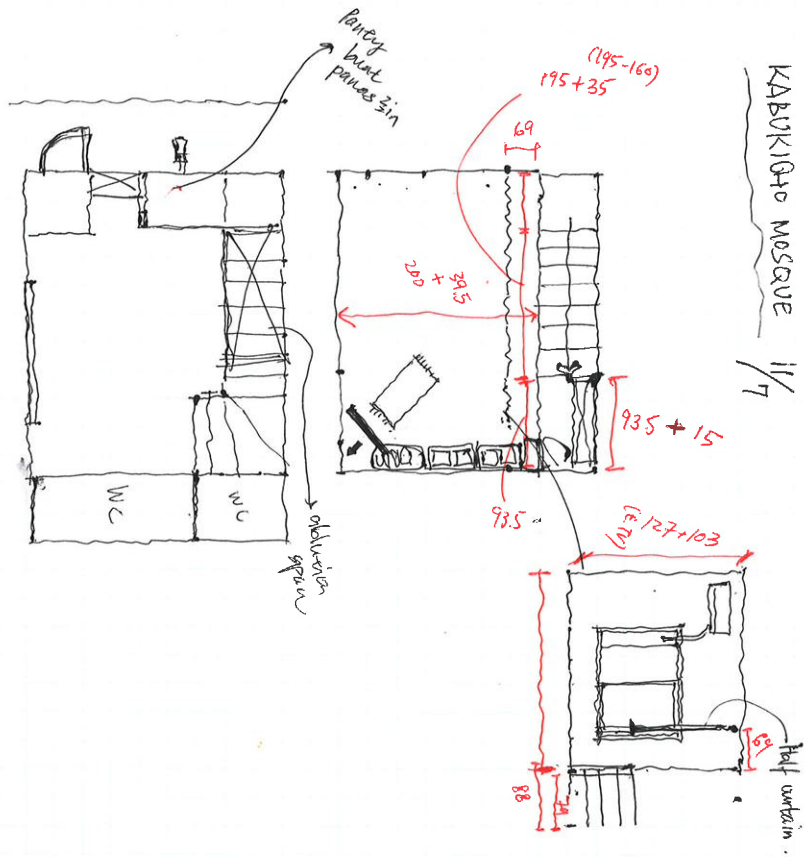

KABUKLOTO MOSQUE 11/7

Aktor:

Fauziah - Maulana Nohi.
11/24 12:00 ~

Many tourists come at Kabukloto mosque.

- o Jadwal Kegiatan di K.M.
- o Kapasitas
- o Siapa aja yg datang?

No. 11 Nusantara Mosque

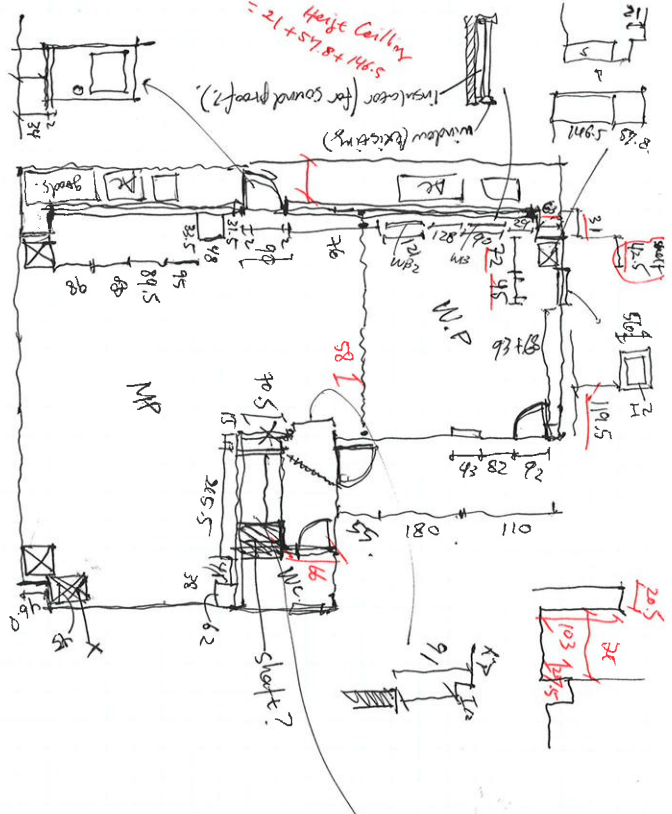

FURNITURE: Paku sendiri dari orang 3 Nusantara (Kendayawan)

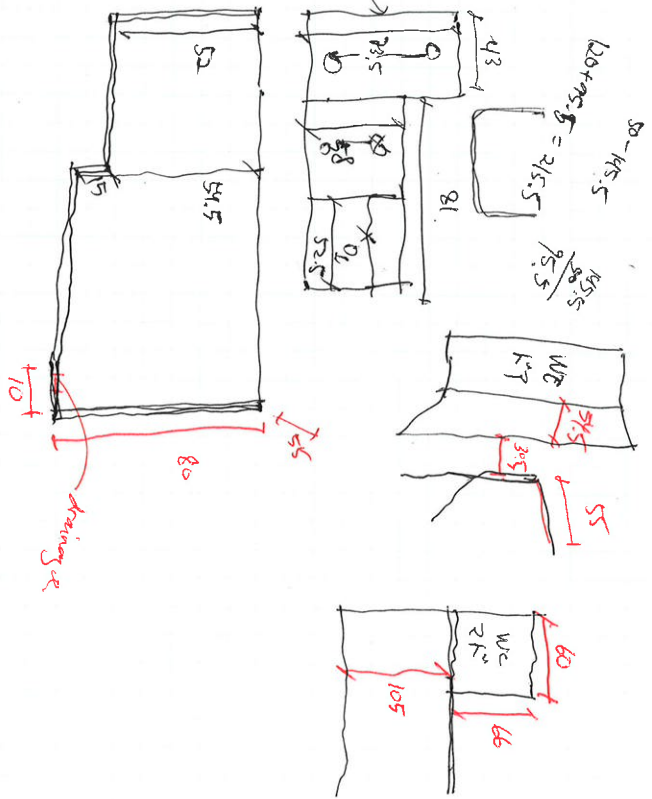
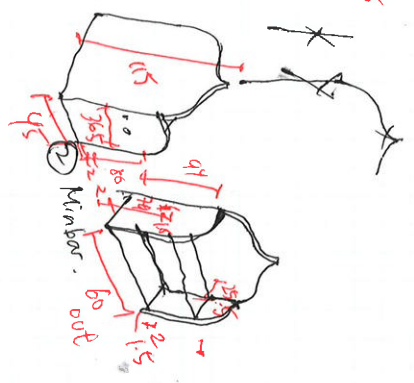
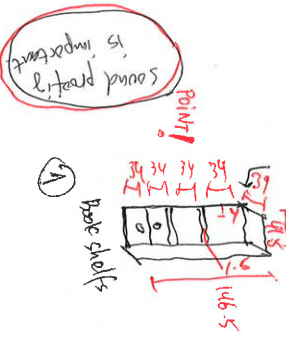

4/5

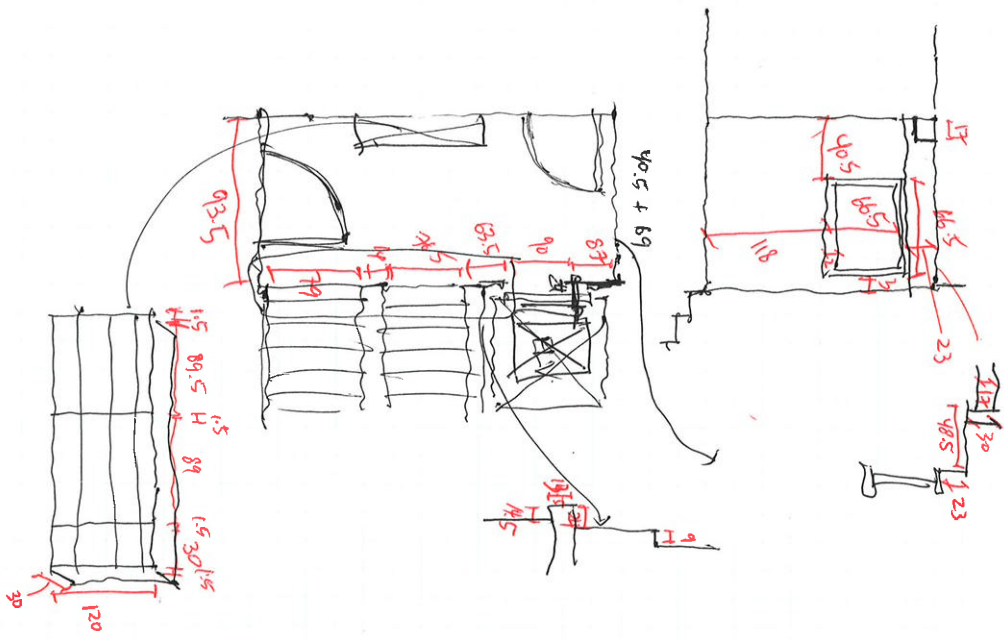

D. Analysis of Study Case

No.	Name	Building Condition	Establishment	Mosque Area (m2)	Floor Number	SALAT Area (m2)	No. of Jamaah		Adaptations of Norm					MISCELLANEOUS ROOMS	Pattern
							Jumaah	Eid	SALAT	WUDHU	MINARET	MIHRAB	MINBAR		
8	KAMATA	OvCC	300	3	85	200	600	Di	Bu(M), Bu(W)	Pa	MR	MB	K, la, Cr, Mlt	E	

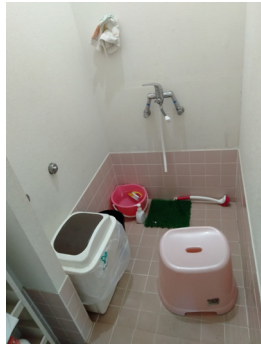

From top left to bottom right: Building, mihrab & minbar, woman's wudhu, man's wudhu

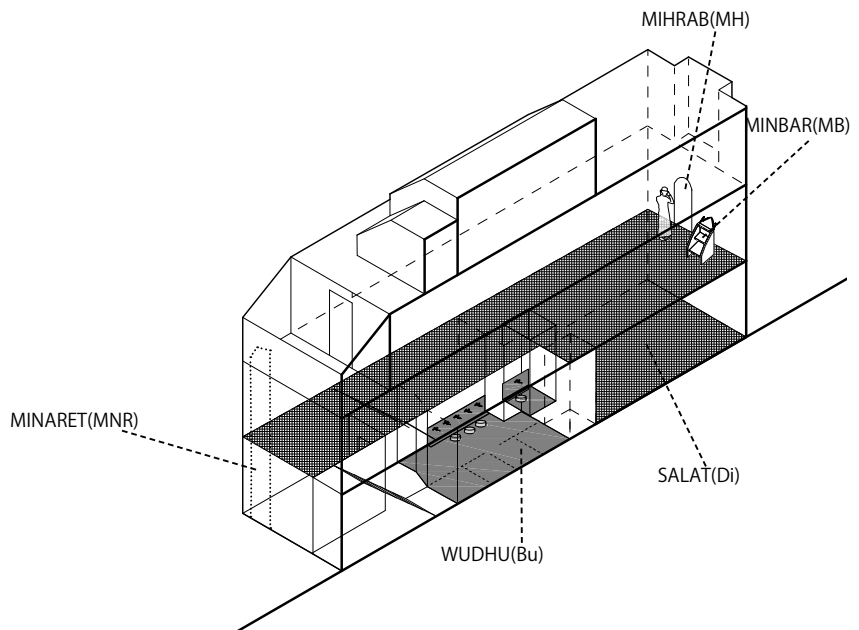
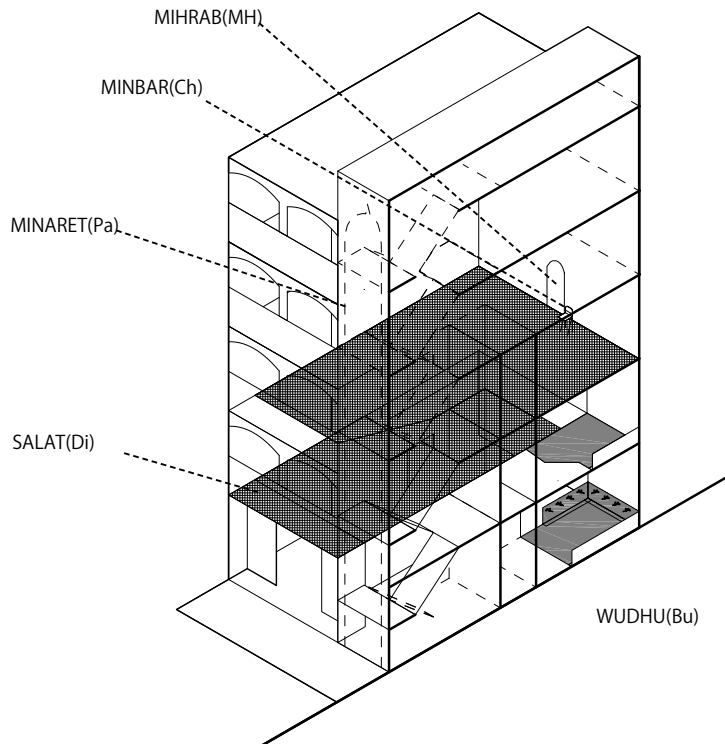

Figure 38.
Axonometric of
Nusantara mosque
(No.11)

No.	Name	Building Condition	Establishment	Mosque Area (m2)	Floor Number	SALAT Area (m2)	No. of Jamaah		Adaptations of Norm			MISCELLANEOUS ROOMS	Pattern		
							Jumaah	Eid	SALAT	WUDHU	MINARET			MIHRAB	MINBAR
7	ASSALAM	Ov	CE	234	5	78	500	1000	Di	Bu(M), Bu(W)	Pa	MR	Ch	K, la, Mit, Cr	E



From top left to bottom right: Building, woman's wudhu, woman's salat, mihrab & minbar



For Hiroo building information is a combination of field survey and google earth

No.	Name	Building Condition	Establishment	Mosque Area (m2)	Floor Number	SALAT Area (m2)	No. of Jamaah		Adaptations of Norm			MISCELLANEOUS ROOMS	Pattern	
							Jumaah	Eid	SALAT	WUDHU	MINARET			MIHRAB
5	HIROO(AI)	NGV	187	6	172	500	500	Me	Bu(M), Bu(W)	-	MR	Ga	K, Cr, Mlt, Lb	C

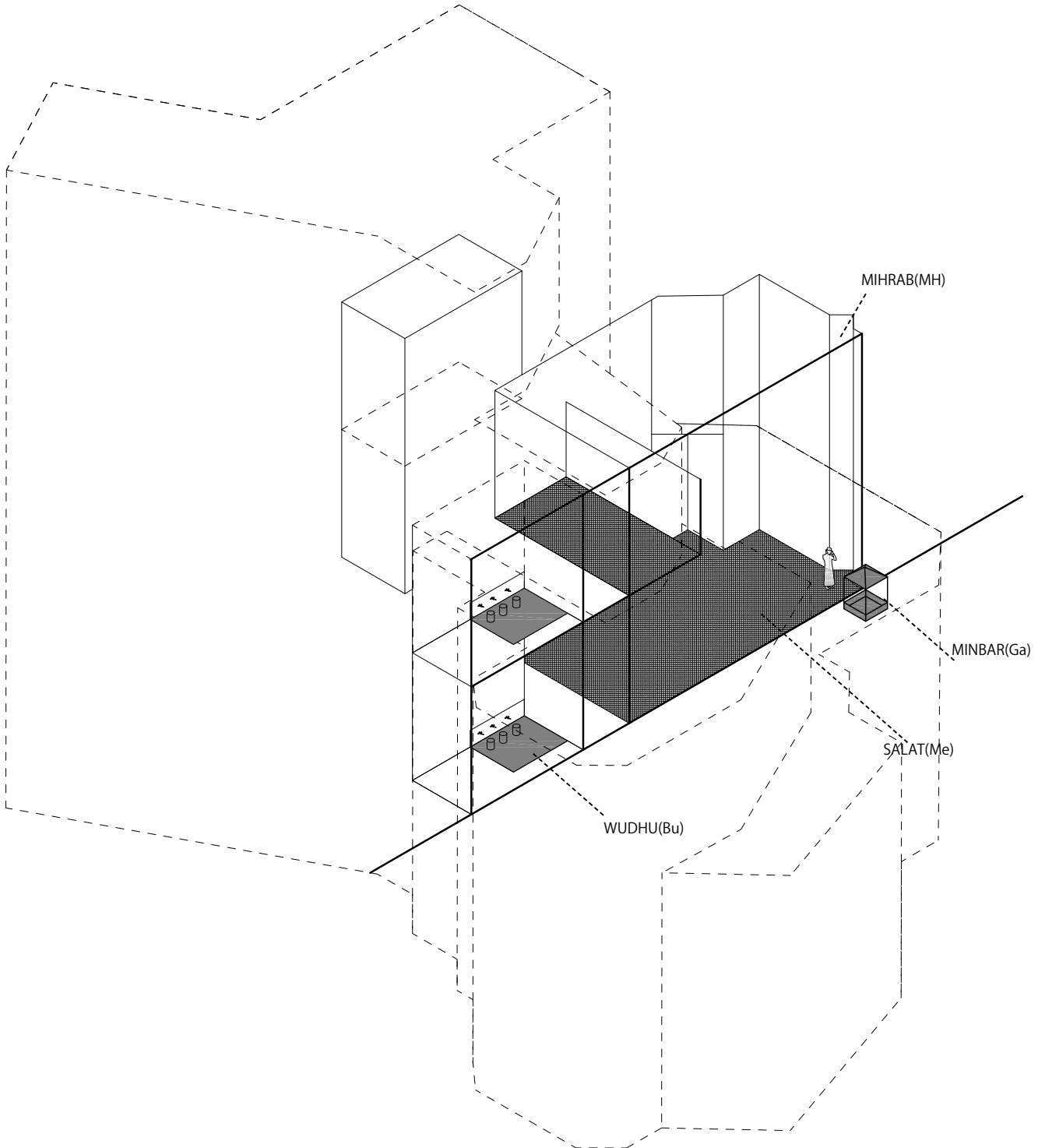



From top to bottom
right: Building, mihrab
& minbar, woman's
salat, woman's wudhu

No.	Name	Building Condition	Establishment	Mosque Area (m2)	Floor Number	SALAT Area (m2)	No. of Jamaah		Adaptations of Norm				MISCELLANEOUS ROOMS	Pattern
							Jumaah	Eid	SALAT	WUDHU	MINARET	MIHRAB		
19	INDONESIA	NGV	154	31	98	200	500	Di	Bu(M).Bu(W)	-	Co	Ch.Po	-	F



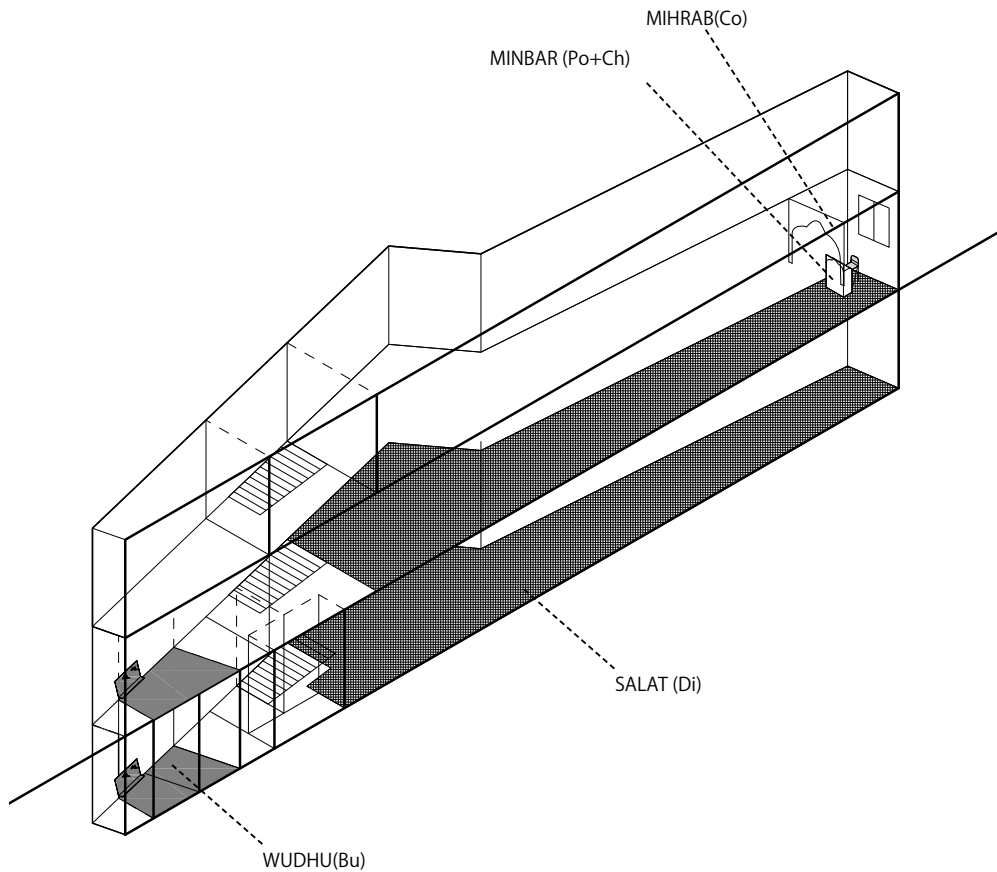

From left to right:
Building, multipurpose room, mihrab & minbar



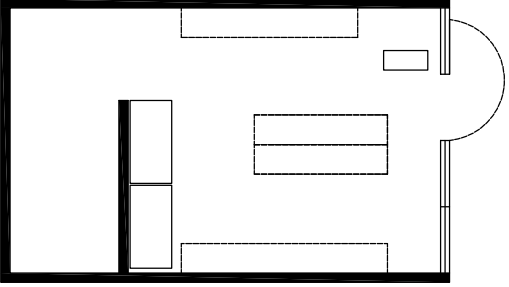

**b. Spatial Practices of South Asian Commonalities
through Food and Prayer in Tokyo**

Nishi Kasai Cluster

Grocery Shop	Cluster Name	Cluster Formation	Space				Practice			Identity				
			Year Est.	Floor	Area (m ²)	Ownership	Open hours	Customer Ethnicity	Other food	Other Items Sold		Owner Ethnicity	Owner Prayer Venue	
Swagat	Nishikasai Cluster	Home Train Station	2005	GF	32	Single	09:00 12:00 15:00 18:00 21:00 24:00	<ul style="list-style-type: none"> ● Nepalese ● Indian ● Bangladeshi ● Sri Lankan ● Pakistani – Afg + Misc. 	–	–	–	Non SA foods Beef Oth.Halal Mt	Indian-Hindu	Hindu Temple
														

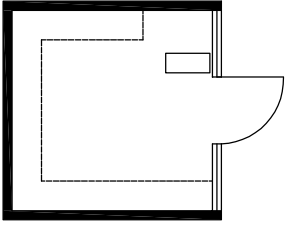
01 m

Grocery Shop	Cluster Name	Cluster Formation	Space				Practice			Identity				
			Year Est.	Floor	Area (m ²)	Ownership	Open hours	Customer Ethnicity	Other food	Other Items Sold		Owner Ethnicity	Owner Prayer Venue	
TMVS	Nishikasai Cluster	Home Train Station	2011	GF	11.5S	ingle	09:00 12:00 15:00 18:00 21:00 24:00	<ul style="list-style-type: none"> ● Nepalese ● Indian ● Bangladeshi ● Sri Lankan ● Pakistani – Afg + Misc. 	–	–	–	Non SA foods Beef Oth.Halal Mt	Indian-Hindu	Hindu Temple
														

01 m

Nishi Kasai Cluster

Grocery Shop	Cluster Name	Cluster Formation	Space				Practice			Identity		
			Year Est.	Floor	Area (m ²)	Ownership	Open hours	Customer Ethnicity	Other food service	Other Items Sold	Owner Ethnicity	Owner Prayer Venue
Kikuchi	Nishikasai Cluster	Home Train Station	2018	1F	30	Single	09:00 12:00 15:00 18:00 21:00 24:00	<ul style="list-style-type: none"> ● Nepalese ● Indian ● Bangladeshi ● Sri Lankan ● Pakistani ● Afg + Misc. 	Restaurant	<ul style="list-style-type: none"> - Non SA foods ○ Beef - Oth.Halal Mt 	Bnd Muslim	Mosque

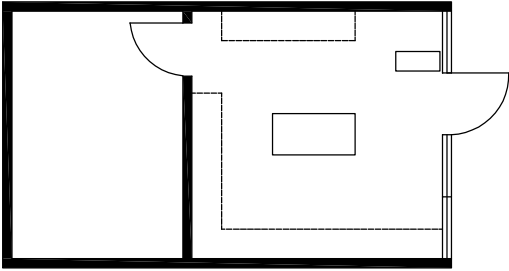

01 m



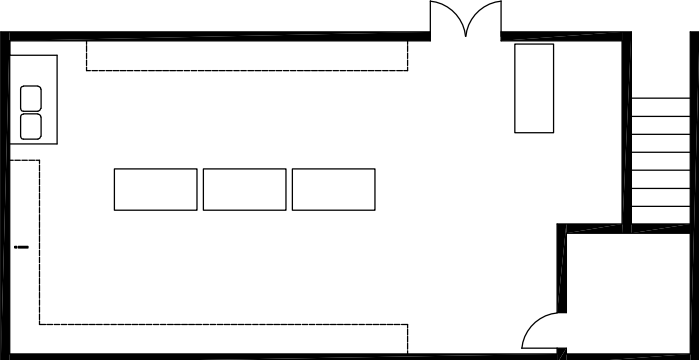

Grocery Shop	Cluster Name	Cluster Formation	Space				Practice			Identity		
			Year Est.	Floor	Area (m ²)	Ownership	Open hours	Customer Ethnicity	Other food service	Other Items Sold	Owner Ethnicity	Owner Prayer Venue
Bappu Bazaar	Nishikasai Cluster	Home Train Station	2017	GF	57	Single	09:00 12:00 15:00 18:00 21:00 24:00	<ul style="list-style-type: none"> ● Nepalese ● Indian ● Bangladeshi ● Sri Lankan ● Pakistani ● Afg + Misc. 	Restaurant	<ul style="list-style-type: none"> - Non SA foods - Beef - Oth.Halal Mt 	Indian-Hindu	Hindu Temple





01 m

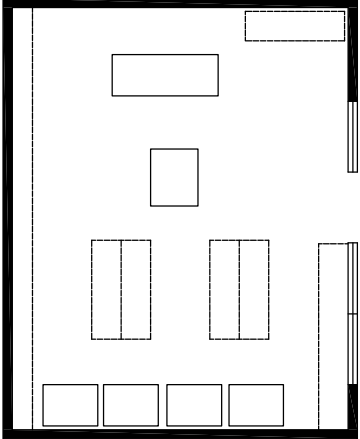

Okachimachi Cluster

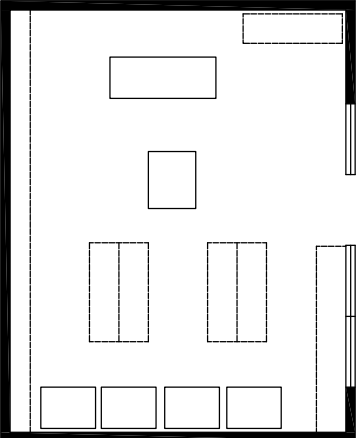
Grocery Shop	Cluster Name	Cluster Formation	Space				Practice			Identity		
			Year Est.	Floor	Area (m ²)	Ownership	Open hours	Customer Ethnicity	Other food service	Other Items Sold	Owner Ethnicity	Owner Prayer Venue
Ambika	Okachimachi Cluster	Market	1998	GF	40	Company	09:00 12:00 15:00 18:00 21:00 24:00	<ul style="list-style-type: none"> ● Nepalese ● Indian ● Bangladeshi ● Sri Lankan ● Pakistani ● Afg + Misc. 	–	– Non SA foods – Beef – Oth.Halal Mt	Indian-Hindu	Hindu Temple
												

Grocery Shop	Cluster Name	Cluster Formation	Space				Practice			Identity		
			Year Est.	Floor	Area (m ²)	Ownership	Open hours	Customer Ethnicity	Other food service	Other Items Sold	Owner Ethnicity	Owner Prayer Venue
StarIndo	Okachimachi Cluster	Market	2006	GF	57.6	Single owner	09:00 12:00 15:00 18:00 21:00 24:00	<ul style="list-style-type: none"> ● Nepalese ● Indian ● Bangladeshi ● Sri Lankan ● Pakistani ● Afg + Misc. 	–	– Non SA foods – Beef – Oth.Halal Mt	Indian - Jain	Jain Temple
												

Okachimachi Cluster

Grocery Shop	Cluster Name	Cluster Formation	Space				Practice			Identity		
			Year Est.	Floor	Area (m ²)	Ownership	Open hours	Customer Ethnicity	Other food service	Other Items Sold	Owner Ethnicity	Owner Prayer Venue
Spicy Food	Okachimachi Cluster	Market	2014	GF	23.8S	Single Owner	09:00 12:00 15:00 18:00 21:00 24:00	<ul style="list-style-type: none"> ● Nepalese ● Indian ● Bangladeshi ● Sri Lankan ● Pakistani ● Afg + Misc. 	—	<input type="radio"/> Non SA foods <input type="radio"/> Beef <input type="radio"/> Oth.Halal Mt	Bangladeshi-Muslim	Mosque

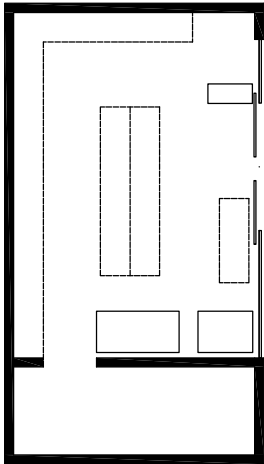

01 m





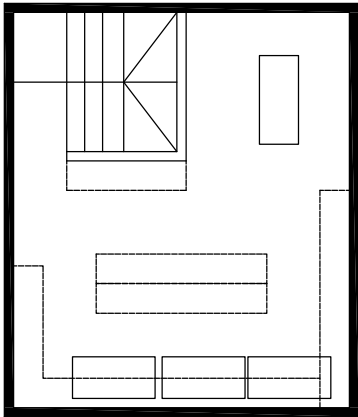

Grocery Shop	Cluster Name	Cluster Formation	Space				Practice			Identity		
			Year Est.	Floor	Area (m ²)	Ownership	Open hours	Customer Ethnicity	Other food service	Other Items Sold	Owner Ethnicity	Owner Prayer Venue
Tokyo Halal	Okachimachi Cluster	Market	2018	2F	30.7	Single Owner	09:00 12:00 15:00 18:00 21:00 24:00	<ul style="list-style-type: none"> ● Nepalese ● Indian ● Bangladeshi ● Sri Lankan ● Pakistani ● Afg + Misc. 	—	<input type="radio"/> Non SA foods <input type="radio"/> Beef <input type="radio"/> Oth.Halal Mt	Bangladeshi-Muslim	Mosque

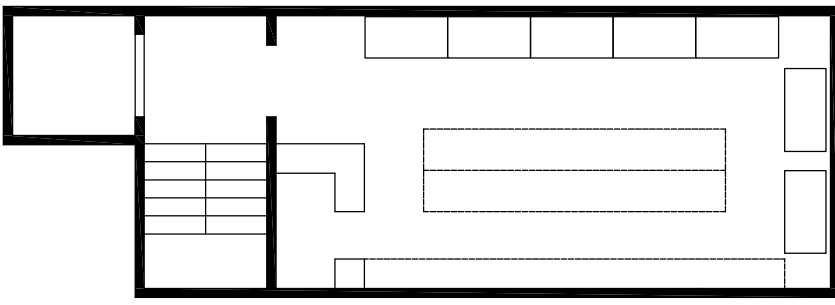

01 m

Ikebukuro Cluster

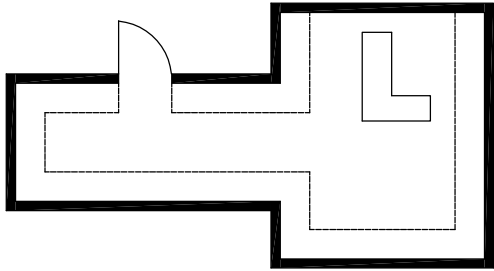
Grocery Shop	Cluster Name	Cluster Formation	Space				Practice			Identity		
			Year Est.	Floor	Area (m ²)	Ownership	Open hours	Customer Ethnicity	Other food service	Other Items Sold		Owner Ethnicity
Al Flah	Ikebukuro Cluster	Religion	1987	4F	43.3C	Company	09:00 12:00 15:00 18:00 21:00 24:00	<ul style="list-style-type: none"> ● Nepalese ● Indian ● Bangladeshi ● Sri Lankan ● Pakistani ● Afg + Misc. 	Restaurant	<input type="radio"/> Non SA foods <input type="radio"/> Beef <input type="radio"/> Oth.Halal Mt	Pakistani-Muslim	Mosque
												
												

Grocery Shop	Cluster Name	Cluster Formation	Space				Practice			Identity		
			Year Est.	Floor	Area (m ²)	Ownership	Open hours	Customer Ethnicity	Other food service	Other Items Sold		Owner Ethnicity
Buddha Fresh	Ikebukuro Cluster	Market	2012	GF	23	Single owner	09:00 12:00 15:00 18:00 21:00 24:00	<ul style="list-style-type: none"> ● Nepalese ● Indian ● Bangladeshi ● Sri Lankan ● Pakistani ● Afg + Misc. 	-	<input type="checkbox"/> Non SA foods <input type="checkbox"/> Beef <input type="checkbox"/> Oth.Halal Mt	Nepalese-Buddhist	At home
												
												

Ikebukuro Cluster

Grocery Shop	Cluster Name	Cluster Formation	Space				Practice			Identity			
			Year Est.	Floor	Area (m ²)	Ownership	Open hours	Customer Ethnicity	Other food service	Other Items Sold		Owner Ethnicity	Owner Prayer Venue
Namaste Mini	Ikebukuro Cluster	Religion	2013	GF	10.4	Single owner	09:00 12:00 15:00 18:00 21:00 24:00	<ul style="list-style-type: none"> ● Nepalese ● Indian ● Bangladeshi ● Sri Lankan ● Pakistani ● Afg + Misc. 	Izakaya	-	<ul style="list-style-type: none"> ○ Non SA foods ○ Beef ○ Oth.Halal Mt 	Nepalese-Hindu	At home

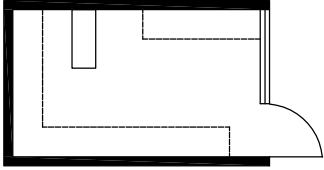

01 m



Grocery Shop	Cluster Name	Cluster Formation	Space				Practice			Identity		
			Year Est.	Floor	Area (m ²)	Ownership	Open hours	Customer Ethnicity	Other food service	Other Items Sold		Owner Ethnicity
MM Halal	Ikebukuro Cluster	Religion	2014	2F	24	Single owner	09:00 12:00 15:00 18:00 21:00 24:00	<ul style="list-style-type: none"> ● Nepalese ● Indian ● Bangladeshi ● Sri Lankan ● Pakistani ● Afg + Misc. 	-	<ul style="list-style-type: none"> ○ Non SA foods ○ Beef ○ Oth.Halal Mt 	Myanmar-Muslim	Mosque

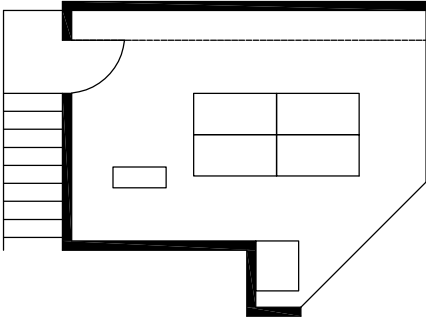

01 m







Ikebukuro Cluster

Grocery Shop	Cluster Name	Cluster Formation	Space				Practice			Identity		
			Year Est.	Floor	Area (m ²)	Ownership	Open hours	Customer Ethnicity	Other food service	Other Items Sold		Owner Ethnicity
Sunshine Halal	Ikebukuro Cluster	Religion	2016	GF-3F	1	Single owner	09:00 12:00 15:00 18:00 21:00 24:00	<ul style="list-style-type: none"> ● Nepalese ● Indian ● Bangladeshi ● Sri Lankan ● Pakistani ● Afg + Misc. 	Kiosk	<input type="radio"/> Non SA foods <input type="radio"/> Beef <input type="radio"/> Oth.Halal Mt	Bangladeshi-Muslim	Mosque

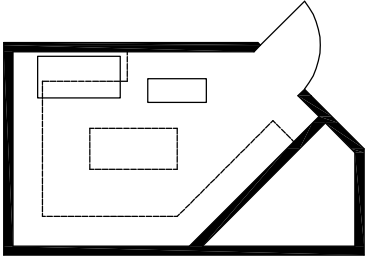
Grocery Shop	Cluster Name	Cluster Formation	Space				Practice			Identity		
			Year Est.	Floor	Area (m ²)	Ownership	Open hours	Customer Ethnicity	Other food service	Other Items Sold		Owner Ethnicity
Rahmania	Ikebukuro Cluster	Religion	2018	GF	12.6	Single owner	09:00 12:00 15:00 18:00 21:00 24:00	<ul style="list-style-type: none"> ● Nepalese ● Indian ● Bangladeshi ● Sri Lankan ● Pakistani ● Afg + Misc. 	-	<input type="radio"/> Non SA foods <input type="radio"/> Beef <input type="radio"/> Oth.Halal Mt	Bangladeshi-Muslim	Mosque

ShinOkubo Cluster

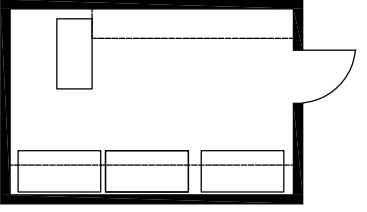
Grocery shop Name	Cluster Name	Cluster Formation	Space				Practice			Identity		
			Year Est.	Floor	Area (m ²)	Ownership	Open hours	Customer Ethnicity	Other food service	Other Items Sold		Owner Ethnicity
Green Nasco	ShinOkubo Cluster	Market Station	1992	GF	16	Company	09:00 12:00 15:00 18:00 21:00 24:00	<ul style="list-style-type: none"> ● Nepalese ● Indian ● Bangladeshi ● Sri Lankan ● Pakistani — Afg + Misc. 	Restaurant	<input type="radio"/> Non SA foods <input type="radio"/> Beef <input type="radio"/> Oth.Halal Mt	Indian-Muslim	Mosque
												
												

Grocery shop Name	Cluster Name	Cluster Formation	Space				Practice			Identity		
			Year Est.	Floor	Area (m ²)	Ownership	Open hours	Customer Ethnicity	Other food service	Other Items Sold		Owner Ethnicity
Nasco Halal	ShinOkubo Cluster	Market	2016	GF	15	Company	09:00 12:00 15:00 18:00 21:00 24:00	<ul style="list-style-type: none"> ● Nepalese ● Indian ● Bangladeshi ● Sri Lankan ● Pakistani — Afg + Misc. 	Restaurant	<input type="radio"/> Non SA foods <input type="radio"/> Beef <input type="radio"/> Oth.Halal Mt	Indian-Muslim	Mosque
												
												

ShinOkubo Cluster

Grocery shop Name	Cluster Name	Cluster Formation	Space				Practice			Identity		
			Year Est.	Floor	Area (m ²)	Ownership	Open hours	Customer Ethnicity	Other food service	Other Items Sold	Owner Ethnicity	Owner Prayer Venue
Barahi	ShinOkubo Cluster	Market Station	2001	GF	16	Single	09:00 12:00 15:00 18:00 21:00 24:00	<ul style="list-style-type: none"> ● Nepalese ● Indian ● Bangladeshi ● Sri Lankan ● Pakistani – Afg + Misc. 	Restaurant	<ul style="list-style-type: none"> <input type="radio"/> Non SA foods <input type="radio"/> Beef <input type="radio"/> Oth.Halal Mt 	Nepalese-Hindu	Home

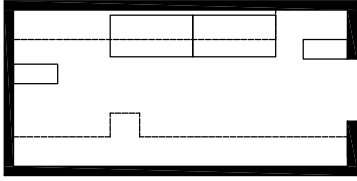

01 m



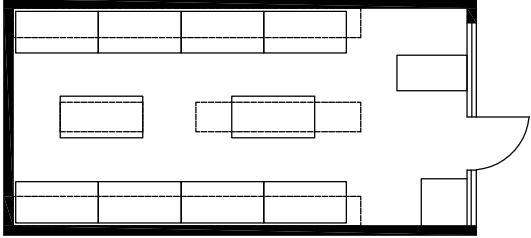

Grocery shop Name	Cluster Name	Cluster Formation	Space				Practice			Identity		
			Year Est.	Floor	Area (m ²)	Ownership	Open hours	Customer Ethnicity	Other food service	Other Items Sold	Owner Ethnicity	Owner Prayer Venue
Al Jannat	ShinOkubo Cluster	Market	2007	GF	28S	ingle	09:00 12:00 15:00 18:00 21:00 24:00	<ul style="list-style-type: none"> ● Nepalese ● Indian ● Bangladeshi ● Sri Lankan ● Pakistani – Afg + Misc. 	Restaurant	<ul style="list-style-type: none"> <input type="radio"/> Non SA foods <input type="radio"/> Beef <input type="radio"/> Oth.Halal Mt 	Indian-Muslim	Mosque





01 m

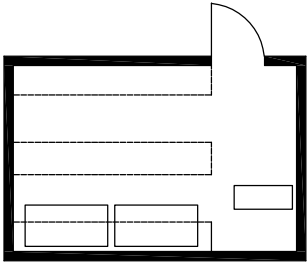

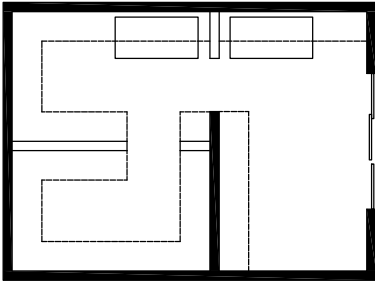

ShinOkubo Cluster

Grocery shop Name	Cluster Name	Cluster Formation	Space				Practice			Identity		
			Year Est.	Floor	Area (m ²)	Ownership	Open hours	Customer Ethnicity	Other food service	Other Items Sold	Owner Ethnicity	Owner Prayer Venue
Shinjuku Halal	ShinOkubo Cluster	Market Station	2012	GF	15	Single	09:00 12:00 15:00 18:00 21:00 24:00	<ul style="list-style-type: none"> ● Nepalese ● Indian ● Bangladeshi ● Sri Lankan ● Pakistani – Afg + Misc. 	Restaurant	<ul style="list-style-type: none"> <input type="radio"/> Non SA foods <input type="radio"/> Beef <input type="radio"/> Oth.Halal Mt 	Bangladeshi - Muslim	Mosque
												
												

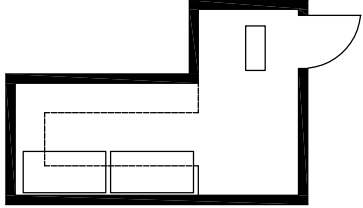

Grocery shop Name	Cluster Name	Cluster Formation	Space				Practice			Identity		
			Year Est.	Floor	Area (m ²)	Ownership	Open hours	Customer Ethnicity	Other food service	Other Items Sold	Owner Ethnicity	Owner Prayer Venue
JB Halal	ShinOkubo Cluster	Market	2014	GF	26	Single	09:00 12:00 15:00 18:00 21:00 24:00	<ul style="list-style-type: none"> ● Nepalese ● Indian ● Bangladeshi ● Sri Lankan ● Pakistani – Afg + Misc. 	–	<ul style="list-style-type: none"> <input type="radio"/> Non SA foods <input type="radio"/> Beef <input type="radio"/> Oth.Halal Mt 	Bangladeshi -Muslim	Mosque
												
												
												



ShinOkubo Cluster

Grocery shop Name	Cluster Name	Cluster Formation	Space				Practice			Identity		
			Year Est.	Floor	Area (m ²)	Ownership	Open hours	Customer Ethnicity	Other food service	Other Items Sold	Owner Ethnicity	Owner Prayer Venue
Kantipur	ShinOkubo Cluster	Market Station	2017	GF	11.2S	ingle	09:00 12:00 15:00 18:00 21:00 24:00	<input type="radio"/> Nepalese <input type="radio"/> Indian <input checked="" type="radio"/> Bangladeshi <input type="radio"/> Sri Lankan <input type="radio"/> Pakistani <input type="radio"/> Afg + Misc.	Restaurant	<input type="radio"/> Non SA foods <input type="radio"/> Beef <input type="radio"/> Oth.Halal Mt	Bangladeshi - Muslim	Mosque
												

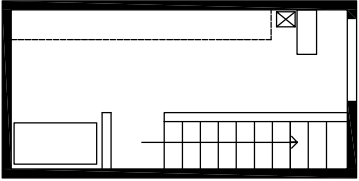

01 m

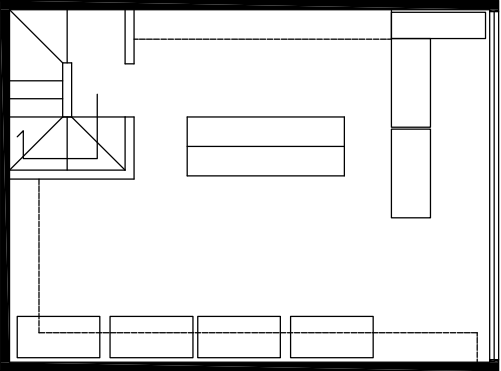
Kamata Cluster

Grocery shop Name	Cluster Name	Cluster Formation	Space				Practice			Identity		
			Year Est.	Floor	Area (m ²)	Ownership	Open hours	Customer Ethnicity	Other food service	Other Items Sold	Owner Ethnicity	Owner Prayer Venue
Nepalese Bazaar	Kamata Cluster	Home Station	2014	2F	11.3S	ingle	09:00 12:00 15:00 18:00 21:00 24:00	Rsd ● Nepalese ● Indian ● Bangladeshi ● Sri Lankan ● Pakistani - Afg + Misc.	&	& Non SA foods & Beef & Oth.Halal Mt	Nepalese-Hindu	Home
												
01 m												

Grocery shop Name	Cluster Name	Cluster Formation	Space				Practice			Identity		
			Year Est.	Floor	Area (m ²)	Ownership	Open hours	Customer Ethnicity	Other food service	Other Items Sold	Owner Ethnicity	Owner Prayer Venue
Indo Bazaar	Kamata Cluster	Home Station	2006	2F4	2	Company	09:00 12:00 15:00 18:00 21:00 24:00	● Nepalese ● Indian ● Bangladeshi ● Sri Lankan ● Pakistani - Afg + Misc.	Restau rant	○ Non SA foods ○ Beef ○ Oth.Halal Mt	Indian-Muslim	Mosque
												
01 m												

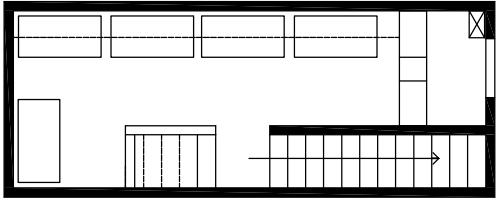
Kamata Cluster

Grocery shop Name	Cluster Name	Cluster Formation	Space				Practice			Identity		
			Year Est.	Floor	Area (m ²)	Ownership	Open hours	Customer Ethnicity	Other food service	Other Items Sold	Owner Ethnicity	Owner Prayer Venue
Asia Bazaar	Kamata Cluster	Home Station	2002	2F	17.5	Single	09:00 12:00 15:00 18:00 21:00 24:00	● Nepalese ● Indian ● Bangladeshi ● Sri Lankan ● Pakistani - Afg + Misc.	Restaurant	& Non SA foods & Beef & Oth. Halal Mt	Nepalese - Hindu	Home
												

01 m

Jujo Cluster



Grocery shop Name	Cluster Name	Cluster Formation	Space				Practice			Identity		
			Year Est.	Floor	Area (m ²)	Ownership	Open hours	Customer Ethnicity	Other food service	Other Items Sold	Owner Ethnicity	Owner Prayer Venue
Baticrom	Jujo Cluster	Home Station	2003	GF	90	Company	09:00 12:00 15:00 18:00 21:00 24:00	<input type="radio"/> Nepalese <input checked="" type="radio"/> Indian <input checked="" type="radio"/> Bangladeshi <input type="radio"/> Sri Lankan <input type="radio"/> Pakistani <input type="radio"/> Afg + Misc.	Restaurant	<input type="radio"/> Non SA foods <input type="radio"/> Beef <input type="radio"/> Oth.Halal Mt	Bangladeshi-Muslim	Mosque

01 m

Grocery shop Name	Cluster Name	Cluster Formation	Space				Practice			Identity		
			Year Est.	Floor	Area (m ²)	Ownership	Open hours	Customer Ethnicity	Other food service	Other Items Sold	Owner Ethnicity	Owner Prayer Venue
SonaliH	Jujo Cluster	Home Station	1998	GF	40	Company	09:00 12:00 15:00 18:00 21:00 24:00	<input checked="" type="radio"/> Nepalese <input checked="" type="radio"/> Indian <input checked="" type="radio"/> Bangladeshi <input type="radio"/> Sri Lankan <input type="radio"/> Pakistani <input type="radio"/> Afg + Misc.	&	<input type="radio"/> Non SA foods <input type="radio"/> Beef <input type="radio"/> Oth.Halal Mt	Bangladeshi-Muslim	Mosque

01 m

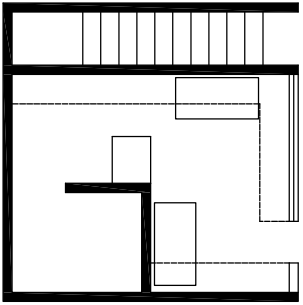
Jujo Cluster



Grocery shop Name	Cluster Name	Cluster Formation	Space				Practice			Identity		
			Year Est.	Floor	Area (m ²)	Ownership	Open hours	Customer Ethnicity	Other food service	Other Items Sold	Owner Ethnicity	Owner Prayer Venue
Mazumdar Halal	Jujo Cluster	Home Station	2016	GF	17.3S	ingle	09:00 12:00 15:00 18:00 21:00 24:00	<ul style="list-style-type: none"> ● Nepalese ● Indian ● Bangladeshi ● Sri Lankan ● Pakistani — Afg + Misc. 	&	<ul style="list-style-type: none"> <input type="radio"/> Non SA foods <input type="radio"/> Beef <input type="radio"/> Oth.Halal Mt 	Bangladeshi-Muslim	Mosque
												

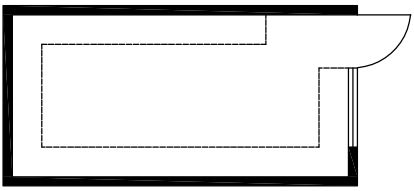

01 m

Grocery shop Name	Cluster Name	Cluster Formation	Space				Practice			Identity		
			Year Est.	Floor	Area (m ²)	Ownership	Open hours	Customer Ethnicity	Other food service	Other Items Sold	Owner Ethnicity	Owner Prayer Venue
Asia Halal	Jujo Cluster	Home Station	2003G	F	15.6C	ompany	09:00 12:00 15:00 18:00 21:00 24:00	<ul style="list-style-type: none"> ● Nepalese ● Indian ● Bangladeshi ● Sri Lankan ● Pakistani — Afg + Misc. 	Restau rant	<ul style="list-style-type: none"> <input type="radio"/> Non SA foods <input type="radio"/> Beef <input type="radio"/> Oth.Halal Mt 	Bangladeshi-Muslim	Mosque
												

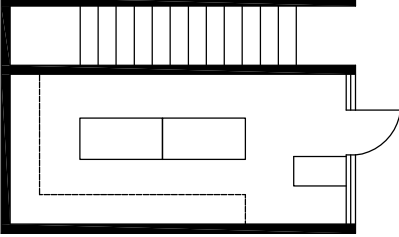
0 1m

Jujo Cluster

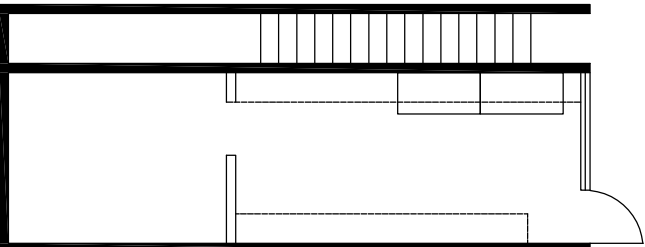
Grocery shop Name	Cluster Name	Cluster Formation	Space				Practice			Identity		
			Year Est.	Floor	Area (m ²)	Ownership	Open hours	Customer Ethnicity	Other food service	Other Items Sold	Owner Ethnicity	Owner Prayer Venue
Sakura Halal	Jujo Cluster	Home Station	2018	GF	14.4S	ingle	09:00	● Nepalese ● Indian ● Bangladeshi ● Sri Lankan ● Pakistani ● Afg + Misc.	&	○ Non SA foods ○ Beef ○ Oth.Halal Mt	Bangla deshi -Muslim	Mosque
							12:00					
												
												

Grocery shop Name	Cluster Name	Cluster Formation	Space				Practice			Identity		
			Year Est.	Floor	Area (m ²)	Ownership	Open hours	Customer Ethnicity	Other food service	Other Items Sold	Owner Ethnicity	Owner Prayer Venue
Jannatul International	Jujo Cluster	Home Station	2018	GF	16.8	Single	09:00	● Nepalese ● Indian ● Bangladeshi ● Sri Lankan ● Pakistani ● Afg + Misc.	Kiosk	○ Non SA foods ○ Beef ○ Oth.Halal Mt	Bangla deshi -Muslim	Mosque
							12:00					
												
												

Jujo Cluster

Grocery shop Name	Cluster Name	Cluster Formation	Space				Practice			Identity		
			Year Est.	Floor	Area (m ²)	Ownership	Open hours	Customer Ethnicity	Other food service	Other Items Sold	Owner Ethnicity	Owner Prayer Venue
Al Barakah	Jujo Cluster	Home Station	2018	GF	17	Single	09:00	● Nepalese	Kiosk	○ Non SA foods	Bangla deshi -Muslim	Mosque
							12:00					
							15:00	● Sri Lankan		○ Oth.Halal Mt		
							18:00	● Pakistani				
							21:00	– Afg + Misc.				
							24:00					

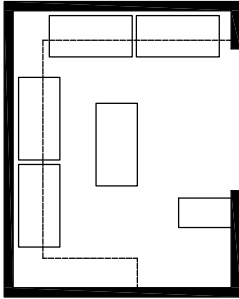

01 m



Grocery shop Name	Cluster Name	Cluster Formation	Space				Practice			Identity		
			Year Est.	Floor	Area (m ²)	Ownership	Open hours	Customer Ethnicity	Other food service	Other Items Sold	Owner Ethnicity	Owner Prayer Venue
Everest	Jujo Cluster	Home Station	2018G	F1	4.5S	ingle	09:00	● Nepalese	—	– Non SA foods	Nepalese -Hindu	Home
							12:00					
							15:00	● Bangladeshi		○ Oth.Halal Mt		
							18:00	● Sri Lankan				
							21:00	● Pakistani				
							24:00	– Afg + Misc.				



01 m



**c. Content Spatial Practices Reimagining a Street into a
Hanryu Shotengai**

No.	Name	Physical Setting					Contents	Appropriation Elements Encountered			Encounter Pattern
		Setback			Const	Over head		E1	E2	E3	
		Shape	Depth	Width (Bldg)							
33b	Noraneke	Setback	2.2	3.5 (19)	Wd	x	Mr	Dr			E1

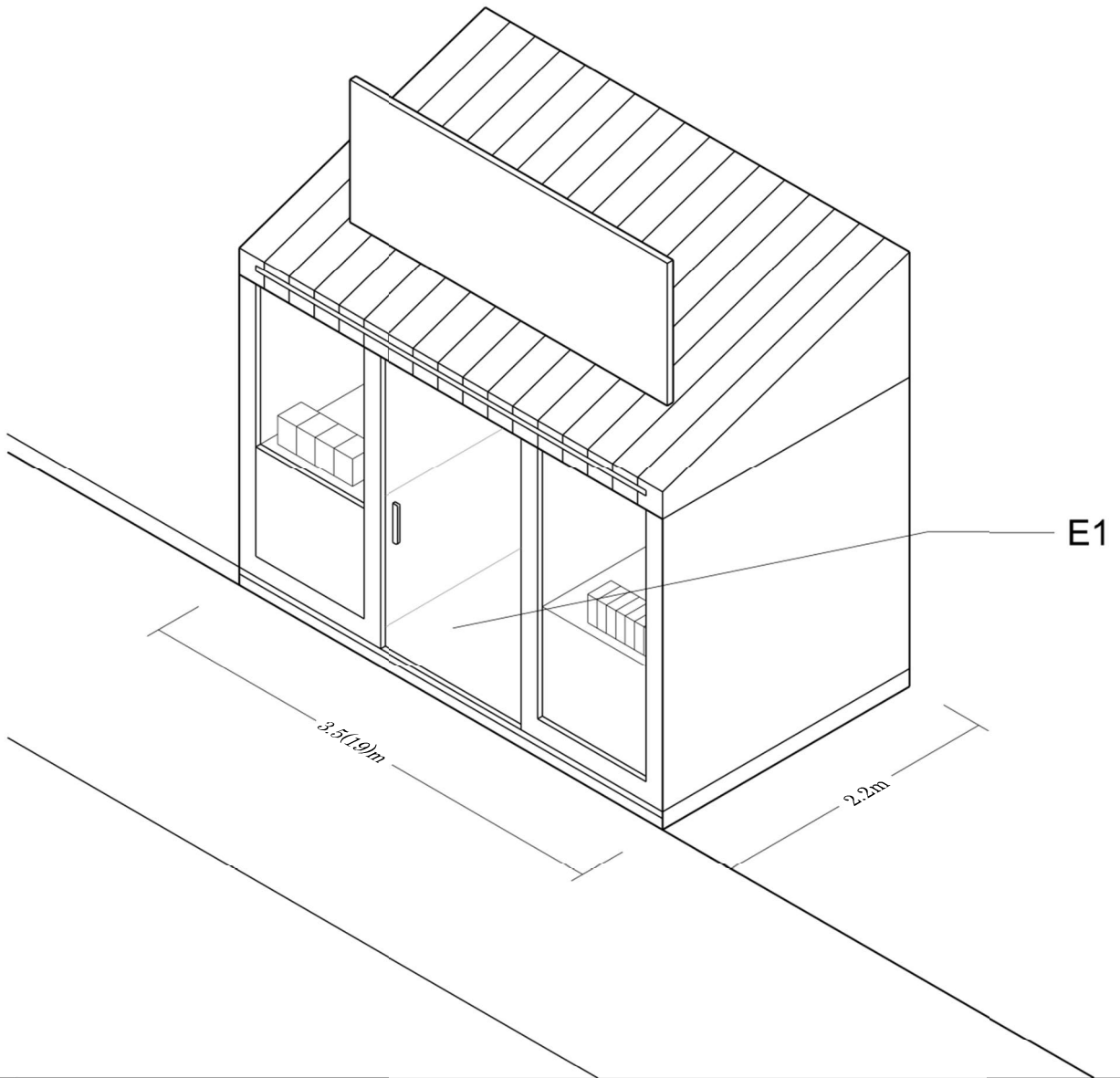



	Door (Dr)	
E1		
E2		
E3		

Fig 4.15 Analysis Example - 33b Mr E1

No.	Name	Physical Setting					Contents	Appropriation Elements Encountered			Encounter Pattern
		Setback			Const	Over head		E1	E2	E3	
		Shape	Depth	Width (Bldg)							
10a	Jongno Hottok	Setback	1	2.5 (8)	RC	x	Rs	Aw,Po	Tkw		E1E2
											
E1		Awning (Aw)		Posters (Po)							
E2		Take away window (Tkw)									
E3											

No.	Name	Physical Setting					Contents	Appropriation Elements Encountered			Encounter Pattern
		Setback			Const	Over head		E1	E2	E3	
		Shape	Depth	Width (Bldg)							
18	Overmacron	Setback	1.5	3 (7)	RC	Pr	Rs	Bn,Tb, Tv	Df, Tkw		E1E2
											
E1		Menu stand-large (Ms)		Menu stand-small (Mm)		Posters (Po)					
E2		Display fridge (Df)		Takeaway window (Tkw)							
E3											

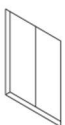
No.	Name	Physical Setting					Contents	Appropriation Elements Encountered			Encounter Pattern
		Setback			Const	Over head		E1	E2	E3	
		Shape	Depth	Width (Bldg)							
6	Uncle Joe's	Setback-side	4.5	8	Tmp		Rs	Aw, Ma, Bn, Fx, Tv, Cd	Tb, Se, Sg, Um, Tt, Tkw		E1E2
											
E1 Awning (Aw), Mat (Ma), Banners (Bn), Faux food (Fx), Television (Tv), Cutouts (Co)											
E2 Table (Tb), Seating (Se), Storage (Sg), Umbrella (Um), Tent (Tt), Take away window (Tkw)											
E3											

No.	Name	Physical Setting					Contents	Appropriation Elements Encountered			Encounter Pattern
		Setback			Const	Over head		E1	E2	E3	
		Shape	Depth	Width (Bldg)							
40a	Hana	Setback	2.2	8 (18)	Wd		Fs	Aw, Po	Tb, Ce, Hf		E1E2
											
E1 Awning (Aw), Posters (Po)											
E2 Table (Tb), Counter (Ce), Hanging frame (Hf)											
E3											

No.	Name	Physical Setting					Contents	Appropriation Elements Encountered			Encounter Pattern
		Setback			Const	Over head		E1	E2	E3	
		Shape	Depth	Width (Bldg)							
7b	美&知	Setback	1.2	2.3 (9)	RC		Co	Aw, Du, Ma	Op	E1E3	

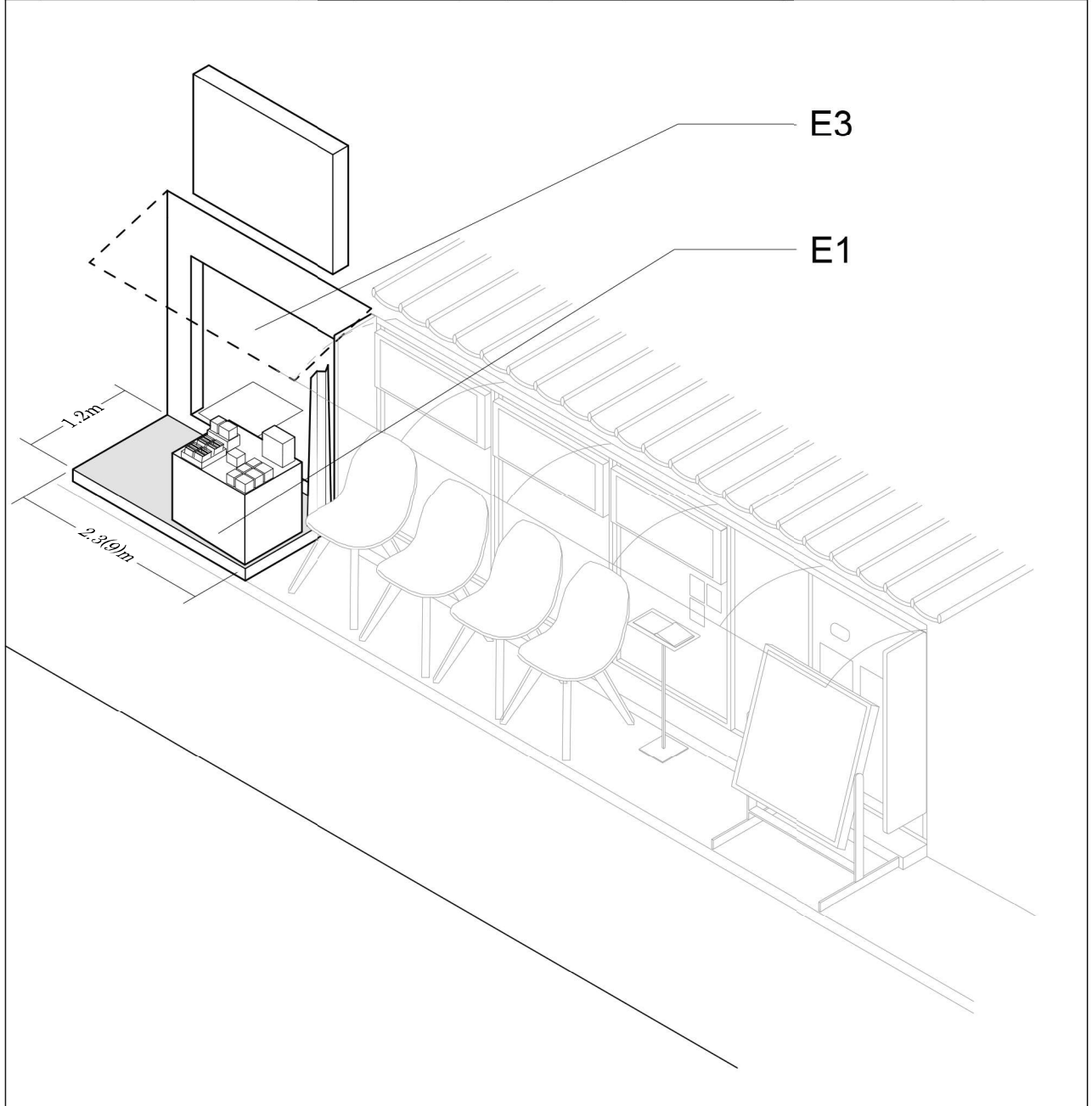



E1	Awning (Aw)	Mat (Ma)	Display (Du)	
E2				
E3	Opening (Op)			

No.	Name	Physical Setting					Contents	Appropriation Elements Encountered			Encounter Pattern
		Setback			Const	Over head		E1	E2	E3	
		Shape	Depth	Width (Bldg)							
29	韓マウン2F	Setback	2	1.5	RC	x	Rs	Ma,Tv		Str	E1E3
											
E1 Mat (Ma), Television monitor (Tv)											
E2											
E3 Stair (Str)											

No.	Name	Physical Setting					Contents	Appropriation Elements Encountered			Encounter Pattern
		Setback			Const	Over head		E1	E2	E3	
		Shape	Depth	Width (Bldg)							
26	Moise	Setback	1	3.8 (10)	RC	x	Rs	Ms,Mf,Ma,Po,Bn		Dr	E1E3
											
E1 Menu stand-large (Ms), Menu stand-folding (Mf), Mat (Ma), Posters (Po), Banners (Bn)											
E2											
E3 Door (Dr)											

No.	Name	Physical Setting					Contents	Appropriation Elements Encountered			Encounter Pattern
		Setback			Const	Over head		E1	E2	E3	
		Shape	Depth	Width (Bldg)							
27c	青松新	Setback-side	1	2 (14)	RC	Pr	Rs	Mf, Po, Tv		Dr	E1E3
											
E1 Menu stand-folding (Mf), Posters (Po), Television (Tv)											
E2											
E3 Door (Dr)											

No.	Name	Physical Setting					Contents	Appropriation Elements Encountered			Encounter Pattern
		Setback			Const	Over head		E1	E2	E3	
		Shape	Depth	Width (Bldg)							
28	Kollabo	Setback	1.2	3.8 (10)	RC		Rs	Ms,Mf,Ma,Po,Fx		Dr	E1E3
											
E1 Menu stand (Ms), Menu stand-folding (Mf), Mats (Ma), Posters (Po), Faux food (Fx)											
E2											
E3 Door (Dr)											

No.	Name	Physical Setting					Contents	Appropriation Elements Encountered			Encounter Pattern
		Setback			Const	Over head		E1	E2	E3	
		Shape	Depth	Width (Bldg)							
23	コルモク	Cul-de-sac	1	9.6	Wd	x	Rs	Ms		Dr	E1E3
											
E1 Menu stand-folding (Mf), Posters (Po), Television (Tv)											
E2											
E3 Door (Dr)											

No.	Name	Physical Setting					Contents	Appropriation Elements Encountered			Encounter Pattern
		Setback			Const	Over head		E1	E2	E3	
		Shape	Depth	Width (Bldg)							
23	Seoul Cafe	Cul-de-sac	1	9.6	RC	x	Rs	Po		Str	E1E3
											
E1 Poster (Po)											
E2											
E3 Stair (Str)											



No.	Name	Physical Setting					Contents	Appropriation Elements Encountered			Encounter Pattern
		Setback			Const	Over head		E1	E2	E3	
		Shape	Depth	Width (Bldg)							
17a	Factory 45	Setback	5.5	1.3 (12)	RC	Pr	Rs	Ms, Mm, Mf		Str	E1E3
											
E1 Menu stand (Ms), Menu stand-small (Mm), Menu stand-folding (Mf)											
E2											
E3 Stair (Str)											

No.	Name	Physical Setting					Contents	Appropriation Elements Encountered			Encounter Pattern
		Setback			Const	Over head		E1	E2	E3	
		Shape	Depth	Width (Bldg)							
40b	Fashion Sense	Setback	1	3.3 (12)	Wd	x	Fs	Aw		Dr	E1E3
 											
E1 Awning (Aw)											
E2											
E3 Door (Dr)											

No.	Name	Physical Setting					Contents	Appropriation Elements Encountered			Encounter Pattern
		Setback			Const	Over head		E1	E2	E3	
		Shape	Depth	Width (Bldg)							
27a	スマイルコスメ	Setback	1.3	2 (14)	RC	Pr	Co	Hf		Op	E1E3
											
E1 Hanging frame											
E2											
E3 Opening (Op)											

No.	Name	Physical Setting					Contents	Appropriation Elements Encountered			Encounter Pattern
		Setback			Const	Over head		E1	E2	E3	
		Shape	Depth	Width (Bldg)							
40c	ShezCosme	Setback	1.3	2 (14)	Wd		Co	Aw, Tr		Dr	E1E3
											
E1 Awning (Aw), Trolley (Tr)											
E2											
E3 Door (Dr)											

No.	Name	Physical Setting					Contents	Appropriation Elements Encountered			Encounter Pattern
		Setback			Const	Over head		E1	E2	E3	
		Shape	Depth	Width (Bldg)							
35	Moiza	Setback	1.2	7	Wd	Ev	Mr		Tr, Gm	Dr	E2E3

E1
E2 Trolley (Tr), Game machines (Gm)
E3 Opening (Op)

No.	Name	Physical Setting					Contents	Appropriation Elements Encountered			Encounter Pattern
		Setback			Const	Over head		E1	E2	E3	
		Shape	Depth	Width (Bldg)							
17b	Gallery 45	Setback	5.5	5.4 (12)	RC	x	Co		Aw, Tr, Du, Um	Op	E2E3



E1
E2 Awning (Aw), Trolley (Tr), Display unit (Du), Umbrella (Um)
E3 Opening (Op)

No.	Name	Physical Setting					Contents	Appropriation Elements Encountered			Encounter Pattern
		Setback			Const	Over head		E1	E2	E3	
		Shape	Depth	Width (Bldg)							
6	カントンの思い出	Setback	1.7	2.9(8.7)	RC		Rs	Aw, Ms, Ma	Mm, Se	Dr	E1E2E3a
											
E1 Awning (Aw), Menu stand (Ms), Mats (Ma)											
E2 Seating (Se), Menu stand-small (Mm)											
E3 Door (Dr)											

No.	Name	Physical Setting					Contents	Appropriation Elements Encountered			Encounter Pattern
		Setback			Const	Over head		E1	E2	E3	
		Shape	Depth	Width (Bldg)							
10b	Itaro	Setback	1	5.8 (8)	RC	Pr	Rs	Ms, Mm, Ma, Po, Ssy	Gr	Dr	E1E2E3a
											
E1 Menu stand (Ms), Menu stand-small (Mm), Posters (Po), Mats (Ma), Sound system Ssy											
E2 Grocery shelf (Gr)											
E3 Door (Dr)											

No.	Name	Physical Setting					Contents	Appropriation Elements Encountered			Encounter Pattern
		Setback			Const	Over head		E1	E2	E3	
		Shape	Depth	Width (Bldg)							
20	マッコリの物語	Setback	1.3	4(9)	RC	Ev	Rs	Mm,Ms,Ma,Bn	As,Sg	Dr	E1E2E3a



E1	Menu stand-small (Mm), Menu stand (Ms), Mats (Ma), Banner (Bn)
E2	Ashtray (As), Storage (Sg)
E3	Door (Dr)

No.	Name	Physical Setting					Contents	Appropriation Elements Encountered			Encounter Pattern
		Setback			Const	Over head		E1	E2	E3	
		Shape	Depth	Width (Bldg)							
19	豚マダン	Setback	1.6	12	RC	x	Rs	Po, Cn	Ce,Tb,Se,Tkw	Dr	E1E2E3a





E1	Posters (Po), Curtain (Cn)
E2	Counter (Ce), Tables (Tb), Seating (Se), Take away window (Tkw)
E3	Door (Dr)

No.	Name	Physical Setting					Contents	Appropriation Elements Encountered			Encounter Pattern
		Setback			Const	Over head		E1	E2	E3	
		Shape	Depth	Width (Bldg)							
2	Tong-chan	Setback	2	19	RC		Rs	Aw,Ms,Ma,Po	Tb,Se,Tkw	Dr	E1E2E3a





E1	Awning (Aw), Menu stand (Ms), Mats (Ma), Posters (Po)
E2	Ashtray (As), Storage (Sg)
E3	Door (Dr)

No.	Name	Physical Setting					Contents	Appropriation Elements Encountered			Encounter Pattern
		Setback			Const	Over head		E1	E2	E3	
		Shape	Depth	Width (Bldg)							
8b	Hanam Pig	Setback	2	12	RC	Pr	Rs	Ms,Mm,Ma,Po	Se	Dr	E1E2E3a





E1	Menu stand (Ms), Menu stand-small (Mm), Mats (Ma), Posters (Po)
E2	Seating (Se)
E3	Door (Dr)

No.	Name	Physical Setting					Contents	Appropriation Elements Encountered			Encounter Pattern
		Setback			Const	Over head		E1	E2	E3	
		Shape	Depth	Width (Bldg)							
13	カントンの思い出 029店	Setback	1.7	4.7 (20)	RC		Rs	Aw,Ms,Ma	Se	Dr	E1E2E3a
											
E1 Awning (Aw), Menu stand (Ms), Mats (Ma)											
E2 Seating (Se)											
E3 Door (Dr)											

No.	Name	Physical Setting					Contents	Appropriation Elements Encountered			Encounter Pattern
		Setback			Const	Over head		E1	E2	E3	
		Shape	Depth	Width (Bldg)							
14	マニト	Setback	1.7	3.8 (20)	RC		Rs	Aw,Ms,Ma,Po	Se, As,Be,Sg	Dr	E1E2E3a
											
E1 Awning (Aw), Menu stand (Ms), Mats (Ma), Posters (Po)											
E2 Seating (Se), Ashtray, Beer (Be), Storage (Sg)											
E3 Door (Dr)											

No.	Name	Physical Setting					Contents	Appropriation Elements Encountered			Encounter Pattern
		Setback			Const	Over head		E1	E2	E3	
		Shape	Depth	Width (Bldg)							
15	ドヤジ屋	Setback	1.7	3.8 (20)	RC		Rs	Aw,Ms,Ma,Po	As,Se,Sg	Dr	E1E2E3a
											
E1 Awning (Aw), Menu stand (Ms), Mats (Ma), Posters (Po)											
E2 Ashtray (As), Seating (Se), Storage (Sg)											
E3 Door (Dr)											

No.	Name	Physical Setting					Contents	Appropriation Elements Encountered			Encounter Pattern
		Setback			Const	Over head		E1	E2	E3	
		Shape	Depth	Width (Bldg)							
24	ヨブの王豚塩焼	Setback	2	7	RC	x	Rs	Ms,Ma,Po,Bn,Tv	Se,Be,Dw	Dr	E1E2E3a
											
E1 Menu stand (Ms), Mats (Ma), Posters (Po), Banner (Bn), Television monitors (Tv)											
E2 Seating (Se), Beer storage (Be), Display window (Dw)											
E3 Door (Dr)											

No.	Name	Physical Setting					Contents	Appropriation Elements Encountered			Encounter Pattern
		Setback			Const	Over head		E1	E2	E3	
		Shape	Depth	Width (Bldg)							
25	Kanton JMT	Setback	2	11.1 (14)	RC	Pr	Rs	Ms,Mm,Ma,Po	Se,Df	Dr	E1E2E3a



E1	Menu stand (Ms), Menu stand-small (Mm), Mats (Ma), Posters (Po)
E2	Seating (Se), Display fridge (Df)
E3	Door (Dr)

No.	Name	Physical Setting					Contents	Appropriation Elements Encountered			Encounter Pattern
		Setback			Const	Over head		E1	E2	E3	
		Shape	Depth	Width (Bldg)							
30	Dongnara	Setback	2	5 (38)	RC	x	Rs	Ma, Po	Se	Dr	E1E2E3a



E1	Mats (Ma), Posters (Po)
E2	Seating (Se)
E3	Door (Dr)

No.	Name	Physical Setting					Contents	Appropriation Elements Encountered			Encounter Pattern
		Setback			Const	Over head		E1	E2	E3	
		Shape	Depth	Width (Bldg)							
21	75chacha	Cul-de-sac	1	9.3	Wd	Ev	Rs	Ms	Tb,Se	Dr	E1E2E3a



E1	Menu stand (Ms)
E2	Tables, (Tb), Seating (Se)
E3	Door (Dr)

No.	Name	Physical Setting					Contents	Appropriation Elements Encountered			Encounter Pattern
		Setback			Const	Over head		E1	E2	E3	
		Shape	Depth	Width (Bldg)							
22	Seoul Tiramisu	Cul-de-sac	1	3.8	Wd	x	Rs	Po	Tkw	Dr	E1E2E3a



E1	Posters (Po)
E2	Take away window (Tkw)
E3	Door (Dr)

No.	Name	Physical Setting					Contents	Appropriation Elements Encountered			Encounter Pattern
		Setback			Const	Over head		E1	E2	E3	
		Shape	Depth	Width (Bldg)							
3	宋家カムジャタン 別館	Setback-gap	1.5	5.9	RC	Ev	Rs	Ms, Ma, Ma	Se, Tt	Dr	E1E2E3a



E1	Menu stand (Ms), Menu stand-folding (Mf), Mats (Ma)
E2	Seating (Se), Tent (Tt)
E3	Door (Dr)

No.	Name	Physical Setting					Contents	Appropriation Elements Encountered			Encounter Pattern
		Setback			Const	Over head		E1	E2	E3	
		Shape	Depth	Width (Bldg)							
27b	Kim's Cosme	Setback	1.3	5 (14)	RC	Pr	Co	Hf	Du, Sh	Op	E1E2E3a





E1	Hanging frame (Hf)
E2	Display unit (Du), Shelving (Sh)
E3	Opening (Op)

No.	Name	Physical Setting					Contents	Appropriation Elements Encountered			Encounter Pattern
		Setback			Const	Over head		E1	E2	E3	
		Shape	Depth	Width (Bldg)							
41a	Plac Shoes	Setback	1.3	4 (28)	RC	Pr	Fs	Ma	Du	Dr	E1E2E3a
											
E1 Mats (Ma)											
E2 Display units (Du)											
E3 Door (Dr)											

No.	Name	Physical Setting					Contents	Appropriation Elements Encountered			Encounter Pattern
		Setback			Const	Over head		E1	E2	E3	
		Shape	Depth	Width (Bldg)							
41c	Popskin	Setback	1.3	3.8 (28)	RC	Pr	Co	Ma	Tr,Du,Ds,Su	Dr	E1E2E3a
											
E1 Mats (Ma)											
E2 Trolley (Tr), Display unit (Du), Display shelf (Ds), Standing unit (Su)											
E3 Door (Dr)											

No.	Name	Physical Setting					Contents	Appropriation Elements Encountered			Encounter Pattern
		Setback			Const	Over head		E1	E2	E3	
		Shape	Depth	Width (Bldg)							
50	BN the Shiny	Setback	1.3	3.3 (9)	RC		Co	Aw	Tb,Ct	Op	E1E2E3a
											
E1 Awning (Aw)											
E2 Tables (Tb), Cartons (Ct)											
E3 Opening (Op)											

No.	Name	Physical Setting					Contents	Appropriation Elements Encountered			Encounter Pattern
		Setback			Const	Over head		E1	E2	E3	
		Shape	Depth	Width (Bldg)							
51	美肌工房 自然の森	Setback	1.4	4	S		Co	Aw, Tv	Tr,Du	Dr	E1E2E3a
											
E1 Awning (Aw), Television monitor (Tv)											
E2 Trolley (Tr), Display unit (Du)											
E3 Door (Dr)											

No.	Name	Physical Setting					Contents	Appropriation Elements Encountered			Encounter Pattern
		Setback			Const	Over head		E1	E2	E3	
		Shape	Depth	Width (Bldg)							
33a	Happy Days	Setback	2.2	3.3 (19)	Wd		Co	Aw,Tr,Du,Ma	Ds,Su,Sh,Tkw	Dr	E1E2E3a



E1 Awning (Aw), Trolley (Tr), Display unit (Du), Mats (Ma)
E2 Display stand (Ds), Standing unit (Su), Shelving unit (Sh), Takeaway window (Tkw)
E3 Door (Dr)

No.	Name	Physical Setting					Contents	Appropriation Elements Encountered			Encounter Pattern
		Setback			Const	Over head		E1	E2	E3	
		Shape	Depth	Width (Bldg)							
46	Skinholic	Setback-side	1.8	14	S	Ev	Co	Ma, Bn	Gm	Op	E1E2E3a



E1 Mats (Ma), Banner (Bn)
E2 Game machine (Gm)
E3 Opening (Op)

No.	Name	Physical Setting					Contents	Appropriation Elements Encountered			Encounter Pattern
		Setback			Const	Over head		E1	E2	E3	
		Shape	Depth	Width (Bldg)							
41b	Nail Party	Setback	1.3	4 (28)	RC	Pr	Fs	Ma	Cr, Su	Dr	E1E2E3a



E1 Mats (Ma)
E2 Clothing rail, Standing unit (Su)
E3 Door (Dr)

No.	Name	Physical Setting					Contents	Appropriation Elements Encountered			Encounter Pattern
		Setback			Const	Over head		E1	E2	E3	
		Shape	Depth	Width (Bldg)							
45	U&美	Setback	1.2	3.2 (10)	RC	x	Fs	Cr, Hf	Su	Op	E1E2E3a



E1 Clothing rail (Cr), Hanging frame (Hf)
E2 Standing unit (Su)
E3 Opening (Op)

No.	Name	Physical Setting					Contents	Appropriation Elements Encountered			Encounter Pattern
		Setback			Const	Over head		E1	E2	E3	
		Shape	Depth	Width (Bldg)							
17c	Unique Sense	Setback	5.5	3.3 (12)	RC		Fs	Aw,Bn	Tr	Op	E1E2E3a
<p>E1 Awning (Aw), Banner (Bn)</p> <p>E2 Trolley (Tr)</p> <p>E3 Opening (Op)</p>											

No.	Name	Physical Setting					Contents	Appropriation Elements Encountered			Encounter Pattern
		Setback			Const	Over head		E1	E2	E3	
		Shape	Depth	Width (Bldg)							
45	LaBelle	Cul-de-sac	0.8	3	Wd		Fs	Aw	Cr,Su	Dr	E1E2E3a
											
<p>E1 Awning (Aw)</p> <p>E2 Clothing rail (Cr), Standing unit (Su)</p> <p>E3 Door (Dr)</p>											

No.	Name	Physical Setting					Contents	Appropriation Elements Encountered			Encounter Pattern
		Setback			Const	Over head		E1	E2	E3	
		Shape	Depth	Width (Bldg)							
39	Korea shop	Setback	1.6	2.7 (7)	RC		Mr	Aw,Hf,Du	Ct,Su	Op	E1E2E3a
											
E1 Awning (Aw), Hanging frames (Hf), Display units (Du)											
E2 Trolley (Tr), Carton (Ct)											
E3 Opening (Op)											

No.	Name	Physical Setting					Contents	Appropriation Elements Encountered			Encounter Pattern
		Setback			Const	Over head		E1	E2	E3	
		Shape	Depth	Width (Bldg)							
39	Tina	Setback	10	2 (18)	RC	Pr	Fs	[Masters,ShopX,Ludia]	Hf	Op	E1E2E3b



E1 Shops [Masters, ShopX, Ludia]

E2 Hanging frame (Hf)

E3 Door (Dr)

No.	Name	Physical Setting					Contents	Appropriation Elements Encountered			Encounter Pattern
		Setback			Const	Over head		E1	E2	E3	
		Shape	Depth	Width (Bldg)							
42b	Fashion Cafe	Setback	10	2 (18)	RC	Pr	Fs	[Magic shop]	Hf	Op	E1E2E3b



E1 Shops [Masters, ShopX, Ludia]

E2 Hanging frame (Hf)

E3 Door (Dr)